

Further development and update of VECTO with new technologies

Specific contract No
340201/2020/835254/SER/CLIMA.C.4

By order of
EUROPEAN COMMISSION
DG CLIMA

Final Report

Martin Rexeis, Gérard Silberholz, Stefan Present (TUG)
Elias Blatsis, Nikolaos Kousias, Giorgos Mellios (Emisia)
Stefan Pofahl, Patrick Pertl (HyCentA)
Joan Carles Artigau, Vinayak Padmaji, Francesc Xavier Font
Alejandro García, Cecilia Saa, Eva Álvarez Pérez, Pablo Rodriguez (Idiada)

Report No. I-32/23/Rex Em Inst-20/07/18-670

Table of contents

Abbreviations	4
Executive Summary	7
1 Introduction.....	13
2 Task 1: Assess and possibly update of mission profiles and adjustment of reference emissions according to Regulation (EU) 2019/1242.....	14
2.1 Subtask 1.1: Gathering of representative road gradient data.....	15
2.2 Subtask 1.2: Analyse and possibly update VECTO mission profile(s).....	22
2.3 Subtask 1.3: Assess impact of the update on CO ₂ emissions	31
2.4 Subtask 1.4: Implementation of updated mission profile	33
3 Task 2: Hydrogen vehicles operated with fuel cell or internal combustion technologies.....	34
3.1 Subtask 2.1: Collection of feedback on the operation of VECTO for vehicles with electrified powertrains	34
3.2 Subtask 2.2: Fuel cell electric vehicles	35
3.3 Subtask 2.3: Internal Combustion Engines (partly) operated with hydrogen fuel	88
3.4 Hydrogen range (H ₂ R) and "Zero CO ₂ Emission Range" (ZCER)	92
3.5 Hydrogen storage capacity	95
3.6 Result matrix for hydrogen fuelled vehicles in VECTO	97
3.7 Implementation into VECTO	99
4 Task 3: Pantograph, catenary and connector systems for electrified vehicles.....	100
4.1 Subtask 3.1: Review of in-use charging technologies	101
4.2 VECTO calculation methods for vehicles with off-vehicle charging features	131
4.3 VECTO Implementation.....	148
5 Task 4: Platooning - Automated/Connected vehicles	150
5.1 Subtask 4.1: Review the state of the art of the technologies and influence of vehicle operation	150

5.2	Subtask 4.2: Environmental, economic, and social impacts	162
5.3	Subtask 4.3: Feasibility assessment	169
5.4	Subtask 4.4: Options for implementation in VECTO	172
6	Task 5: Open VECTO to user-defined control algorithms	174
6.1	Overview on the work performed.....	174
6.2	Feasibility analysis on coupling of real controllers with VECTO.....	175
6.3	Alternative approaches for controller consideration	179
6.4	Development of a technical demonstrator	180
7	Task 6: Technical support	188
8	Meetings	191
9	References	194

Abbreviations

AAUX	VECTO Advanced Auxiliary Model
AC	Alternating Current
ACC	Adaptive Cruise Control
ACD	Automatic Connection Device
ACEA	Association des Constructeurs Européens d'Automobiles
ACSF	Automatically Commanded Steering Function
ADAS	Advanced Driver Assistance Systems
AEBS/LDWS	Automatic Emergency Braking and Lane Departure Warning System
AMT	Automated Manual Transmission
APS	Aesthetic Power Supply
APT	Automatic Transmission
AV	Automated Vehicles
BEV	Battery Electric vehicle
BoP	Balance of Plant
BoPC	Balance of Plant Components
CACC	Cooperative Adaptive Cruise Control
CAV	Connected Automated Vehicles
CD	Charge Depleting
CEC	China Electricity Council
CFD	Computational Fluid Dynamics
CFCS	Composite Fuel Cell System
CI	Compression Ignition
CIF	Customer Information File
CLCCR	International Association of the Body and Trailer Building Industry
CoP	Conformity of Production
CS	Charge Sustaining
CST	Constant Speed Test (procedure to determine the air drag of HDV)
CSV	Comma Separated Values
DC	Direct Current
DEM	Digital Elevation Model
DG CLIMA	Directorate General for Climate Action
DG Grow	Directorate General for the Internal Market, Industry, Entrepreneurship & SMEs
DSM	Digital Surface Model
DSSAD/EDR	Data Storage System for Automated Vehicle and Event Data Recorder
EAFO	European Alternative Fuel Observatory
EffShift	"Efficiency Shift" algorithm developed for VECTO gear shift models
EM	Electric Motor

EMC	ElectroMagnetic Compatibility
EU	European Union
EVSE	Electric Vehicle Supply Equipment
FC	Fuel Cell
FCHV	Fuel Cell Hybrid Vehicle
FCS	Fuel Cell System
FCV	Fuel Cell Vehicle
FMI	Functional Mock-up Interface
FMU	Functional Mock-up Unit
FRAV	Functional Requirements for Automated and Autonomous Vehicles
FTE	Full Time Equivalent
GPS	Global Positioning System
GPX	GPS Exchange Format
H2R	Hydrogen Range (the distance which can be driven by a vehicle based on the usable amount of H2 fuel)
HDE	Heavy Duty Engine with type approval according to Regulation (EC) 595/2009
HDV	Heavy Duty Vehicle
HCDG	Heavy Duty CO2 Determination Group
HEV	Hybrid Electric Vehicle
HiL	Hardware in the Loop
HMI	Human Machine Interface
HPCVC	High Power Commercial Vehicle Charging
HTPEMFC	High Temperature Polymer Electrolyte Membrane Fuel Cell
IAP	Intelligent Access Policy
ICE	Internal Combustion engine
IEC	International Electro technical Commission
IEPC	Integrated Electrical Powertrain Component
ITS	Intelligent Transport Systems
JRC	Joint Research Centre
LDV	Light Duty Vehicle; here vehicles with type approval according to Regulation (EC) 715/2007. These are officially called "Light Passenger and Commercial vehicles"
MiL	Model in the Loop
MRF	Manufacturers Records File
MVC	Modular Vehicle Combinations
NG PI	Natural Gas Positive Ignition
OEM	Original Equipment Manufacturer
OVC	Off Vehicle Charging
PAF	Platooning Automated Function
PCC	Predictive Cruise Control

PEMFC		Polymer Electrolyte Membrane Fuel Cell
PHEV	Plug-In Hybrid Electric Vehicle (battery recharged from the grid also)
PIF	Primary vehicle information file
PP	Pilot Phase
PSF	Platoon Support Function
REX	Range Extender
RRC	Rolling Resistance Coefficient
SAE	Society of Automotive Engineers
SiL	Software in the Loop
SMT	Synchronised Manual Transmission
SOC	State of Charge
SOFC	Solid Oxide Fuel Cell
SRID	Spatial Reference Identifier
TCMV	Technical Committee for Motor Vehicles
TF	Task Force
TF-FCS	Task Force – Fuel Cess Systems
ToR	Terms of Reference
TPMLM	Technical Permissible Maximum Laden Mass
TTC	Time to Collision
TUG	Technical University Graz
UD	Urban Delivery
UITP	International Association of Public Transport
UN	United Nation
URL	Uniform Resource Locator
VCU	Vehicle Control Unit
VECTO	Vehicle Energy Consumption calculation TOol
VMAD	Validation Method for Automated Driving
VTP	Verification Testing Procedure
WAVE	Wireless Advanced Vehicle Electrification
WHTC	World Harmonized Transient Cycle
WLTC	Worldwide harmonized Light duty driving Test Cycle
WLTP	Worldwide harmonized Light vehicle emissions Test Procedure
WP	Work Package
WPT	Wireless Power Transfer
XML	Extensible Markup Language

Executive Summary

The current approach on the determination of CO₂ emissions and fuel consumption from HDV as laid down in Commission Regulation (EU) 2017/2400 and as implemented in the current version of the VECTO tool does not cover several vehicle technologies, which will play a relevant role in future HDV. The aim of this project was to update VECTO to be able to calculate CO₂ emissions, energy and fuel consumption for the most relevant of these technologies. Furthermore, a few existing elements in VECTO should be improved in order to reflect real world performance of HDV as representative as possible. The specific issues addressed in this project were:

1. Assess and possibly update of mission profiles and adjustment of reference emissions according to Regulation (EU) 2019/1242 (Task 1)
2. Hydrogen vehicles operated with fuel cell or internal combustion technologies (Task 2)
3. Pantograph, catenary and connector systems for electrified vehicles (Task 3)
4. Platooning - Automated/Connected vehicles (Task 4)
5. Open VECTO to user-defined control algorithms (Task 5)
6. Technical support (Task 6)

Task 1: Assess and possibly update of mission profiles and adjustment of reference emissions according to Regulation (EU) 2019/1242

A first step in this task was to collect data on road gradient profiles that are representative for European long-haul transport. The basis for these representative profiles were data on the 18 major long distance transport routes as identified in the Prograns project. In addition, a general method for calculating gradient data for a route based on various types of altitude data was developed. The aim was to validate the gradient data from the Prograns project and to create gradient data for new routes if needed. The methodology developed can be applied to existing routes (e.g. collected with GPS devices) or to user-designed routes (using the Google Maps route service). All tools and resources used are open source.

The next step was to analyse the current long haul mission profile used by VECTO and assess whether it needed to be updated. The analysis focused on the gradient profile of the cycle. For the comparison the following parameters were used:

1. Indicators of the gradient profile (e.g. slope distribution)
2. The wavelength content of the gradient profile
3. VECTO simulations to evaluate the impact of ADAS technology on reducing energy consumption.

The result of the analysis was that the gradient profile of the current long-haul needed to be updated as it showed a significantly lower wavelength content in certain frequency domains and therefore a lower impact of ADAS on the energy consumption of the vehicle.

To create a new gradient profile for the long-haul cycle, 200 candidate profiles with the cycle length of 100 km as specified for the VECTO simulations were generated from the wavelength distribution of the Prograns routes using an inverse Fourier transform. To select the most representative profile from these, a number of typical vehicles, including conventional, hybrid and battery electric trucks, were selected and simulated in VECTO. The technology benefit of each vehicle technology

compared to the conventional truck was analysed. Furthermore, some additional criteria regarding the altitude profile of the cycle were evaluated. Based on these two criteria (technology benefits and altitude profile criteria), the most suitable gradient profile was selected. For the investigated trucks, the updated long haul cycle results in approximately twice as high fuel consumption savings through PCC and also consistently higher technology advantages through hybridisation. As far as the fuel consumption of a conventional truck is concerned, the updated cycle is about 2 percent lower than the current long haul cycle. This analysis was presented to DG CLIMA and JRC and to stakeholders in March 2022. In these meetings it was decided to adopt the new long haul cycle and implement it in the next update of the official VECTO version (Version 3.3.11.2675 as published on the 29th of April 2022).

As a result of this mission profile update and other VECTO model updates carried out with the above mentioned release, an update of the reference CO₂ emissions relevant for the HDV CO₂ standards became necessary. In this task, the project team supported the Commission in the preparation of the adjustment as required by Regulation (EU) 2019/1242.

Task 2: Hydrogen vehicles operated with fuel cell or internal combustion technologies

Target of task 2 was to integrate propulsion technologies based on hydrogen fuel into VECTO and into the component testing procedures as prescribed in Regulation (EU) 2017/2400. Hydrogen fuelled vehicles can either burn hydrogen solely or in combination with other fuels in an internal combustion engine or use fuel-cell technology to generate electric energy to drive a fully electric vehicle.

Fuel cell vehicles

Starting with an analysis of current HDV fuel cell technologies as well as existing standards on testing procedures and fuel cell development, a component procedure for fuel cell systems (FCS) was developed in close cooperation with stakeholder representatives in the "task force fuel cell systems" (TF-FCS). The test procedure consists of a sequence of steady-state operating points, which are run through in an ascending and then descending load sequence, and during which the system's electrical output and hydrogen consumption are measured. A characteristic curve is then determined from this measurement data as input for VECTO. Investigations in the TF-FCS have shown that the transient operating states of the FCS can be determined with high accuracy using this steady-state data. The test procedure was prepared as an extension of the existing Annex Xb in MS Word format with all further elements required according to Regulation (EU) 2017/2400 (e.g. information document, standard values, family concepts, conformity of production).

In parallel, based on an analysis of possible fuel cell vehicle powertrain configurations, a simulation approach for fuel cell vehicles was developed in VECTO. This approach is based on the FCS component model using the characteristic curve described above, the existing xEV component model in VECTO (e.g. for batteries) and the following additional fuel cell vehicle specific elements:

- Representation of the possible operating modes of the vehicle analogous to HEV by means of a "charge sustaining mode" and a "charge depleting mode" (the latter only if the vehicle can be charged externally with electrical energy)
- A generic operating strategy that distributes the electrical energy required by the vehicle between the FCS (or multiple FCSs, if present) and the battery. The aim of the algorithm is to maximise the phlegmatisation of the operation of the FCS in order to minimise ageing and achieve the highest possible efficiency.

- A generic model to represent the energy consumption for cooling the FCS

Vehicles driven with internal combustion engines fuelled with hydrogen fuel

In the first phase of the project, a questionnaire was sent to industry to analyse the situation regarding hydrogen-fuelled internal combustion engines. The main findings of this survey were that ICE powered by pure hydrogen is definitely a relevant propulsion technology for the expected period of application of the third amendment. No major issues were identified with regard to CO₂ certification for VECTO, but as a prerequisite the coverage of H₂ ICE technologies in UN Regulation 49 for pollutant type approval needs to be covered. Later in the project, several stakeholders also requested the H₂ ICE dual fuel technology (diesel pilot injection with compression ignition combustion).

In a next step, the necessary revisions and extensions to cover the above-mentioned H₂ ICE technologies in the component testing procedure as laid down Annex V of Regulation (EU) 2017/2400 were elaborated. The most important specific elements are:

- Fuel specifications of a hydrogen reference fuel
- Requirements on accuracy of mass flow measurement for hydrogen
- Implications on and necessary changes to the existing EURO VI emission type approval for HDV based on Regulation (EC) No 595/2009 and its amendments

Since UN Regulation R49, which is currently being amended (period 2023/24) to include H₂ ICE technologies, is required as stable basis for several references to be implemented into Annex V of Regulation (EU) 2017/2400, the concrete drafting of Annex V was therefore not possible during the project duration.

As far as the simulation of H₂ ICE technology at vehicle level in VECTO is concerned, the modelling approaches for conventional engines can essentially be used. However, there are some specifics in the simulations that apply to all vehicles powered by H₂ (including fuel cell vehicles) and are described below.

Overarching issues for hydrogen vehicles in VECTO and Regulation (EU) 2017/2400

In addition, it was necessary to work out some methods that are generally required for hydrogen vehicles in VECTO and thus in Regulation (EU) 2017/2400. These are

- Formulas to calculate the "hydrogen range" and the "zero CO₂ emission range".
- Rules for declaring the usable hydrogen storage capacity on a vehicle
- The matrix of results to be provided by VECTO in the official results of the tool (i.e. which quantities such as fuel consumption or ranges are reported for which vehicle operating modes).

All the approaches described above for modelling hydrogen powered vehicles have been implemented in a development version of the VECTO tool and made available to the Commission and stakeholders for testing.

Task 3: Pantograph, catenary and connector systems for electrified vehicles

Task 3 covered the relevant VECTO topics around in-use electric charging technologies as currently already established or under development for HDV applications. As a starting point for the work, a comprehensive technological review and assessment of the current and future charging systems

applicable for various heavy-duty applications has been elaborated. Research and industrial stakeholders, literature and internet have been the sources of information for this task. In addition, the review of in-use charging technologies also considers a regulatory perspective in order to identify which technologies are aligned with the current regulatory framework.

In a next step, methods were developed to model the Regulation (EU) 2017/2400 relevant characteristics of the different charging technologies in VECTO. A crucial point in development of the approach was the discussion with Commission and stakeholders on where the reference point for the balancing of the electric energy consumption as calculated by VECTO should be. This definition is central to whether and how the influence of the different charging technologies is to be modelled. The conclusion from the discussions was that the most practical and reasonable solution is to choose the balancing point at “battery terminals”, i.e. not covering losses in the charging infrastructure. This basic approach was also adopted for the work on the VECTO methods for the 2nd amendment of Regulation (EU) 2017/2400, which was not yet completed at that time.

For the consideration of in-motion charging technologies, another fundamental question to be clarified was whether driving with “direct feed” electrical energy supply should be simulated as a separate operating mode in VECTO (in addition to the “charge depleting” mode and, in the case of HEV, also the “charge sustaining” mode as already implemented in the 2nd amendment VECTO version). Here, a simple and robust method was found that allows the calculations for charge depleting mode to be extended to include the in-motion charging feature by means of a special post processing. With this approach, unnecessarily detailed definitions are avoided (e.g. on which specific sections of a mission profile overhead lines are available). Furthermore, the simulation time of VECTO does not increase compared to vehicles without the in-motion charging feature.

The third fundamental question to be clarified was whether and how the “electric ranges” as calculated by VECTO are influenced by the presence of in-motion charging features. It was found that also in the case of in-motion charging, it is meaningful to specify as electric range the distance that can be driven “from the battery”, i.e. without using the charging infrastructure. It is this information which is essential for the vehicle user to assess the performance of the vehicle. Furthermore, for OVC hybrids powered by ICEs with carbon containing fuel, the amount of electrical energy charged during the mission is relevant to calculate the mission average CO₂ emissions. For this, generic assumptions on charging patterns by technology needed to be made in VECTO.

The in-motion charging technologies “over-head catenary” and “overhead trolley” were identified as the most relevant additional technologies to be considered by the 3rd amendment. As an outcome of the project concrete proposals for the generic parameters in VECTO and the necessary extensions in the Annexes of Regulation (EU) 2017/2400 are available.

All additional features of VECTO proposed for the 3rd amendment were incorporated into a development version of the tool and made available to the Commission and stakeholders for testing.

Task 4: Platooning - Automated/Connected vehicles

Advanced control and driver assistance systems enable a number of technologies that could potentially contribute to the reduction of energy consumption and CO₂ emissions in heavy duty vehicles. The scope of this task was to investigate the most prominent technologies currently proposed by different stakeholders and to identify viable pathways for their future integration into VECTO.

Adaptive cruise control (ACC) and Platooning were identified as the basic relevant technologies in this context. ACC is a semi-automatic driving function that maintains a time-dependent distance to

the vehicle in front, but does not offer any considerable advantages in terms of fuel economy. In Platooning, HDV drive in a linked convoy under the command of a lead vehicle, which brings aerodynamic advantages to all vehicles following behind and reduces fuel consumption and emissions. Implementing Platooning requires vehicles to communicate with one another and, depending on the level of automation, also with the road infrastructure. Platooning can be divided into two strategies: Platooning Support Function (PSF) and Platooning Automated Function (PAF). PSF has fewer aerodynamic advantages due to the greater distances between vehicles, while PAF offers a higher degree of automation and potential for fuel savings. Due to the current maturity of the technology and the necessary regulatory framework, both for vehicle type approval and national road traffic regulations, only PSF technology is considered a candidate for market entry in the next few years. General limitations of Platooning include restricted implementation on road sections with frequent access and exit-ramps or intersections, roads with high traffic volumes, weather conditions and communication issues.

The environmental impact of platooning technology, especially on fuel consumption and CO₂ emissions, has been studied in several European and national projects in recent years. A wide range of possible savings was found, from 0.5 to 10%, depending on the conditions of the tests, such as the minimum distance between the vehicles, the difference in the average speed of the platoons compared to the reference vehicles and whether the driving tests were carried out under laboratory conditions on a test track or in test operation on real roads.

Regarding the implementation into VECTO, two different modelling approaches were drafted in this project. However, as there is no data available on the actual operating conditions on the road, assumptions would have to be made in the modelling in VECTO. These relevant operating conditions are e.g. the share of motorway kilometres where a vehicle equipped with PSF is actually in the platoon (with limiting factors: other vehicles with such technology on the road, share of suitable road sections and traffic intensity, etc.) and the average distance to the vehicle in front in the platoon (depending e.g. on payload and weather conditions). The following options are proposed by the project team for the treatment of platooning for the 3rd amendment of Regulation (EU) 2017/2400:

- 1) No consideration. Review the issue at a later stage, when robust data on the technology in real-world operation is available. Then, the methodologies developed in this project could be adopted and implemented based on real operational data.
- 2) If there are ambitions from the Commission and stakeholders to include a bonus for this technology from the start: Implement platooning in the 'simple' option outlined in this work, keeping the assumptions as simple as possible.

Task 5: Open VECTO to user-defined control algorithms

The objective of this task was to investigate the feasibility of an updated VECTO version, capable of handling software- and hardware-in-the-loop (SIL & HIL) simulations.

Particular subject of the analysis was, whether the control algorithms as actually used in vehicles on the road could be coupled to the VECTO software in the context of the official application following Regulation (EU) 2017/2400. The conclusion of the analysis was that such a coupling is for many reasons neither technical feasible nor even desirable. The latter is mainly due to the fundamental lack of transparency associated with this, the high costs for the Commission and manufacturers and the associated systematic discrimination against small manufacturers.

In the follow-up to the feasibility analysis, further considerations were made on alternative approaches other than a 1-to-1 integration with which controller features can be taken into account in Regulation (EU) 2017/2400. These approaches are solutions that are already - at least partially - applied in Regulation, e.g. the possibility to declare the extent of electric boosting provided in a HEV.

In parallel to the activities described above, work on the development of a technical demonstrator for linking the official VECTO version with "external" control algorithms was performed. In this work, two strategies implemented in Matlab/Simulink (Case 1: An AMT gear shift strategy previously used in VECTO, Case 2: A highly simplified hybrid control strategy provided by ACEA as an example) were coupled with VECTO using the FMI/FMU methods. The two demonstration cases show that it is at least in principle technically feasible to use strategies implemented in an external module. However, no generally valid technical feasibility can be derived from this work.

Task 6: Technical support

Task 6 was designed to address various aspects related to the VECTO tool and adjacent software under the contract. The scope included bug fixing, ensuring smooth functionality of VECTO, and providing technical support for updating or developing tool modules if required for certification purposes. The work process was organized using the ticket system in CITnet JIRA and later in GitLab / code.europa.eu after IT system migration.

The breakdown of work based on the number of days and count of tickets revealed that the largest portion of the working time (about 45%) was spent on the on-demand implementation of new content and improvements. Bug fixes for existing features accounted for just under 30% of the working time. User support included the highest number of tickets but consumed a relatively smaller amount of working time.

1 Introduction

The current approach on the determination of CO₂ emissions and fuel consumption from HDV as laid down in Commission Regulation (EU) 2017/2400 and as implemented in the current version of the VECTO tool does not cover several vehicle technologies, which will play a relevant role in future HDV. The aim of this project was to update VECTO to be able to calculate CO₂ emissions, energy and fuel consumption for the most relevant of these technologies. Furthermore a few existing elements in VECTO should be improved in order to reflect real world performance of HDV as representative as possible. The specific issues addressed in this project were:

1. Assess and possibly update of mission profiles and adjustment of reference emissions according to Regulation (EU) 2019/1242 (Task 1)
2. Hydrogen vehicles operated with fuel cell or internal combustion technologies (Task 2)
3. Pantograph, catenary and connector systems for electrified vehicles (Task 3)
4. Platooning - Automated/Connected vehicles (Task 4)
5. Open VECTO to user-defined control algorithms (Task 5)
6. Technical support (Task 6)

This final report to this project is structured as follows:

Chapter 2 to chapter 7 document the results of the tasks mentioned above.

Chapter 8 lists the meetings with stakeholders as held during the project.

Chapter 9 contains the list of references.

Furthermore, the documents listed in Table 1 are supplementary parts of the final report;

Table 1: Supplementary documents to the final report

Filename	Content
Task2_FCS_Annex10b_WorkingDoc.docx	Draft amendments to Annex Xb for the certification of Fuel Cell Systems (FCS)
Task2_FCS_Annex10b_ListFinalFeedback.docx	Final feedback list of the task force fuel cell systems (TF_FCS) on the above document
Task2_H2_ICE_Questionnaire.docx	Questionnaire on H2 combustion engines as distributed to stakeholders in the first phase of the project
Task3_Masterexcel_OVC_IMC.xlsx	Documentation of all VECTO post-processing routines for modelling vehicles with off-vehicle charging features ("plug-in") as well as vehicles with in-motion charging features as proposed for the 3rd Amendment.
Task6_ListTickets.xlsx	List of tickets / issues that were processed within the scope of Task 6.

2 Task 1: Assess and possibly update of mission profiles and adjustment of reference emissions according to Regulation (EU) 2019/1242

VECTO uses so called “mission profiles” to simulate the energy and fuel consumption as well as CO₂ emissions for typical HDV application types. Each mission profile is defined by a course of target speed and road gradient over distance. This data essentially influences the absolute CO₂ levels predicted by VECTO for the European HDV fleet but also the predicted ranking between different vehicle technologies in terms of CO₂ emissions.

The development of the current mission profiles has been driven by ACEA (lorry cycles) and coordinated efforts of ACEA as well as ZF and VOITH with support and review from the Commissions consultants see [1] and [2]). The latest updates on mission profiles have been introduced during the LOT4 project and were implemented into the VECTO tool in 2017 before the official CO₂ determination for certain HDV groups has become mandatory.

Analysis as presented by ACEA in the VECTO board meetings in 2019 and 2020 indicated that the gradient profile of the mission profile for long haul as implemented so far appears to under-represent the level of hilliness for European conditions. It was stated, that – in the elaboration of the cycle by the ACEA consultant LIME - only the slope amplitudes were considered but not the wavelengths. Using this current long haul cycle VECTO would underestimate the impacts of any vehicle technology which buffers potential energy with certain energy storage restrictions, e.g. like Predictive Cruise Control (PCC) as well as any form of hybrid propulsion which is able to recuperate brake energy.

In task 1 of this project the representativeness of the gradient data of the current long-haul cycle was to be analysed, if necessary updated and implemented into the VECTO tool. Furthermore, if applicable, the impact of the update on the fuel efficiency gains from ADAS systems shall be evaluated and the Commission should be supported in the elaboration of adjustment factors to the reference CO₂ emissions as required by Regulation (EU) 2019/1242.

Task 1 is divided into four subtasks:

- Subtask 1.1: Gathering of representative road gradient data
- Subtask 1.2: Analyse and possibly update VECTO mission profile(s)
- Subtask 1.3: Assess impact of the update on CO₂ emissions
- Subtask 1.4: Implementation of updated mission profile(s)

2.1 Subtask 1.1: Gathering of representative road gradient data

2.1.1 Purpose of the task

The goal of this subtask was to gather data on road gradient profiles representative for European long-haul transport. The starting point for such representative profiles, was the examined routes by the ProgTrans project ([3], the report was shared with the Commission). Additionally, a methodology was developed to calculate gradient data for a route. The scope of the methodology was to validate the gradient data from the ProgTrans project and to have the ability to create gradient data for new routes, if needed. The developed methodology can be applied to existing routes (acquired by GPS devices) or to user-designed routes (using the Google Maps' Directions Service). All the tools and resources used are open-source.

An overview of the process is illustrated in Figure 1 below.

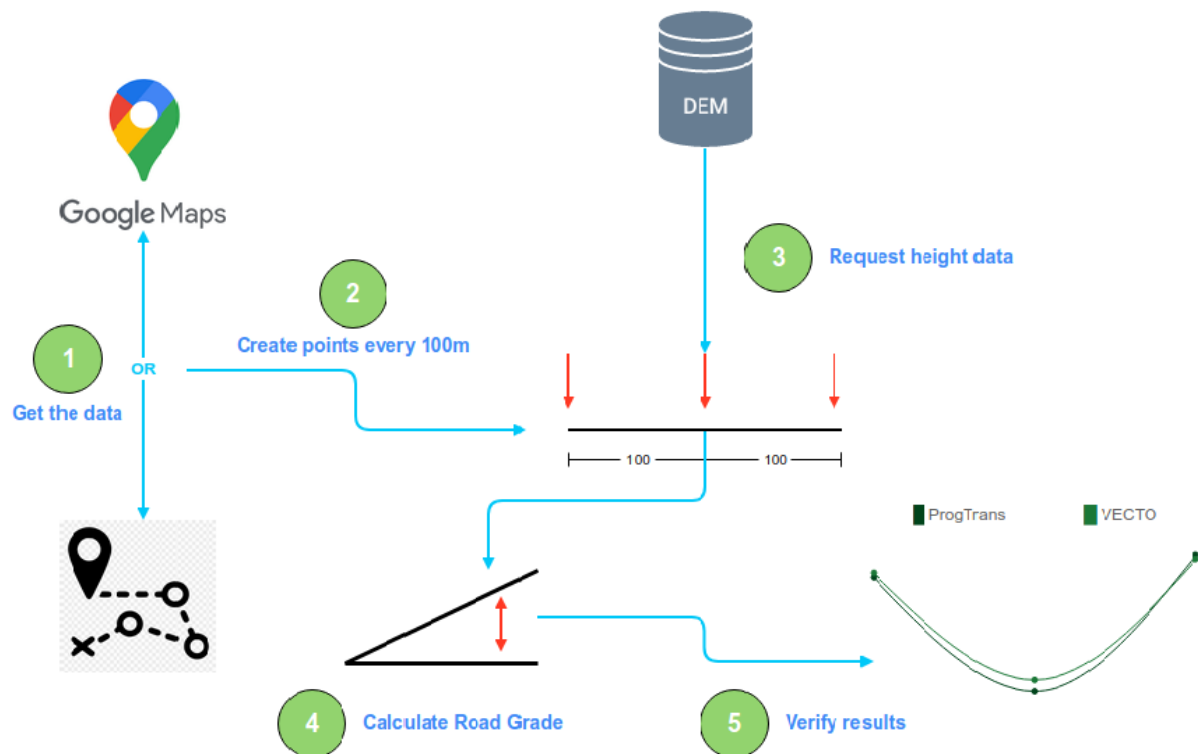

Figure 1: Overview of the process that was followed for altitude calculation and evaluation

2.1.2 Terminology

Here is a brief description of the terms that are used throughout this chapter:

DEM: The Digital Elevation Model is a representation of the bare ground (bare earth) topographic surface of the Earth excluding trees, buildings, and any other surface objects.

DSM: The Digital Surface Model is an elevation model that captures both the environment's natural and artificial features. It includes the tops of buildings, trees, powerlines, and any other objects.

SRID: The Spatial Reference Identifier (SRID) is a unique identifier associated with a specific coordinate system, tolerance, and resolution. In this task we used three different SRIDs: EPSG:4326, EPSG:3035 and EPSG:4258.

EPSG:4326 (or WGS84): The World Geodetic System 1984 is the SRID used by the GPS systems. It uses degrees as unit.

EPSG:3035 (or ETRS89-extended / LAEA Europe): Is a spatial reference system using meters as unit. It covers the whole Europe with 1.0m accuracy. It is used when we need accuracy in distance-based calculations (e.g. when we create the 100m segments over a route).

EPSG:4258: It covers the same area as EPSG:3035 but it uses degrees as unit. This is the SRID of the DEMs from Eurostat.

GPX: The GPS Exchange Format is an XML schema designed for the exchange of information between GPS devices and software applications.

GeoTIFF: A file format that embeds geospatial metadata into image files such as aerial photography, satellite imagery, and digitized maps so that they can be used in GIS applications.

2.1.3 Tools

The software tools and resources used in this task, are the following:

qGis software: An open-source GIS software for the visualization and manipulation of geospatial data. It can handle a variety of geospatial formats (csv, GeoTIFF, GeoJSON, Shapefiles, spatial data from databases, etc.) and it also provides a powerful Processing Toolbox for geospatial calculations and transformations.

PostgreSQL/PostGIS: A relational database management system with an add-on library for executing geospatial queries.

Google Maps' Direction Service: An online tool by Google for finding the shortest route between two locations.

MapsToGPX (<https://mapstogpx.com/>): An online tool that converts a Google Maps route to GPX file.

EU-DEM: The **Digital Elevation Models from Eurostat** containing the elevation data for all European countries (<https://ec.europa.eu/eurostat/web/gisco/geodata/reference-data/elevation/eu-dem>). The EU-DEM is actually a DSM representing the first surface that is captured by the sensors. The dataset was produced by the Copernicus program, which is managed by the European Commission's Directorate-General for Enterprise and Industry.

2.1.4 Routes

This methodology can be applied both on existing routes tracked by GPS devices, and on routes designed using the Google Maps' Direction Service.

2.1.4.1 From GPS

The GPS route we used was available in CSV format. We imported the route into the qGis software (Menu -> Layer -> Add delimited text layer) and we came up with a new Point layer containing all the route's waypoints.

Next, we combined the Points to create a continuous line (Linestring geometry). To achieve this we used the tool "Point to path" from qGis' Processing Toolbox. We also used the "Reproject Layer" tool for transforming the GPS co-ordinates from SRID EPSG:4326 to EPSG:3035, as it is a spatial referencing system which provides more accuracy when we deal with distances.

The final output of this step is a new layer with the route as a continuous line.

2.1.4.2 From Google Maps

In case GPS data was not available, we used the Directions Service from Google Maps to design the desired route, e.g. from Milan to Pescara, see Figure 2.

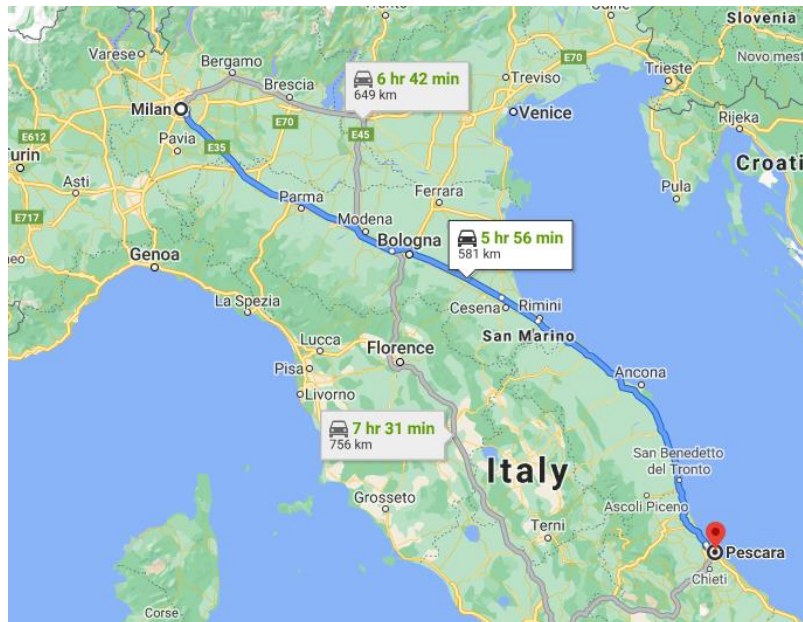
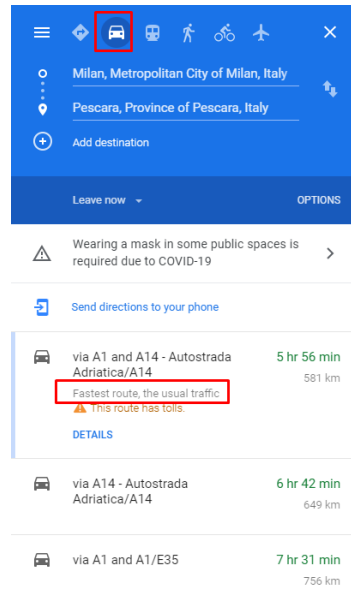

Figure 2: Example of the Google Maps Directions Service for a route from Milan to Pescara

Then we copied the URL provided by the Directions Service, and used it in the Mapstogpx.com online tool.

The tool created a GPX file containing the route we had just designed. Afterwards, we imported the file into the qGis software and converted its spatial referencing system from EPSG:4326 to EPSG:3035, exactly as we did with the GPS file.

2.1.5 Slice the route into 100-meter segments

The final outcome of both previous steps is the same: a layer with a continuous line representing the route. The next step is to create discrete points at 100 meter intervals. To do so, we used the tool "Points along geometry" from the processing toolbox, see Figure 3. This tool accepts a line

layer as input and a distance (in our case 100 meters) and produces a new layer with Point geometries along the initial line which are exactly 100 meters apart. Because this is a distance-based calculation, it is imperative that the input layer is in a meter-based SRID, e.g. the EPSG:3035.

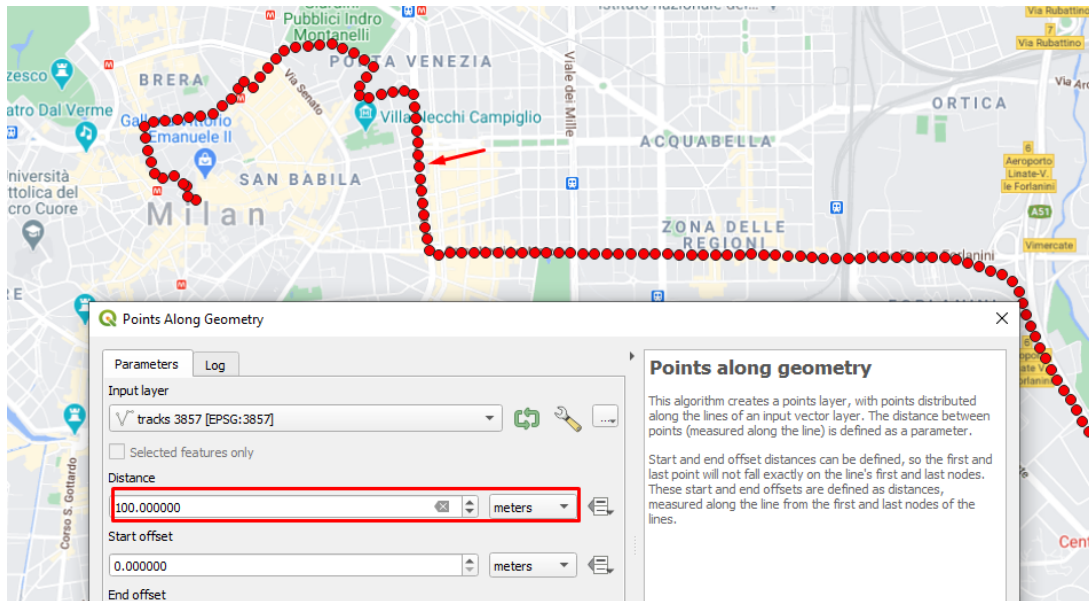

Figure 3: Example of the new layer with discrete points at 100 meter intervals for the Milan to Pescara route. The outcome of this step is a new layer with points every 100 meters along the route.

2.1.6 Elevation

The next step is to retrieve the elevation of every point in the points layer. Typically, the data is available from the GPS recordings and included in the respective csv files. In this case we can skip this step. When the elevation is missing from the csv files, it is derived from Eurostat’s Digital Elevation Model using the approach described below.

Because Eurostat provides the EU-DEM as 1 by 1 degree tiles, we first combined them into one GeoTIFF image covering the whole of Europe. Also, the EU-DEM tiles are in EPSG:4258 projection, while the points layer is in EPSG:3035. Therefore, we need to reproject the points to match the EU-DEM’s projection.

As we did in the previous step, we used the “Reproject Layer” tool from the Processing Toolbox (Figure 4):

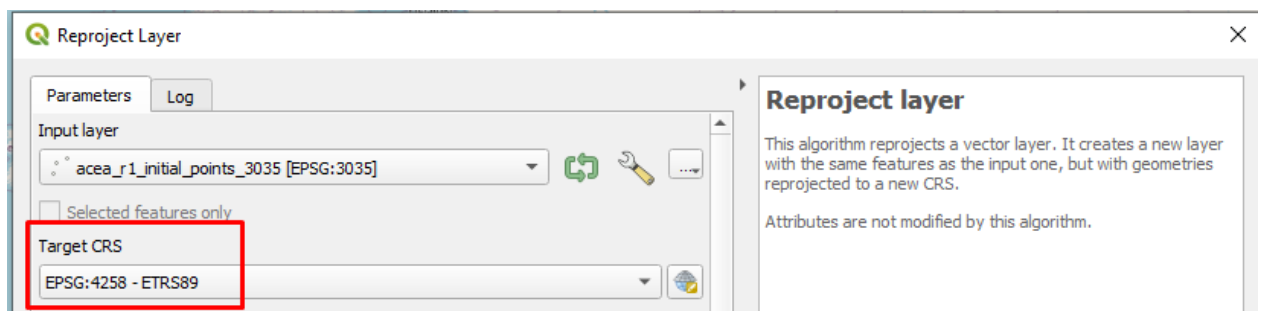

Figure 4: Reproject the altitude data to match with the projection format of the discrete points at 100 m interval

Then using the tool “Sample raster values” we retrieved the elevation of each point (Figure 5).

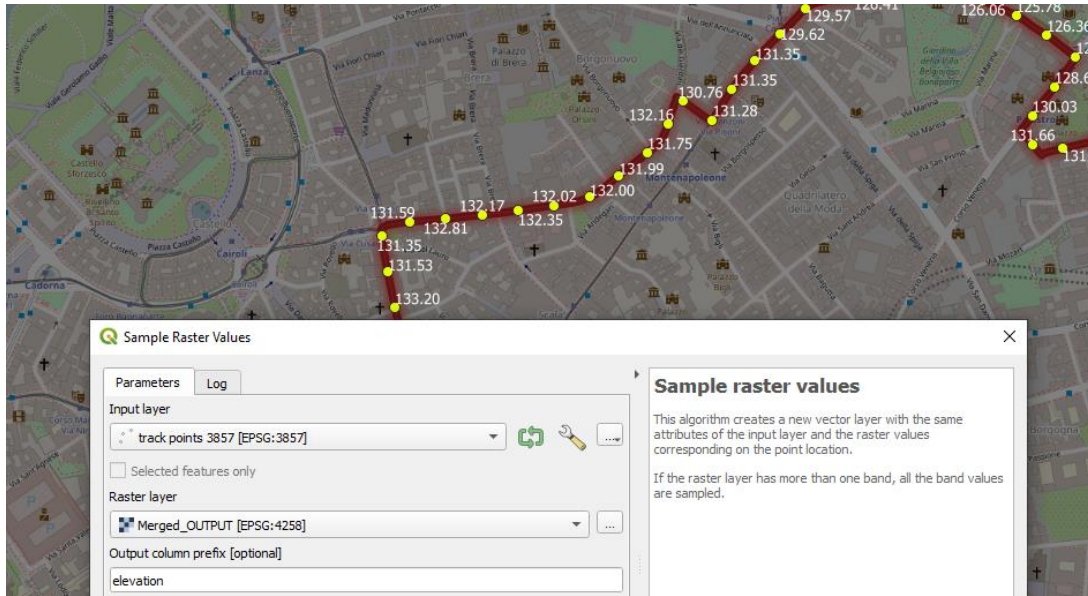

Figure 5: Extract altitude data for the discrete points of the Milan to Pescara route based on the GeoTIFF image data

In this tool we used the points layer as “Input Layer” and the combined GeoTIFF image as “Raster Layer”.

The outcome of this step is the addition of one extra column (named “elevation”) in the points layer, containing the elevation of each point.

Then we imported this new layer into a PostgreSQL database.

2.1.7 Calculate Road Gradient

To calculate the road gradient for each of the 100 meters segments, we computed the difference in height between two consecutive points, by subtracting the elevation of any given point from the elevation of the previous point. The gradient is then computed from the elevation difference of the route segment and the distance driven, which by design is 100 meters (Figure 6).

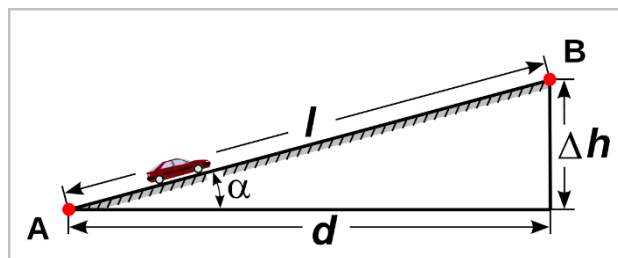

Figure 6: Method for grade calculation

2.1.8 Results

The methodology described above has been applied to the 18 major long distance transport routes in Europe, as they have been identified by ACEA (performed by Prograns in 2014):

1. Hamburg – Recklinghausen
2. Hamburg – Wuerzburg
3. Koln – Wuerzburg
4. Burgos – Saarbrucken
5. Barcelona – Genova
6. Genova – Karlsruhe
7. Modena – Munich
8. Recklinghausen – Warsaw
9. Giessen – Krakow
10. Karlsruhe – Budapest
11. Berlin – Munich
12. Warsaw – Katowice
13. Rome – Genova
14. Milano – Pescara
15. Milano – Trieste
16. Dover – Swansea
17. Exeter – Carlisle
18. Stockholm – Hamburg

The csv files from ACEA contain the road gradient (and not the elevation data) between the route points. Also, the sampling rate is arbitrary (in contrast to the steady 100m distance we used in our methodology).

Using the distance and the road gradient we calculated the relative differences in elevation for all the points within each route.

A side-by-side comparison of the charts derived from our methodology and the charts derived from ACEA data, considering the difference in sampling rate between the two datasets, shows that the elevation data are consistent in the two datasets. Thus, there are no major problems with the ProgTrans data, and they can be used as representative gradient profiles. The next image shows the charts for the route from Karlsruhe to Budapest (the top chart is based on elevation data from Eurostat and the bottom chart is based on ACEA's csv file).

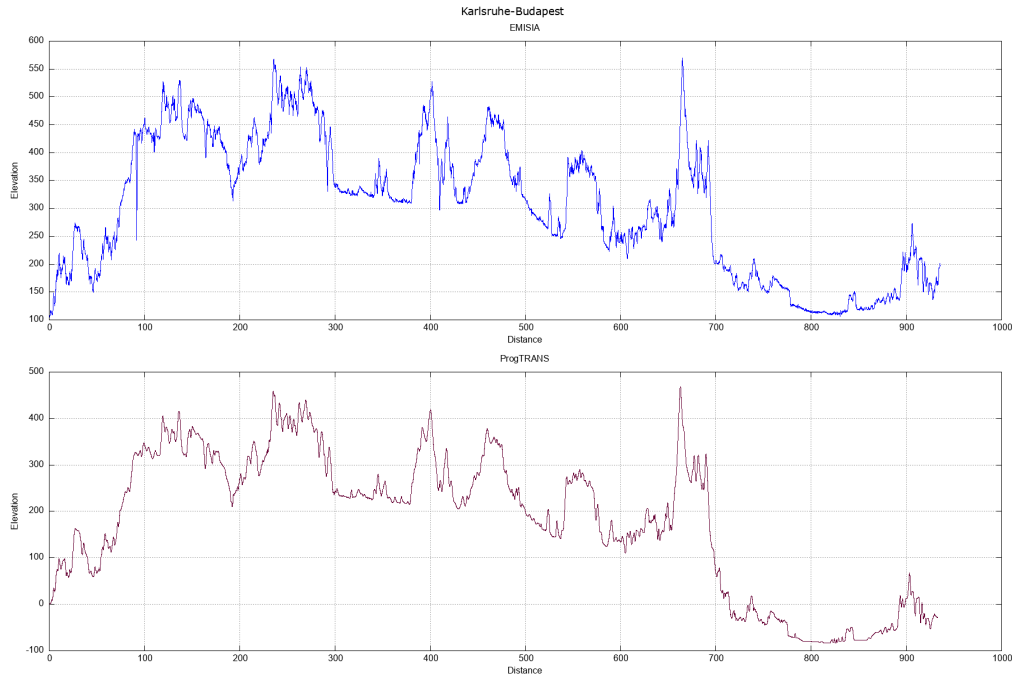

Figure 7: Altitude profile of the Karlsruhe to Budapest route based a) on the Prograns data and b) on the method present in this subtask

2.2 Subtask 1.2: Analyse and possibly update VECTO mission profile(s)

2.2.1 Purpose of the task

The purpose of this task was to analyse the current long-haul mission profile that VECTO uses and evaluate if it needs to be updated. The analysis focuses only on the gradient profile of the cycle. The 18 major long distance transport routes that were identified during the Prograns project, are used as a reference set of real European long-haul routes.

For the comparison we used:

1. indicators of the gradient profile
2. the wavelength content of the slope profile and
3. VECTO simulations to evaluate the effect of ADAS technology on reducing energy consumption

2.2.2 Comparison

2.2.2.1 Indicators

Three main indicators were used for the analysis. These are the positive elevation gain of the route, the distribution of the gradient profile and the variance of the gradient profile. The main results of the analysis are shown in Table 2 and Figure 8.

Table 2: Indicators of the current mission profile and the typical routes

Indicator	Current Long-Haul	Min of typical routes	Average of typical routes	Max of typical routes
Positive Elevation Gain	470	288	751	1581
Variance of grade	2.64	1.86	43.0	345.0

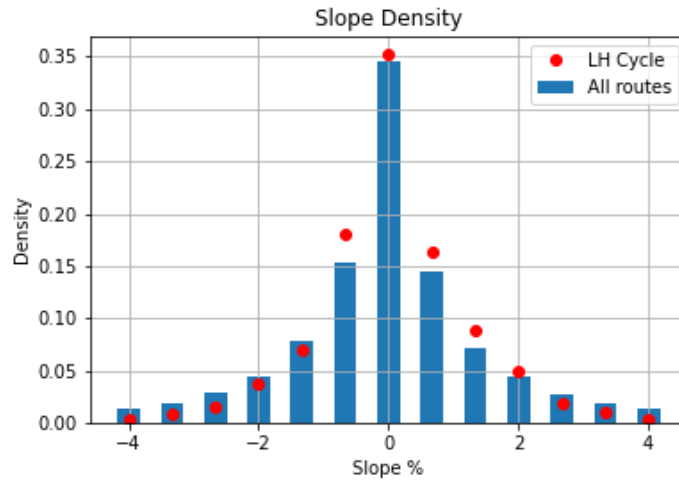

Figure 8: Slope distribution of the typical routes (blue bars) and the current long-haul mission profile (red dots)

The results show that the current long haul has slightly more sections with very small slope (1 % or less) and less steep sections (more than 3 %). Also, the positive elevation gain, and variance are significantly lower compared to the average of the typical routes.

2.2.2.2 Slope wavelength

A wavelength analysis was performed on the slope of the current long haul and the typical routes. To achieve that, a Fourier transform of the slope versus distance curve is calculated for each route. In Figure 9 the wavelength content of the current long haul and the average of all typical routes are shown.

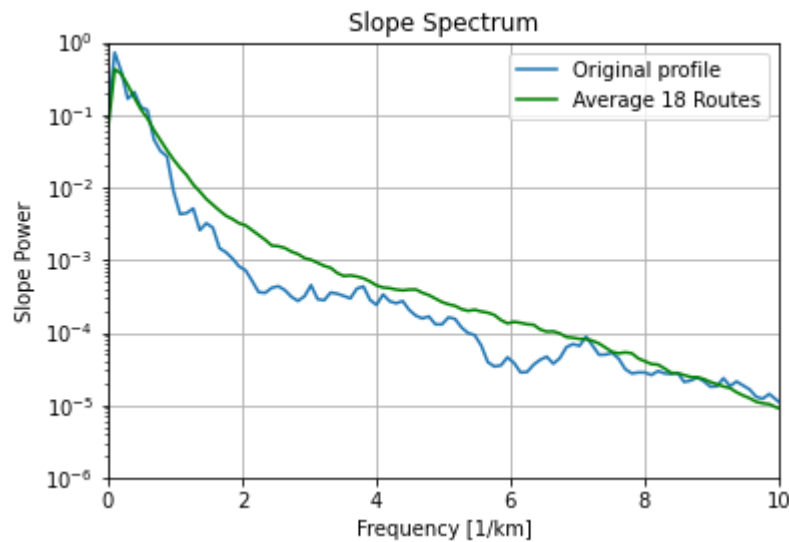

Figure 9: Wavelength content of the current long-haul mission profile (blue line) and of the average typical routes (orange line)

Both curves show a decrease of intensity for larger distances which is expected. However, there are two regions, one around 1/2 km and a second one around 1/6 km, where the current long haul has significantly lower amplitude compared to the average of the typical routes.

2.2.2.3 ADAS technology

To compare the effect of ADAS technology, it was necessary to create new routes with the same velocity profile as the current long-haul but with slope characteristics similar to the real routes. An algorithm as proposed by ACEA based on an inverse Fourier transform was used to create the new routes. The generated cycles, which are limited to a length of 100 kilometers as intended in VECTO for reasons of computing time, cannot perfectly match the given spectrum and contain a certain variation in the properties. Thus, to guarantee the representativeness of the generated routes, we created many routes and performed a statistical analysis.

Generation of new routes

The generation of new routes is based primarily on the wavelength analysis that was performed in the previous step. The average wavelength content of the typical routes was used to create a new profile. By randomly varying the phase of each wavelength component an infinite number of new altitude profiles can be generated. In the algorithm it is furthermore implemented that the small

"mountain" in current LH cycle is added to the generated profile at kilometre 35 into the cycle. Such mountains cannot be reproduced by the inverse Fourier transformation algorithm alone.

The altitude profile of an example route is presented in Figure 10a along with the current long-haul mission profile. The wavelength content of the two routes is shown in Figure 10b. Two hundred such routes were generated and used to evaluate the effect of ADAS technology.

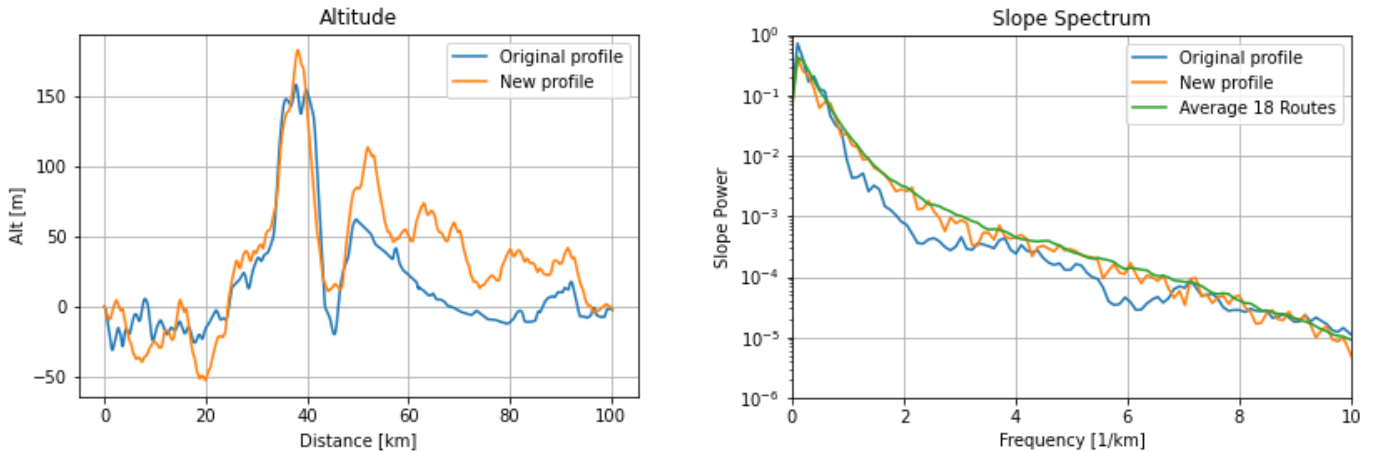

Figure 10: a) Altitude profile of the current long-haul mission profile and of an example generated route, b) wavelength content of the current long-haul mission profile, the average typical routes and the new generated route

Statistical analysis

The two hundred cycles that were generated were run in VECTO with a conventional group 5 tractor with and without ADAS¹. The distribution of the energy consumption is shown in Figure 11a. The average consumption of the new cycles compared to the current long-haul cycle is 0.28 % smaller. The benefit of the ADAS technology is shown in Figure 11b. The average benefit of the new cycles is 1.91 %. The current long-haul mission profile has a benefit of 1.10 % which is close to the lower end of the distribution.

¹ Details on the vehicle configurations are provided in section 2.2.3.1 below.

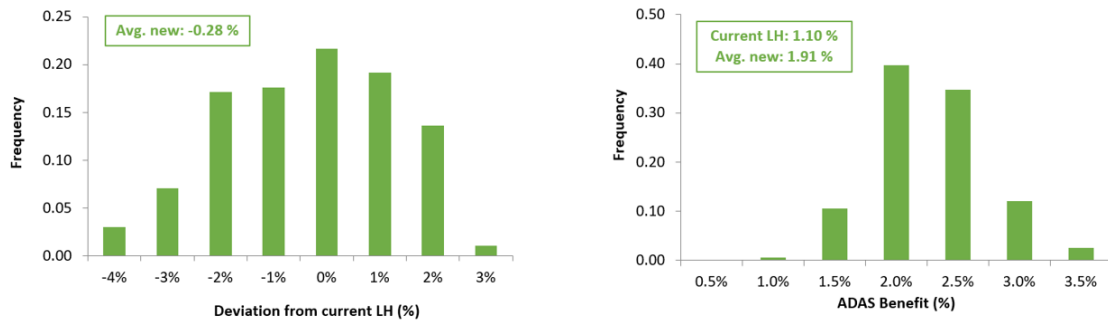

Figure 11: a) Distribution of the consumption of the new generated routes compared to the current long-haul mission profile, b) Distribution of the ADAS technology benefit for the new generated routes

We deduce that the energy consumption of the conventional vehicle is essentially the same. However, the benefit of the ADAS technology for the new routes is significantly larger.

2.2.2.4 Analysis outcome

The results of all three approaches show that the current long-haul needs to be updated. The selection of a new profile will be based on the results of the VECTO simulations.

2.2.3 Long-haul update

In order to update the long-haul profile, the following process was used. A number of typical vehicles including conventional, hybrid and battery-electric trucks were selected and simulated in VECTO. The two hundred cycles that were used in the ADAS technology comparison were run for each vehicle. The technology benefits of each truck compared to the conventional group 5 tractor without ADAS was calculated. Also, some additional criteria regarding the altitude profile of the cycle were evaluated. Based on these two types of criteria (consumption and altitude) the most suitable cycle was selected.

2.2.3.1 Simulated Vehicles

The generated cycles were simulated in VECTO in order to accurately evaluate the effect of different technologies. Group 5 trucks were selected for the analysis, since they perform most long-haul trips in Europe compared to other truck classes. The typical vehicles used for the analysis are shown in Table 3.

Table 3: Specifications of the typical group 5 trucks with different technologies

Vehicle	Specs
Conventional ICE vehicle without ADAS	Fleet average vehicle of group 5-LH created on the basis of the monitoring data for the baseline year 2019/20 Diesel engine 350 kW, AMT 12 transmission
Conventional ICE vehicle with ADAS	as above + ADAS configuration 8/2 (PCC 1+2+3 with Eco-roll without Engine Stop-Start) ²
Full-Hybrid Electric Vehicle	as Conventional ICE vehicle with ADAS and additionally fully hybridised, i.e. P2 configuration, 140 kW EM, 10 kWh battery
Mild-Hybrid Electric Vehicle	as Conventional ICE vehicle with ADAS but additionally with "mild" hybrid, i.e. P1 configuration, 20 kW EM, 2.5 kWh battery
Battery Electric Vehicle	Configuration E4 (wheel hub motors), 2x 157 kW EM, 500 kWh battery

The energy consumption of the first vehicle (Conventional Class 5 tractor without ADAS) was used as reference. The reduction in energy consumption of each technology (ADAS, hybridization, etc.) was then evaluated. For the four first vehicles the CO₂ emissions are used to evaluate energy consumption. For the battery electric vehicle, the consumed electric energy is used.

2.2.3.2 Selection Criteria

In the following, the selection criteria are listed separately according to energy consumption related or altitude related.

Energy criteria

1. The consumption of each cycle is calculated and compared with the consumption of the current long-haul mission profile. The calculation is performed only for the conventional group 5 tractor without ADAS. Cycles that have small deviation from the current long-haul are preferred.
2. The consumption of the glass 5 truck with ADAS is compared to the consumption of the group 5 truck without ADAS. The benefit of the ADAS technology for each cycle is calculated.³ The cycles that have benefit close to the average benefit of all two hundred cycles are preferred.
3. The consumption of the group 5 full hybrid with ADAS is compared to the consumption of the conventional group 5 vehicle without ADAS. The benefit of the HEV+ADAS technology

² Same vehicle configuration as used in the trailer tool

³ In this analysis, both payloads as defined in the VECTO Declaration mode were simulated, the fuel consumption results were consolidated using the applicable weighting factors (30% low payload, 70% representative payload) and the effect of ADAS was determined on the basis of this consolidated value.

for each cycle is calculated. The cycles that have benefit close to the average benefit of all two hundred cycles are preferred.

4. The consumption of the group 5, mild hybrid with ADAS is compared to the consumption of the conventional group 5 without ADAS. The benefit of the mild HEV+ADAS technology for each cycle is calculated. The cycles that have benefit close to the average benefit of all two hundred cycles are preferred.
5. The consumption of the battery electric vehicle is calculated for all cycles. The cycles that have consumption close to the average of all two hundred cycles are preferred.

Altitude criteria

1. The distribution of the gradient profile is calculated for each cycle and compared with the distribution of the typical routes. The comparison is performed with the chi-square method. Specifically, the distribution of the gradient profile of the typical routes is set as the expected value. Then, the distribution of a generated route is set as the observed value. The deviation of the two is calculated. Based on that deviation, we can deduce if the two distributions are significantly different in statistical terms.
2. The altitude and velocity profiles are analysed to identify sections where there is simultaneously steep uphill and acceleration or steep downhill and deceleration. An indicator is created to evaluate each cycle based on that criterion, and a limit value is set.
3. Cycles that have large sections with steep slope are not preferred. To evaluate that the percentage of the cycle that has road slope steeper than plus or minus 6% is calculated. Cycles where that percentage is less than 1 % are selected.
4. Cycles with steep downhill in the first kilometres are not preferred. The reason in that hybrid or battery electric vehicles will lose the potential to gain energy, as the battery is already full. To account for that, the maximum altitude difference in the first 2 km is calculated. A positive sign means that the difference in altitude in the first 2 km is positive (uphill) and a negative that it is negative (downhill). Cycles with positive altitude difference are preferred.⁴
5. The maximum altitude difference in the entire cycle is calculated. Ideally, we would like that parameter to remain the same in the new profile compared to the original long haul cycle.⁵
6. The variance of the slope for the entire cycle is calculated. All cycles had smaller slope variance compared to the input routes. Thus, the cycles with large slope variance were preferred.

Target values

Ten of these criteria were defined quantitatively. These are listed in Table 4.

⁴ In the meantime, it has become clear that the starting SOC in the VECTO simulations will probably be selected as 50%. This criterion is therefore no longer so important.

⁵ The maximum altitude difference over the cycle was one of the 'design criteria' of the original LH cycle based on real world data.

Table 4: Overview of selection criteria and their limits

Criterion	Target value	Min accepted	Max accepted
<i>Consumption of Class 5 Tractor</i>	0.0 %	-2.5 %	2.5 %
<i>Benefit for Class 5 Tractor with ADAS</i>	2.01 %	1.66 %	2.36 %
<i>Benefit for Hybrid</i>	4.42 %	4.07 %	4.77 %
<i>Benefit for Mild Hybrid</i>	2.55 %	2.20 %	2.90 %
<i>Consumption of BEV</i>	0.0 %	-2.0 %	2.0 %
<i>Acceleration and slope</i>	-	0	2
<i>Steep slopes</i>	-	0 %	1 %
<i>Altitude difference in first 2 km</i>	-	0	-
<i>Min to Max altitude in cycle</i>	177	-	195
<i>Slope variance</i>	-	2.65	-

Final selection

These 11 criteria were evaluated, for all cycles. Due to the large number of criteria, there was no cycle that could fulfil them all perfectly. Thus, a decision method was established. First, the cycles are sorted based on their performance on the chi-square test that is used to compare their gradient distribution with the typical routes. The worse one hundred cycles (bottom half) are excluded independent of their performance in the rest criteria. Then, the first consumption criterion, which quantifies the deviation of consumption from the current long-haul, is considered. Any cycle that does not fulfil it is excluded independent of its performance in the rest criteria. The cycles are then sorted based on the number of the other 9 criteria they fulfil. In case that two cycles fulfil the same number of criteria the cycle that performs better in the consumption criteria is preferred.

2.2.4 Suggested cycle

The best cycle, based on the analysis that is presented above, is cycle # 157. In Figure 12 the altitude profile and the wavelength content of the slope distribution are shown. The same parameters are included for the original long-haul mission profile.

Regarding the altitude profile, there are large similarities between the two cycles in the first half of the mission profile (left picture). The main differences are observed after kilometre 50, where the smooth downhill section of the original profile is replaced by a more hilly section. As envisaged, the wavelength content of the new profile is very closer to the average of the 18 typical routes (right picture).

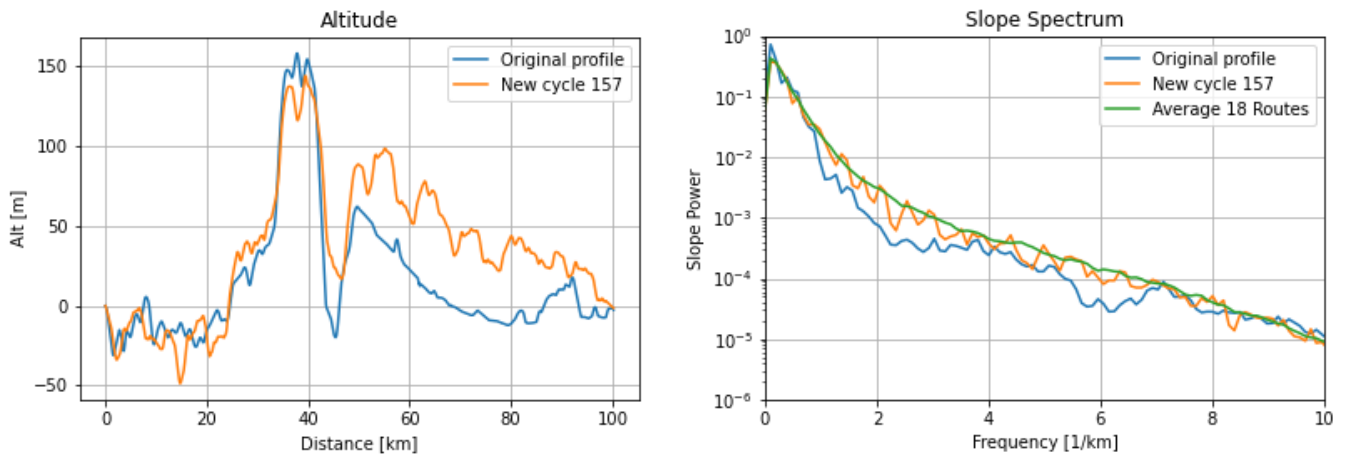

Figure 12: a) Altitude profile of the current long-haul mission profile and of the suggested new mission profile, b) wavelength content of the current long-haul mission profile, the average typical routes and the suggested new mission profile

The new cycle has a positive elevation gain of 523 meters which is slightly increased compared to the original long haul. Two criteria were not fulfilled by cycle # 157. The first one is altitude criteria #4 (downhill at first kilometres) which is not fulfilled as the cycle starts with a downhill part in the first few hundred meters.⁶ The second is altitude criteria #6 (slope variance) which is underrun by cycle # 157. All other altitude criteria as well as all the consumption criteria are satisfied. The values of the most relevant criteria are shown in Table 5, and they are within the acceptable limits presented in Table 4.

⁶ However, this is de facto not relevant for the cycle, see footnote 4 on page 28.

Table 5: Most relevant properties of the suggested new mission profile

Criterion	Cycle #157	Average all cycle candidates	Original LH cycle
Benefit of ADAS for conventional truck	2.21 %	1.91%	1.10%
Benefit of ADAS for P2 HEV	4.27 %	4.66%	2.91%
Benefit of ADAS for P1 mild HEV	2.74 %	2.51%	1.48%
Consumption of BEV [kWh/km]	1.850	1.861	1.889
Maximum altitude delta within cycle [m]	193.3	213.7	189.5
Change in CO ₂ to current LH for conventional vehicle	-2.15 %	-0.89%	---

This analysis was first presented and discussed internally with DG CLIMA and JRC in March 2022 and then in a dedicated stakeholder meeting (16th of March 2022). It was decided to adopt cycle #157 as the new long haul cycle.

2.3 Subtask 1.3: Assess impact of the update on CO₂ emissions

This subtask should assess the difference of the impacts of ADAS systems on the reduction of fuel consumption, simulated for the existing and the adjusted VECTO long haul mission profile. For the analysis, the typical 2019/2022 group 5 vehicle model was used, which was already applied in subtask 1.2. The following three ADAS benefits are compared:

- 1) ADAS Phase 1 implementation as part of the official VECTO versions up to 3.3.10 with fixed CO₂ reduction rates per vehicle group and payload condition
- 2) ADAS Phase 2 implementation (“in-the-loop”) as developed in the specific contract No 340201/2018/776882/SER/CLIMA.C.4 and part of the official VECTO versions from 3.3.11 (May 2022) on and using the original LH cycle for the simulations
- 3) Implementation as in 2) but using the updated LH cycle for the simulations

The results of this comparison are shown in Table 6. The “quick fix” values were deliberately chosen conservatively in 2018 because the final algorithm for simulating ADAS in VECTO had not yet been developed and a lowering of assigned technology benefits were to be avoided for the second implementation phase. Therefore, the quick fix values are about a factor of 2 below the in-the-loop values based on the original LH cycle.

As already mentioned in the previous sections, the new cycle results in consistently higher technology benefits from ADAS, i.e. again approximately a factor of 2 is found between the results with the updated LH cycle and the original cycle. This fact is also shown graphically in Figure 13.

Table 6: Comparison ADAS technology benefits

ADAS Comb. Nr.	Engine stop-start during vehicle stops	Eco-roll without engine stop-start	Eco-roll with engine stop-start	PCC (1, 2)	PCC (1, 2, 3)	"Quick fix" bonus factors as applied in official VECTO until versions 3.3.10		ADAS simulated in-the-loop			
								original LH cycle		updated LH cycle	
						payload low	payload rep.	payload low	payload rep.	payload low	payload rep.
1	yes	no	no	no	no	-0.1%	0.0%	-0.1%	0.0%	-0.1%	0.0%
2	no	yes	no	no	no	0.0%	-0.1%	0.0%	0.0%	-0.1%	0.0%
3	no	no	yes	no	no	-0.1%	-0.2%	0.0%	0.0%	-0.1%	0.0%
4/1	no	no	no	yes	no	-0.2%	-0.5%	-0.2%	-0.6%	-0.2%	-1.4%
4/2	no	no	no	no	yes	-0.2%	-0.7%	-0.2%	-0.9%	-0.2%	-1.8%
5	yes	yes	no	no	no	-0.1%	-0.1%	-0.1%	-0.1%	-0.1%	-0.1%
6	yes	no	yes	no	no	-0.1%	-0.2%	0.0%	0.0%	-0.2%	-0.1%
7/1	yes	no	no	yes	no	-0.2%	-0.5%	-0.2%	-0.6%	-0.2%	-1.4%
7/2	yes	no	no	no	yes	-0.3%	-0.7%	-0.2%	-1.0%	-0.3%	-1.9%
8/1	no	yes	no	yes	no	-0.2%	-0.6%	-0.4%	-1.0%	-0.9%	-1.7%
8/2	no	yes	no	no	yes	-0.2%	-0.7%	-0.4%	-1.3%	-1.1%	-2.6%
9/1	no	no	yes	yes	no	-0.2%	-0.6%	-0.4%	-1.2%	-1.1%	-2.1%
9/2	no	no	yes	no	yes	-0.2%	-0.8%	-0.5%	-1.5%	-1.4%	-3.0%
10/1	yes	yes	no	yes	no	-0.2%	-0.6%	-0.4%	-1.0%	-0.9%	-1.7%
10/2	yes	yes	no	no	yes	-0.3%	-0.8%	-0.5%	-1.3%	-1.1%	-2.6%
11/1	yes	no	yes	yes	no	-0.3%	-0.7%	-0.5%	-1.2%	-1.2%	-2.1%
11/2	yes	no	yes	no	yes	-0.3%	-0.8%	-0.6%	-1.5%	-1.4%	-3.1%

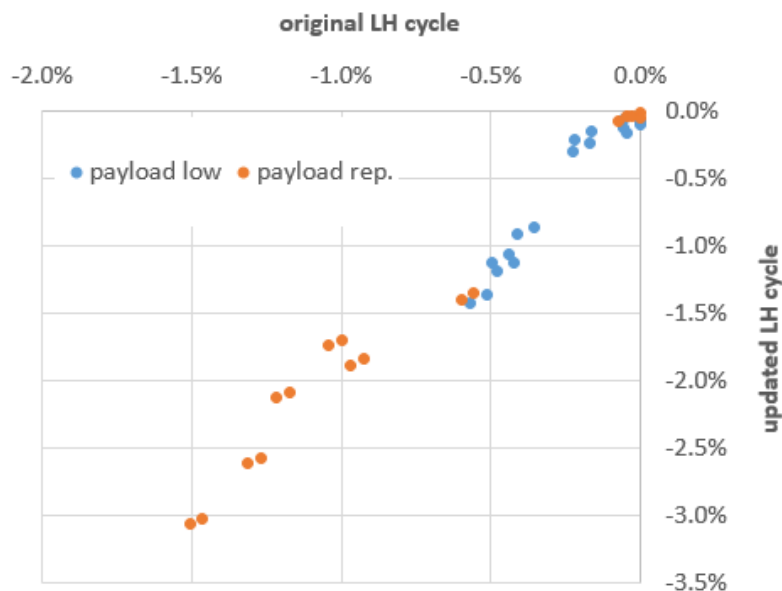

Figure 13: Comparison ADAS technology benefits as simulated by VECTO in-the-loop

2.4 Subtask 1.4: Implementation of updated mission profile

Subtask 1.4 should provide a smooth implementation of the updated mission profile into the operational official VECTO release and support the Commission in the elaboration of the adjustment factors to the reference CO₂ emissions for the CO₂ standards.

Part 1 of this subtask comprised the work on update of the simulation tool covering the implementation of the new mission profile into the declaration mode, updating the correlated test cases and the documentation. This part has been completed with the official release version 3.3.11.2675 as published on the 29th of April 2022.

Part 2 of this subtask dealt with the elaboration of adjustment factors to the reference CO₂ emissions of relevance for Regulation (EU) 2019/1242. An adjustment procedure is required not only because of the update of the long haul cycle, but also because of the following additional model changes in the official VECTO version 3.3.11 compared to the previous ones:

- Change of gear shift model (from "Classic" to "EffShift") for AMT and APT transmission type
- Model change regarding ADAS from fixed bonus factors ("Quickfix") to in-the-loop modelling.

Possible approaches on how this could be done in the most robust and practical way were analysed by TUG and discussed in meetings with DG CLIMA and DG JRC on 9 November 2021 and 21 July 2022. TUG was also involved in a further meeting including ACEA on 11 November 2022.

3 Task 2: Hydrogen vehicles operated with fuel cell or internal combustion technologies

Target of task 2 was to integrate propulsion technologies based on hydrogen fuel into VECTO and into the component testing procedures as prescribed in Regulation (EU) 2017/2400. Hydrogen fuelled vehicles can either burn hydrogen solely or in combination with other fuels in an internal combustion engine or use fuel-cell technology to generate electric energy to drive a fully electric vehicle. In this task the knowledge related to fuel cell technology was provided by HyCentA Research GmbH.

Chapter 3 documents the work carried out on this in the project, according to the task distribution in the project:

- Subtask 2.1: Collection of feedback on the operation of VECTO for vehicles with electrified powertrains (section 3.1)
- Subtask 2.2: Fuel cell electric vehicles (section 3.2)
- Subtask 2.3: Internal Combustion Engines (partly) operated with hydrogen fuel (section 3.3)

Furthermore, section 3.4 gives the formulas for calculating the range with hydrogen or the zero CO₂ emission range, which are valid for all types of hydrogen-powered vehicles.

3.1 Subtask 2.1: Collection of feedback on the operation of VECTO for vehicles with electrified powertrains

Subtask 2.1 covered the collection of feedback from industry and other relevant stakeholders on the operation of the VECTO tool regarding simulation of vehicles with electrified powertrains (hybrid electric vehicles, battery electric vehicles) as developed under the Service Contract Number 340201/2018/776882/SER/CLIMA.C.4. The investigations covered both the modelling of electric components and the full vehicle simulation. This sub-task had the background that fuel cell vehicles, with the exception of the fuel cell system itself, have the same powertrain components as the above mentioned xEV concepts and therefore also basically use the same simulation methods in VECTO. The feedback process was organised through the regular VECTO Development workshops. Further feedback was gained from the JRC's "prove of concept" study for xEV as it was carried out in 2022/23.

From all available information, no issues are known that would put the good functioning of the basic xEV methods in VECTO in question. The only feedback item requiring action was the shortcoming of the parallel HEV strategy and the associated gear shift strategy, which was identified in the course of the JRC analyses of the measurement data from the IHPC vehicle. This problem was fixed in the course of the work in Specific contract No 090203/2021/863026/SER/CLIMA.C.4 ("VECTO Extension to Cover Electric Vehicles and Additional Powertrains", which covers the

implementation of IHPC in VECTO), and released in development versions from March 2023. This fix improves the gear shift strategy for all parallel hybrid configurations in VECTO.

3.2 Subtask 2.2: Fuel cell electric vehicles

The work to be performed in this task to integrate fuel cell (FC) technologies into VECTO was structured into four work packages (WP 2.2.1 to WP 2.2.4).

- WP 2.2.1: Review HDV FC technologies and legislation
- WP 2.2.2: Elaboration of a component testing procedure
- WP 2.2.3: Vehicle simulation approach in VECTO
- WP 2.2.4: Validation

3.2.1 Work package 2.2.1: Review technologies and legislation

The following tasks were allocated to WP 2.2.1:

- Current HDV FC technologies and existing standards on testing procedures and fuel cell development and homologation were analysed. This content is presented in section 3.2.1.1.
- Possible fuel cell vehicle powertrain configurations (fuel cell dominant, mid-size and range extender) and their respective modularity are analysed regarding their impact on a future CO₂ legislation based on VECTO (section 3.2.1.2).

3.2.1.1 Review of existing technologies and standards

In transportation, an increasing number of hydrogen-powered vehicles are becoming commercially available in medium-sized and large cars, buses, trucks, vans, trains, and forklifts. In these segments, fuel cell vehicles (FCV) meet the performance and convenience requirements best. In the next wave, costs are likely to drop with scale, allowing hydrogen to compete in more segments such as smaller cars and minibuses. By 2030, 1 in 12 cars sold in California, Germany, Japan, and South Korea could be powered by hydrogen [4], more than 350,000 hydrogen trucks could be transporting goods, and thousands of trains and passenger ships could be transporting people without carbon and local emissions. Decarbonizing the segments is possible with a range of technologies that offer different energy efficiency (the energy required as input) and their energy density in terms of weight and volume (see Figure 14).

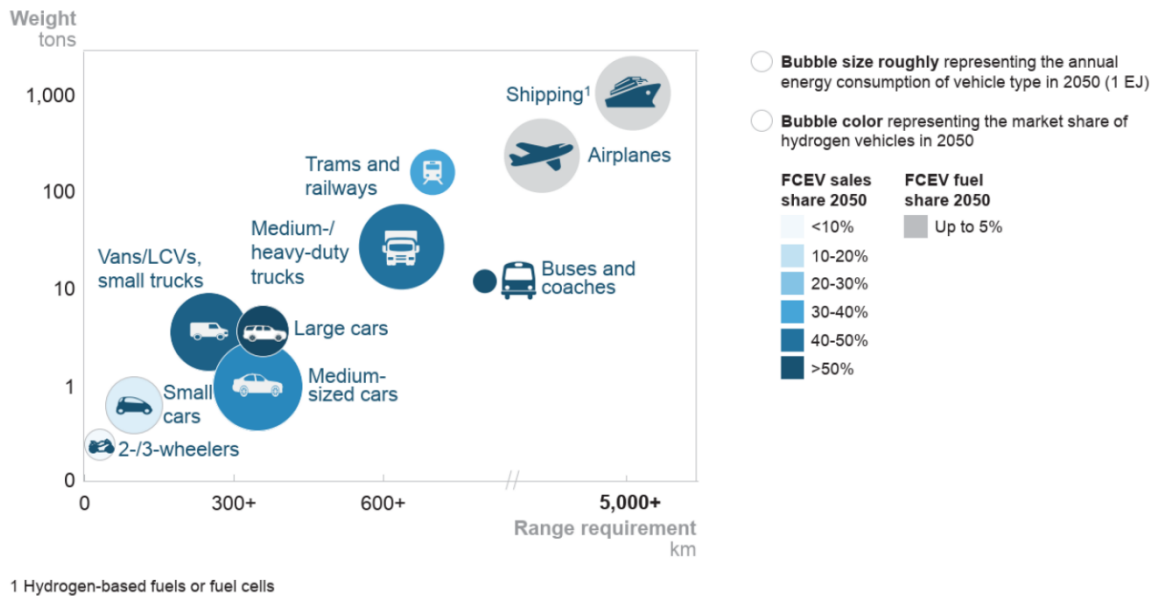

Figure 14: Transportation market sector share in 2050 for hydrogen applications [4]

Fuel cell technologies for HDV applications

Proton Exchange Membrane (PEM) fuel cell technologies have emerged as a promising solution for mobility applications. PEM fuel cells are particularly attractive for heavy-duty applications due to their high power density, rapid start-up times, and ability to operate efficiently at partial loads, which are essential characteristics for heavy vehicles and machinery. The technology offers advantages such as longer driving ranges and shorter refuelling times compared to battery-powered alternatives, making them suitable for long-haul transportation and intensive industrial operations.

Researchers and engineers have made significant progress in improving the performance and durability of PEM fuel cells in heavy-duty applications. Ongoing research focuses on enhancing the materials used in the cell's construction, optimizing the catalysts, and improving water and thermal management systems to further increase their efficiency and reliability.

As technology advances and infrastructure for hydrogen production and distribution expands, PEM fuel cell technologies are poised to play a crucial role in transforming heavy-duty transportation and industries, offering cleaner and more sustainable alternatives to traditional fossil fuel-powered vehicles. Striving towards a common standard, OEMs and suppliers focus on PEM stacks technology. Nevertheless, the typically stationary load profile of a HD truck might in the future open some opportunities offered by development Solid Oxide Fuel Cells (SOFC) and High Temperature Polymer Electrolyte Membrane Fuel Cells (HTPEMFC). While SOFCs present several advantages as usage of a broader range of fuels, cogeneration capabilities and high system efficiency, they are considered niche products in heavy-duty applications. Firstly, their high operating temperature requires a longer start-up time, which may not be ideal for certain mobile applications that demand instant power availability. Secondly, their complexity and sensitivity to thermal cycling present challenges in terms of durability and reliability for mobile operations, such as heavy-duty trucks that frequently start and stop. One of the key benefits of HTPM fuel cells in heavy-duty applications is their ability to tolerate impurities in the hydrogen fuel. This feature allows for the utilization of less pure hydrogen, which can be advantageous in situations where access to high-purity hydrogen is



challenging or expensive. Another advantage, due to the higher operating temperatures (typically between 120-200°C), concerns the thermal management and thus the packaging of the vehicle. However, this technology is currently still in the development stage and part of current R&D activities and should currently be seen as a pure niche application, e.g. as an external energy supply. cp. [5]

Review of FCV HDV applications

The summary includes typical use cases, technical layouts and targets, commercial vehicle and market, mainly for trucks (road freight) and buses. Trains, ships and aircraft are also considered heavy-duty applications in principle, but are not discussed further here.

Road freight FCV use cases

The road freight sector includes commercial vehicles ranging from light-duty vans up to long-haul articulated trucks or even road trains. Light-duty vans are linked to the same load cycles of the automotive sector, but with some specific focuses like high availability and long durability. Since the vehicle GCW is limited to 3.5 t, the weight of the FCS is of primary importance to allow the highest payload. This specific aspect, together with short refuelling and longer autonomy, can make FCVs attractive against equivalent BEVs for specific implementations. Heavy-duty trucks on the other hand are meant to travel longer distances at constant medium load. This driving profile represents the ideal use case where most of the FCEVs technical strengths are showcased, making them particularly competitive in comparison with BEVs. However, successful commercialisation will depend on lowering the total cost of ownership (TCO) of these vehicles. A report of the EU FCH JU [6] analyses the market potential of FCV HD trucks in Europe for three use case segments (long-, medium-, short-haul), which account for approximately 53% of HDT market sales in Europe.

	Use case I	Use case II	Use case III
Segment	International logistics National logistics Manufacturing industry	Wholesale	Regional logistics Retail
Truck segment	HDT (40 t)	HDT (27 t)	HDT (18 t)
Truck characteristics	Tractor 4x2 	Rigid 6x2 	Rigid 4x2 
Route type	Long distance	Long distance	Distribution
Route characteristics	~140,000 km p.a. ~570 km per day	~95,000 km p.a. ~380 km per day	~60,000 km p.a. ~250 km per day
Average new truck sales in Europe p.a.¹	~100 k trucks (~28% of market)	~20 k trucks (~6% of market)	~70 k trucks (~20% of market)
Typical operators	National and International logistics companies Manufacturing companies with own trucking fleet	Wholesalers with own trucking fleet	Logistics companies Retailers with own trucking fleet

1) Total European market is approximately 360,000-370,000 new trucks p.a.

Figure 15: Description of the three EU FCH JU analysed use cases [6]

Technical truck layout and targets

Light-duty vans share the technical layout already seen in the automotive sector. HD trucks also inherit the same electrical scheme with battery and FC connected in parallel. Their tubular frame with cab on top leaves nevertheless an open choice of different component layouts.

In many research projects and in FC retrofitting of e.g. diesel trucks, the space behind the cabin offers the easiest possible implementation option: some or even all FCS components are mounted in a rack frame and then connected to the electric motor, which transmits torque to the wheels via a conventional automatic transmission. Even at a higher level of integration, the place behind the cab is still commonly used to accommodate the hydrogen tanks piled up to reduce to the minimum the length subtracted to the trailer. The FC system maximum power lies in the range between 100 and 200 kW. Based on the performance requirements of the vehicle, the FC systems can be modularly expanded and integrated (see also 3.2.1.2).

The fairly stationary medium load at which the electric powertrain works most of the time is also the reason why a FC dominant approach is discarded: in medium- or long-range trucks the FCS usually covers only up to 60 % of the motors power. Lithium batteries are much smaller in comparison to comparable battery-based trucks, but still in the order of magnitude of a big sedan (i.e. around 100 kWh) with max charge and discharge power up to several hundreds of kW. These are normally mounted on the side of the tubular frame.

Hydrogen storage has not reached common standard either, as all CGH₂ at 350 and 700 bar as well as LH₂ cryogenic vessels can be found in the current applications range.

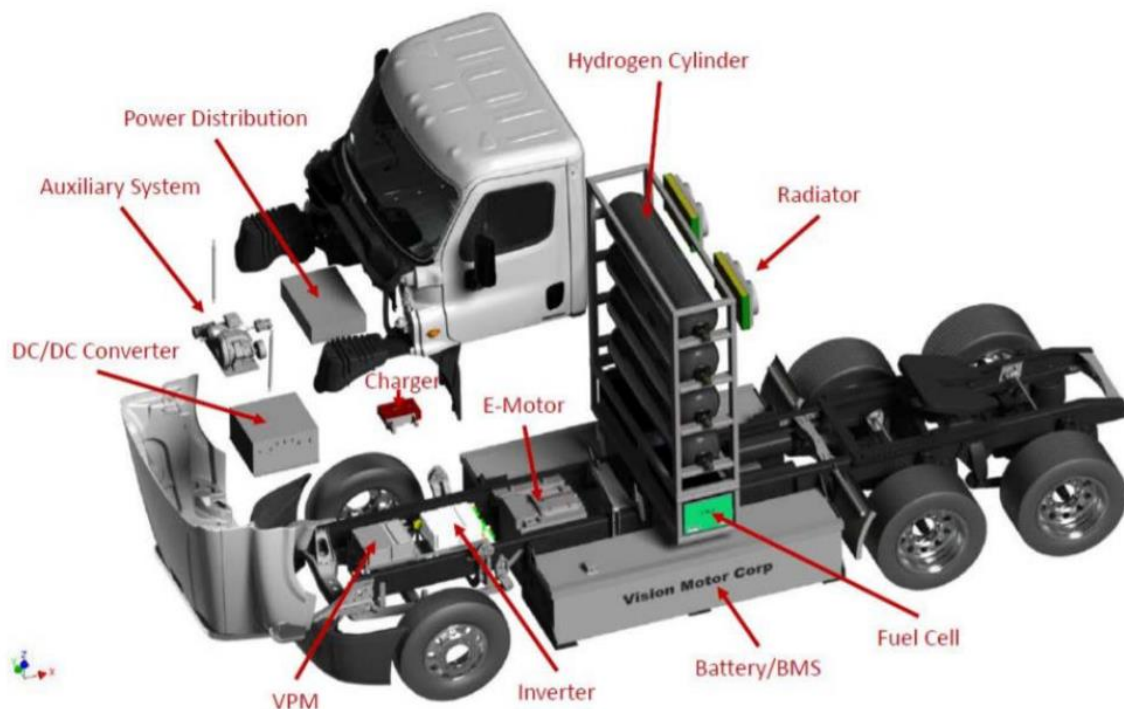

Figure 16: FCV truck schema, Vision Industries Corporation 2014 [7]

FCV technology in the heavy-duty truck sector still faces several barriers before a commercial roll-out is possible. They are mainly related to the relative novelty of the technology for this application and initial support is needed to unlock its full market and decarbonisation potential.

US DoE Technical Targets for Long-Haul Trucks Fuel Cell System Operating on Hydrogen Target includes FC stack, BoP and thermal system. Target excludes H ₂ storage, battery, electric drive and power electronics. Test case: 750 miles between refueling				
Characteristic	Units	2020 SoA	2030 Targets (Interim)	Ultimate Targets ⁸
Peak energy efficiency (Ratio between DC output energy and H ₂ LHV)	%		68	72
Fuel Cell System Cost ^{2,3}	\$/kW _{net}	~190 ⁴	80	60 (against diesel benchmark \$23400 / 390kW = 60\$/kW)
Hydrogen storage system cost ³ (includes the storage tank and all necessary balance-of-plant components)	\$/kWh \$/kgH ₂	15 ⁷ 500	9 300	8 266
Fuel cell system lifetime ¹ (<10% loss of performance in real world operating conditions)	h	>30000	25000	30000
Hydrogen Fill Rate	kg H ₂ /min		8	10
Storage system cycle life ⁵	cycles		5000	5000
Pressurized storage system cycle life ⁶	cycles		11000	11000

Figure 17: Targets for long-haul trucks from US DoE [8]

The FCS lifetime target of 30k hours set by the US DoE corresponds to an average driving speed of 40 mph over a vehicle lifetime of 1,200,000 miles. It is interesting to note that these targets do not consider overnight use of the fuel cell for hotel loads, which would add as much as 10,000 hours of operational time over the course of 500,000 miles. The reason is that FC usage to directly meet the hotel loads would require the fuel cell to operate at low power/high cell voltage, conditions that increase cell degradation. The US DoE recommendation is to use the battery pack for overnight electrical loads. FC cost targets for trucks are higher than fuel cell cost targets for light-duty vehicles (LDVs), primarily because of the higher durability required for trucks vs. cars (i.e., 25,000 to 30,000 hours for trucks vs. 8,000 hours for cars), but also because highway trucks have a relatively higher continuous load compared with automotive systems necessitating a larger fuel cell stack size. Fuel cost for long-haul trucks is much higher than the capital cost of truck, so investing in higher efficiency reduces the overall cost of ownership. Features were included in the design for improved durability such as including relatively high catalyst loading, graphitic bipolar plates, a moderate operating temperature, and thicker membranes.

FCV commercial HD vehicles trends

As for the automotive (passenger vehicles) applications, a linear relationship between on-board stored H₂ mass in and installed FC power is given. The 700 bar implementation for the LCVs is most probably to be linked to the space and payload limitation characteristic of the 3.5 t vehicle class. Medium range trucks seem to have found a satisfying storage solution with pressure at 350 bar, with available storage space on the trailer and a necessary autonomy up to 500 km. For longer ranges, CGH₂ is again reintroduced by Nikola and Kenworth at 700 bar, whereas Mercedes is the only manufacturer to hint cryogenic LH₂ implementations as they aim to reach an autonomy of 1000 km.

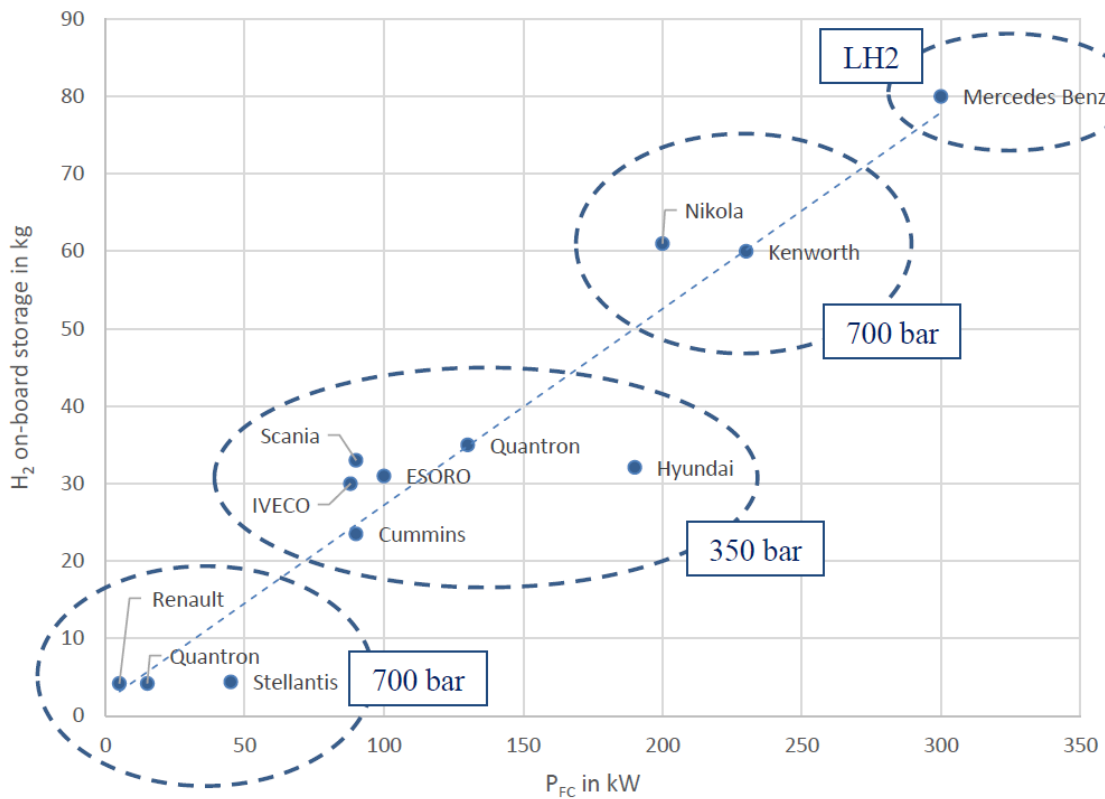

Figure 18: On-board stored H₂ in relation to the installed FC power for commercial vehicles

An analysis of the powertrain approach shows also a similar trend compared to the automotive sector with the fundamental difference that FC dominant solutions are discarded, since the typical load profile of a HDV is much more stationary at a medium load in comparison to passenger cars. Therefore, the FC is mainly dimension for this base load whereas the battery takes care of the relatively rare accelerations and braking.

The Kenworth T680 from the Project ZANZEFF is in this case the only outlier and the reason can be found in the limited capacity of the Li-ion battery. This may be due to the scope of the project itself, concentrated on the integration of the FC itself, rather than on the development of the most efficient energy management.

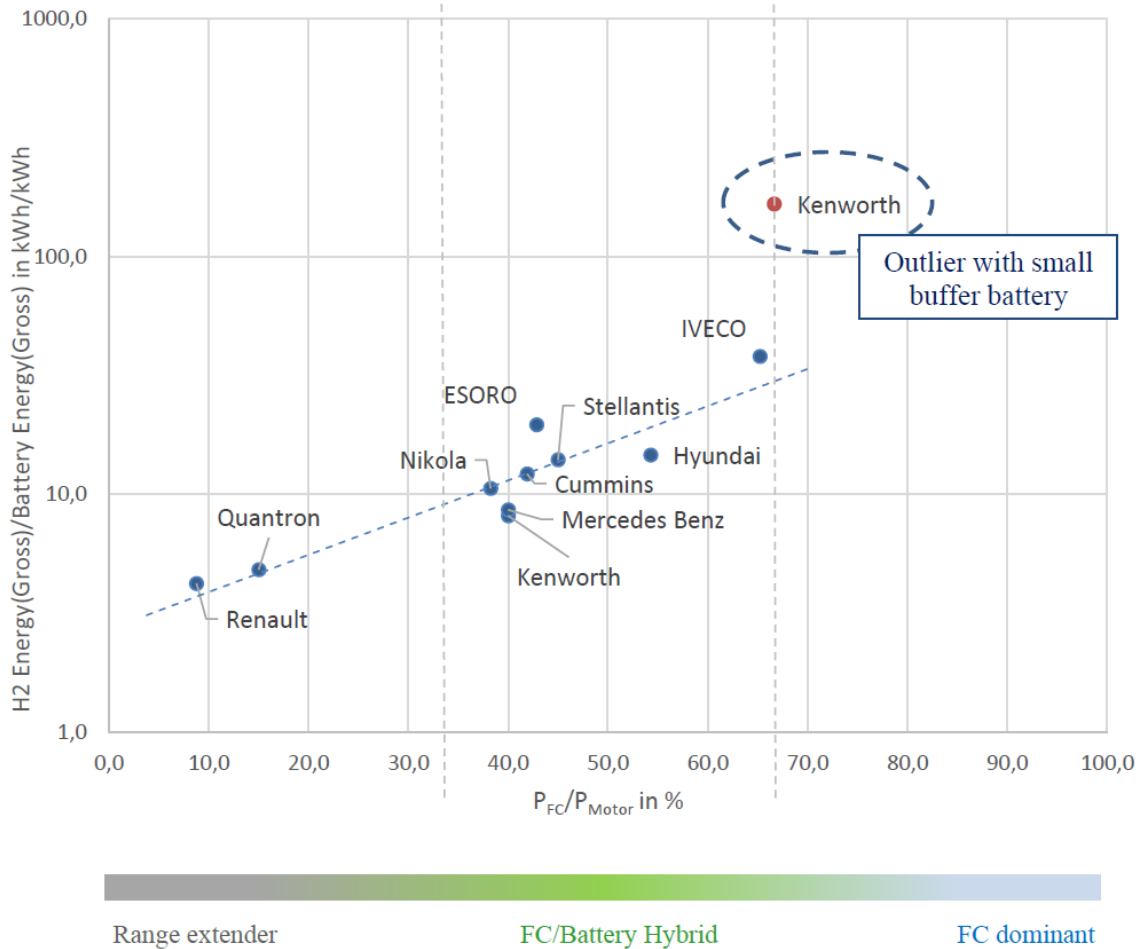

Figure 19: Hydrogen to battery on-board stored energy ratio depending on powertrain strategy

Light-duty FCV commercial vans (LCVs) are currently part of the rapidly evolving FC automotive market. The two forthcoming European applications (Renault Master and Citroën Jumpy) are the result of new cooperations announced in 2021: Stellantis revealed a strategic partnership with Faurecia and Symbio [9]; Renault signed a new Joint Venture with Plug-Power called Hyvia [10]. Both LCVs are modified BEVs with the aim of an extended range paired with competitive payload. These key figures are compared in Table 9 for all Opel Vivaro powertrain options.

Opel Vivaro	Unit	Diesel	Battery 50 kWh	Battery 75 kWh	FCH
On-board energy (gross, equivalent)	kWh	800 ¹	50	75	157 ²
Range (WLTP)	km	1,660 ³	230	330	400
Payload	kg	1,400	1,275	987	1,100
Starting price (approx.)	€	28,000	35,000	43,000	tba

1 Tank capacity 80 liters, diesel density 0.846 kg/l, LHVdiesel = 11.83 kWh/kg

2 As sum of 4.4 kg hydrogen and 10.5 kWh lithium battery, LHVH2 = 33.33 kWh/kg

3 Combined fuel consumption for 1.5 l, 120 hp diesel engine = 4.8 l/100km

Figure 20: Range and payload figures for the available Opel Vivaro powertrains [11]

The Renault Master should as well step up from 120 km in the BEV configuration with 33 kWh to 350 km guaranteed by 4.18 kg of hydrogen for the FC version. Nevertheless, the Renault Master technical data rely on a previous technical sheet released in 2019 and based on a FCS layout supplied by Symbio [12] which never entered into the market. The new Joint Venture with Plug-Power might bring to new technical stats. The main difference between the Master and Vivaro FCs is given by the FC maximum power: Renault has opted for a simpler REx solution based on a 5 kW FC, whereas Stellantis announced a full hybrid solution relying on the newly released 45 kW “StackPack M” FC from Symbio.

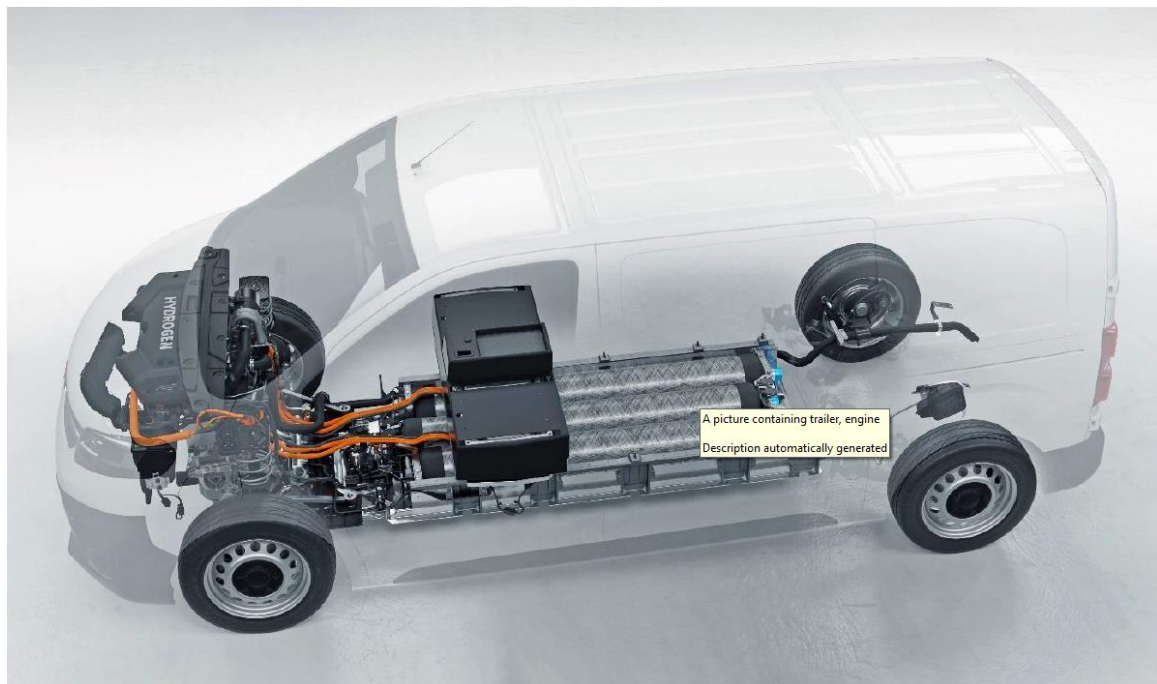

Figure 21: Opel Vivaro-e HYDROGEN components layout [11]

Long range trucks represent a highly attractive FCS use case. Nevertheless, existing hydrogen refuelling stations (HRS) are dedicated to the use of passenger vehicles and cannot be used by HD trucks due to different technological requirements for filling up the much larger truck tanks [6]. For this reason, many European and US pilot projects are rather local and often coupled with the

installation of a dedicated HRS. The aim of these projects is to attract the interest for further investments and push for a broader HD hydrogen infrastructure.

In 2016 the US company Nikola unveiled a first prototype called Nikola One which was characterised by impressive numbers: 1000 kW of maximum power, 800 km of autonomy and other outstanding technical features. Other US projects rely on a partnership with Japanese Manufacturers, like the Hydrotec JV between GM and Honda, or the ZANZEFF project of Kenworth and Toyota based on the same FC stack used for the Mirai. In Europe projects are increasing in number. The joint venture between the OEM Hyundai Motor Company and the H2 infrastructure provider H2Energy plans to bring 1,600 Xcient FC trucks and the related H2 infrastructure to the Swiss market. Switzerland was chosen as the first country for the roll-out because local conditions are particularly favourable. A schematic representation of the Hyundai Xcient FC with its 2 Nexo FCs is reported in Figure 22 left. Mercedes has also unveiled a concept, based on cryogenic LH2 on-board storage system. The Mercedes-Benz GenH2 offers a range of more than 1,000 kilometres for long-haul transport. Customer trials are expected for 2023. A rendering can be seen in Figure 22 right. Robert Bosch GmbH presents the concept of the eDistanceTruck for long-haul transportation in 2020, see Figure 23.

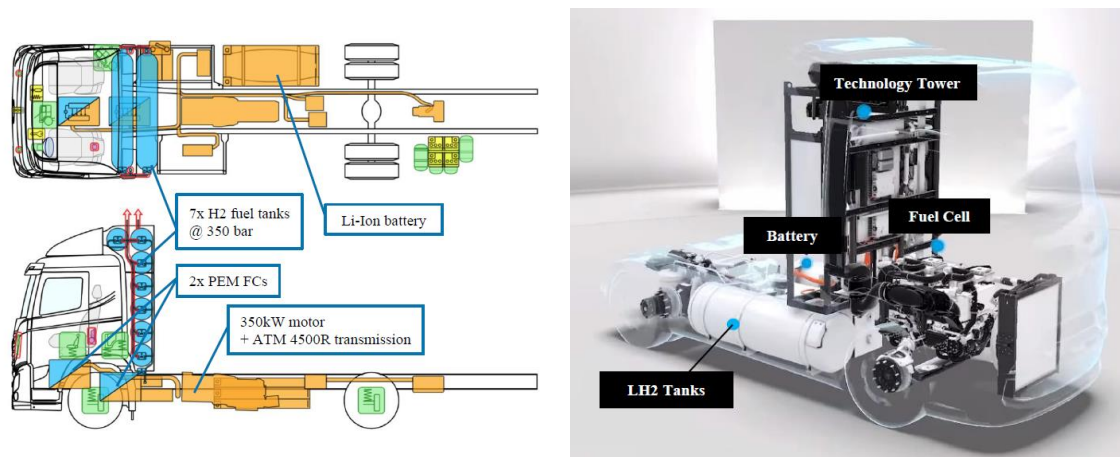

Figure 22: Left: Hyundai Xcient FC truck schematics [13], Right: Rendering of Mercedes-Benz GenH2 [14]

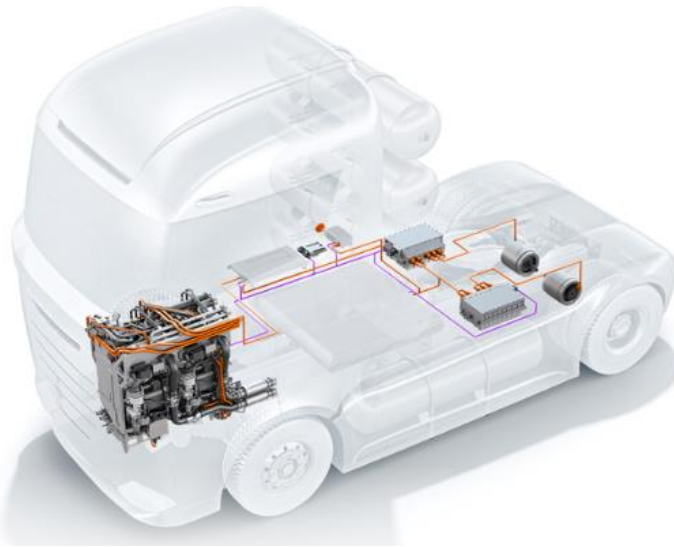

Figure 23: Bosch eDistanceTruck [15]

FCV buses use cases

The review of the hydrogen fuel cell buses and coaches highlights the 12 meters transit bus as the most appreciated use case for market developments. Some applications of 18 meters articulated buses can also be found, whereas the coach market seems to be remained unexplored, mainly due to the lack of a spread hydrogen distribution infrastructure. Flixbus (Europe's largest long-distance bus provider) and Freudenberg Sealing Technologies stated in September 2019 [16] [17] they intended to provide a demo fleet of fuel cell powered coaches, but no further developments have been disclosed since then.

Transit buses powertrain must cope with characteristic urban driving loads, made of repeated accelerations and breaking, almost no stationary operating points, long idling periods and demanding auxiliary loads (foremost air conditioning/heating). Long electric recharges would reduce bus availability and they would force public transport companies to extend the fleet with more vehicles. On the contrary, the average 10 minutes needed to refill the hydrogen tanks of a fuel cell bus resemble the required time of a common diesel-powered bus.

Technical H2 bus layout and targets

The straightforward and most common layout of low-floor transit buses see most of the main powertrain components placed on the roof. One or two FC systems for a total power between approx. 50 and 180 kW. Especially in bus applications, a significant amount of energy must be considered for interior conditioning (heating/cooling).

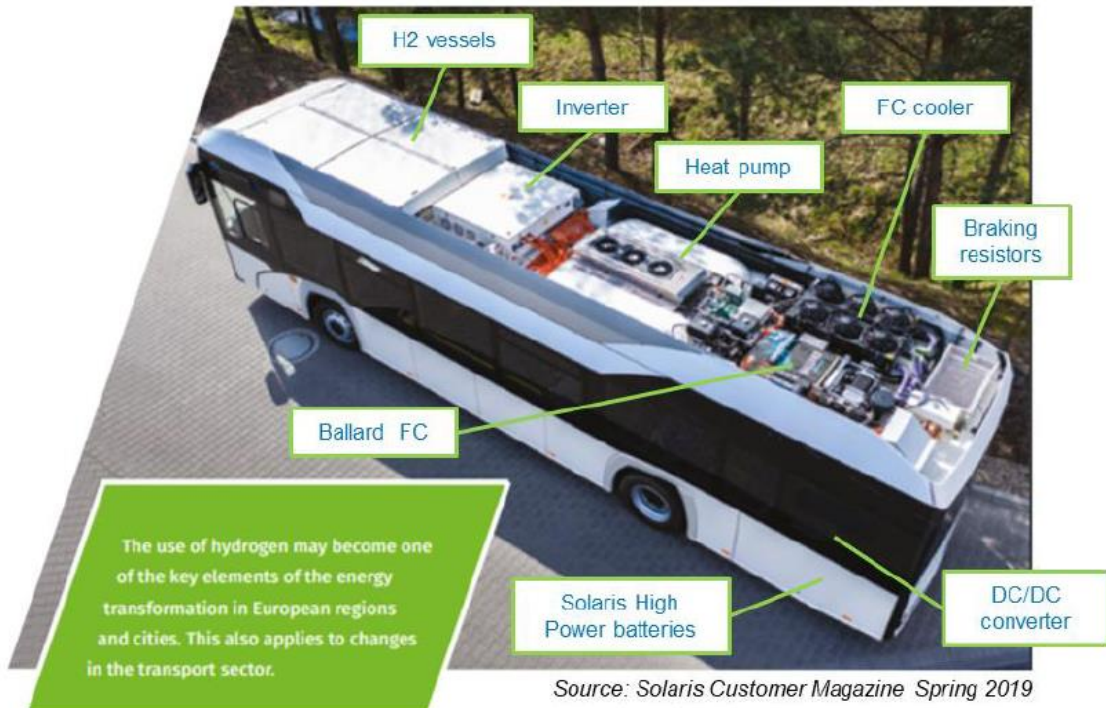

Figure 24: Solaris Urbino 12 Hydrogen layout [18]

The technical H2 bus targets are based on data of the US Department of Energy (DOE) and the US Department of Transportation (DOT).

No.	Parameter	Unit	STATE-OF-THE-ART AND FUTURE TARGETS (KPIs) as derived from the Multi Annual Work Plan Fuel Cell and Hydrogen - Transport Applications					U.S. DoE targets for FC transit buses
			SoA 2012	SoA 2017*	Target 2020	Target 2024	Target 2030	Ultimate target
1	Fuel cell system durability	h	10,000	16,000	20,000	24,000	28,000	25,000
2	Hydrogen consumption	kg/100km	9	8.5	8.0	7.5	7.1	8.8
3	Availability	%	85	90	90	93	93	90
4	Yearly operation cost (including labour)	€/year	-	-	16,000	14,000	11,000	Other parameter used
5	Fuel cell system cost	€/kW	3,500	1,500	900 (250 units)	750 (500 units)	600 (900 units)	Other parameter used
6	Bus cost	k€	1,300	650	625 (150 units)	600 (250 units)	500 (300 units)	600 k\$ (400 units)

Figure 25: Targets for long-haul trucks from US DoE [19]

The on-board stored H2 mass in relation to the installed FC power, represented in Figure 26, confirms a linear relationship. For buses and coaches, CGH2 with a storage pressure of 350 bar is actually the consolidated standard. However, three applications have been identified as trend

outliers (New Flyer Xcelsior CHARGE H2, Mercedes EvoBus Citaro FC Hybrid and Hyundai Elec City [20])

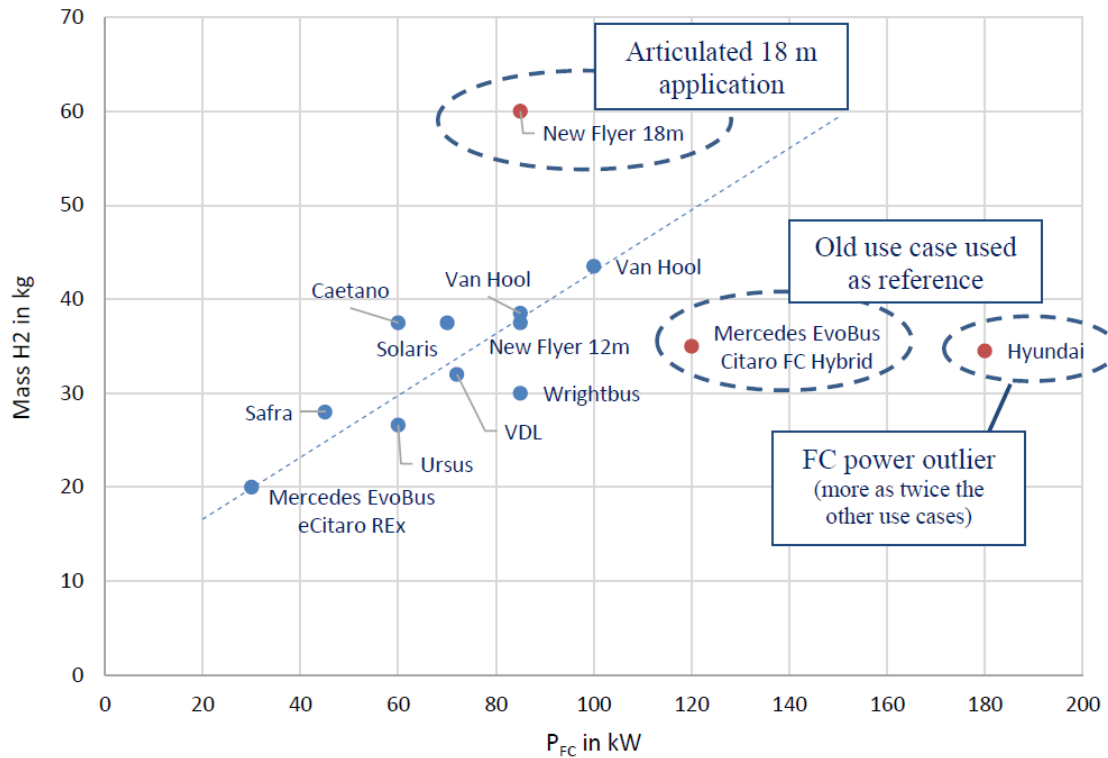

Figure 26: On-board stored H₂ in relation to the installed FC power for FCV buses

The powertrain strategy trend matches with the requirements of the typically low load profile of a 12 m transit bus with frequent stop and start manoeuvres. The FC maximum power covers in this case only up to half the electric motors peak power and also the exponential trend between energy ratio and power ratio ramps up much faster than for the commercial vehicles.

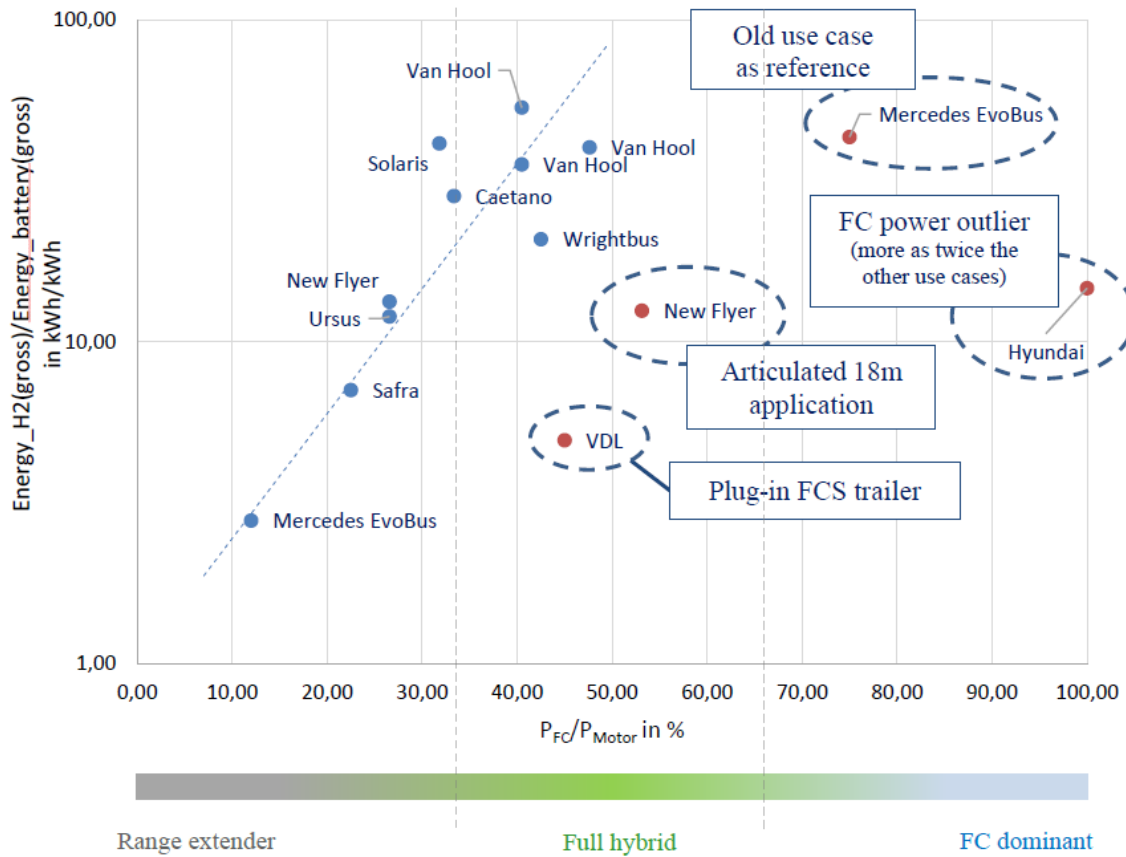

Figure 27: Energy ratio based on powertrain strategy for buses and coaches

FCV buses look technically mature and many vehicles are already commercially available. Orders are increasing by the hour, but in Europe this trend is very much pushed by the public funding coming from project JIVE 2 which will end at the end of 2023 [21].

A result of this support is nevertheless already noticeable. Despite the relatively new implementation, the FCV transit bus is today a product with already a clear consolidated standard that all manufacturers are willing to follow. This standard, as already shown in Figure 24, presents all main components mounted on the roof, in most cases with the only exception of some auxiliaries installed in the rear compartment. The installed single PEMFC stack is either from Ballard (see Van Hool, Solaris and New Flyer) or developed in-house (like Mercedes with the subsidiary Cellcentric, Toyota for the Sora and Hyundai for the Elec City). One alternative layout is offered by Wrightbus, which in 2018 unveiled the world-first FCV double-decker [22]: the Streetdeck FCV has a Ballard FCVelocity FC mounted low behind the rear-axle while the lithium-ion batteries are mounted just in front of the rear-axle. The hydrogen tanks are located in a rack at the back-end of the bus. A schematic representation of this layout can be seen in Figure 28.

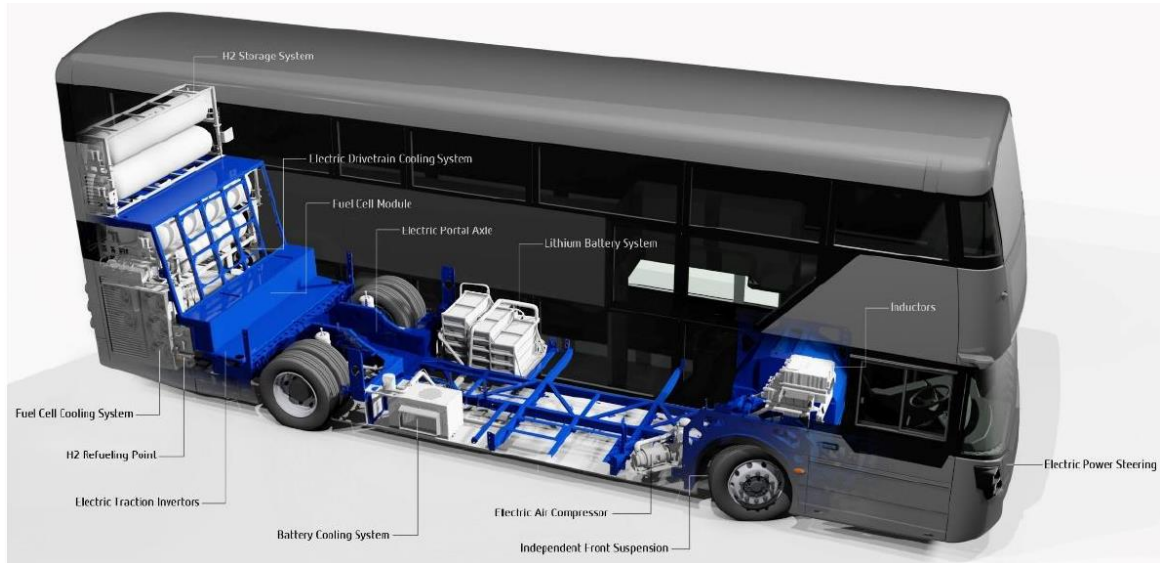

Figure 28: Wrightbus Streetdeck FCEV, the world-first double decker FCEV [22]

Standards and procedures for FC system testing

In order to define test procedures for FC systems, it makes sense to divide them into subsystems and, if necessary, into balance of plant components (BOPC). According to SAE J2615, a typical FC system contains several subsystems that are interconnected with each other. The schematic illustrates a generic FC system to be used for testing purpose. The large circular boundary indicates the boundary where performance parameters are to be measured.

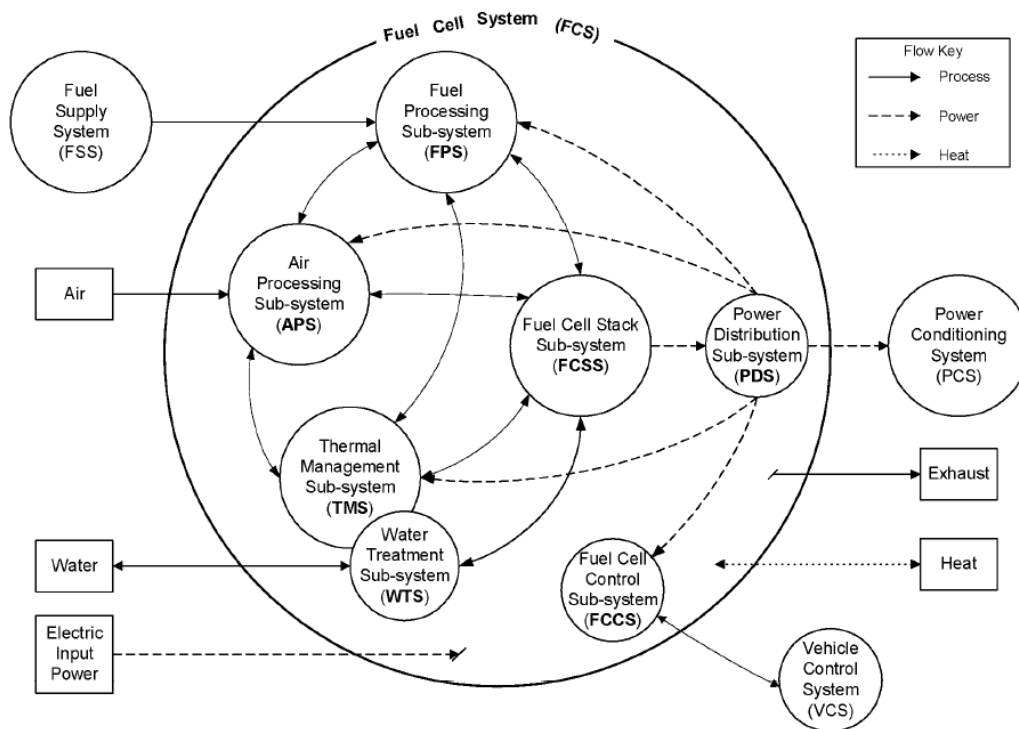

Figure 29: Fuel Cell System (FCS) by the SAE J2615 [22]

Short description of the subsystem is listed in Table XX.

Table 7: FCS Subsystems

FC subsystem	Description
Fuel Processing Sub-System (FPS)	Converts the supplied fuel to a form suitable for use in the fuel cell stack sub-system
Fuel Cell Stack Sub-System (FCSS)	Contains one or more fuel cell stacks that produces electric current by means of an electrochemical reaction of fuel and oxidant
Air Processing Sub-System (APS)	Delivers air (oxygen) for the reaction in the fuel cell stack sub-system
Thermal Management Sub-System (TMS)	Provides thermal and water management for the FCS
Water Treatment Sub-System (WTS)	Provides the treatment necessary for the process water used in the FCS
Power Distribution Sub-System (PDS)	Components that connect the fuel cell stack sub-system to the power conditioning system and that converts power for fuel cell system use. May include cables, switches, contactors, relays, buses, other connectors and instrumentation.
Fuel Cell Control Sub-System (FCCS)	Controls and/or monitors the fuel cell system conditions and automatically responds to vehicle power demands while preventing hazardous conditions and damages to the FCS
Power Conditioning System (PCS)	Components which convert the power generated by the fuel cell system into power useful for vehicular purposes. May includes voltage converter (DCDC) and/or inverters (DC/AC) that provide the interface between the FCS and the vehicle loads.
Related to SAE J2615	

Based on this definition, the test procedures are subsequently structured. Relevant BoPC are then part of the corresponding subsystem.

Currently, no standard is known that explicitly deals with PEMFC-based HDV and specifies specific test procedures. However, proposals can be derived from generally related standards that have been analysed (see Table 8)

Table 8: Testing standards

Type	Publisher	Publisher	No.	Category	Title	Date	Content	VECTO relevance
Standard	JIS	Japanese Standards Association	JIS C 8832	FC-Stack	Performance test for stationary polymer electrolyte fuel cell stack standard by Japanese Industrial Standard / Japanese Standards Association	Jan 2008 (2013)	Specifies the performance test for atmospheric pressure fuel cell stack of stationary polymer electrolyte fuel cell stack related to the power generation test.	-
Standard	SAE	SAE International	SAE J2617	FC-Stack	Recommended Practice for Testing Performance of PEM Fuel Cell Stack Sub-system for Automotive Application	Aug.11	Intends to serve as a procedure to verify the functional performance, design specifications or vendor claims of any PEM-FC-Stack sub-system for automotive applications. Definitions, specifications, and methods for the functional performance characterization of the sub-system are provided. The functional performance characterization includes evaluating electrical outputs and controlling fluid inputs and outputs based on the test boundary defined in this document.	~
Standard	ASME	American Society of Mechanical Engineers	ASME PTC 50	FC-System	FC-Systems Performance Test Codes	2002	Test procedures, methods and definitions for the performance characterization of fuel cell power systems	+
Standard	GB/T	Chinese National Standard	GB/T 23645	FC-System	Test method of fuel cell power system for passenger car	2009		-
Standard	GB/T	Chinese National Standard	GB/T 25319	FC-System	Fuel Cell test system used for motor vehicles - Technical specification	2010		-
Standard	GB/T	Chinese National Standard	GB/T 28183	FC-System	Test methods of fuel cell power system for bus	2011		-
Standard	GB/T	Chinese National Standard	GB/T 33978	FC-System	Proton exchange membrane fuel cell module for road vehicle	2017		-
Standard	GB/T	Chinese National Standard	GB/T 36288	FC-System	Fuel cell electric vehicle fuel cell stack safety requirements	2018		-

Table 8: Testing standards

Type	Publisher	Publisher	No.	Category	Title	Date	Content	VECTO relevance
Standard	SAE	SAE International	SAE J2615	FC-System	Testing Performance of Fuel Cell Systems for Automotive Application	Okt.11	Provides a framework for performance testing of FCS's designed for automotive applications. The procedures allow to measure the performance relative to manufacturerer claims.	+
Standard	SAE	SAE International	SAE J2594	FC-System	Recommended Practice to Design for Recycling Proton Exchange Membrane (PEM) Fuel Cell Systems	Nov.11	-	-
Standard	SAE	SAE International	SAE J2616	Fuel Processing System	Testing Performance of the Fuel Processor Subsystem of an Automotive Fuel Cell System	Aug.11	DVP - Test procedures, methods and definitions for the performance of the fuel processor subsystem (FPS) of a FCS are provided.	+
Standard	ISO	International Organization for Standardization	ISO 14687	Fuel Specifications	Hydrogen Fuel - Product Specification	Nov.19		-
Standard	NIST	National Institute of Standards and Technology USA	NIST 130 – 2020 IV	Fuel Specifications	Uniform Fuels and Automotive Lubricants Regulation-Retail Sales of Hydrogen Fuel Standard Specification	Mär.20		-
Standard	SAE	SAE International	SAE J2719	Fuel Specifications	Hydrogen Fuel Quality for Fuel Cell Vehicles	Mär.20	This standard provides background information and a hydrogen fuel quality standard for FCEV's. This report also provides background information on how this standard was developed by the Hydrogen Quality Task Force (HQTF) of the Interface Working Group (IWG) of the SAE Fuel Cell Standards Committee.	~
Standard	SAE	SAE International	SAE J3219	Fuel Specifications	Hydrogen Fuel Quality Screening Test of Chemicals for Fuel Vehicles	Mär.20		-

Table 8: Testing standards

Type	Publisher	Publisher	No.	Category	Title	Date	Content	VECTO relevance
Standard	DIN	Deutsches Institut für Normung	DIN EN 17124	Fuel Specifications	Wasserstoff als Kraftstoff - Produktfestlegung und Qualitätssicherung - Protonenaustauschmembran(PEM)-Brennstoffzellenanwendungen für Straßenfahrzeuge	Jul.19	Dieses Dokument spezifiziert Wasserstoff als Kraftstoff zum Betrieb von Straßenfahrzeugen mit PEM-Brennstoffzelle als Energiequelle für die Elektromotoren zum Antrieb des Fahrzeugs. Aufgrund der besonderen Empfindlichkeit dieser Antriebssysteme wird auch die Qualitätssicherung des Kraftstoffs Wasserstoff in Bezug auf dessen Reinheit in diesem Dokument besonders betrachtet.	-
Technical Report	SAE	SAE International	SAE J3089	H2 Sensors	Characterization of On-Board Vehicular Hydrogen Sensors	Oct 2018	-	-
Standard		Compressed Gas Association	CGA PS31	Hydrogen Storage System	Cleanliness for PEM Hydrogen Piping / Components	2019		-
Standard	ISO	International Organization for Standardization	ISO 12619	Hydrogen Storage System	Compressed gaseous hydrogen and hydrogen/methane blends fuel components	2017		-
Standard	SAE	SAE International	SAE J2579	Hydrogen Storage System	Standard for Fuel Systems in Fuel Cell and Other Hydrogen Vehicles	Jun.18	The purpose of this document is to define design, construction, operational, and maintenance requirements for hydrogen fuel storage and handling systems in on-road vehicles.	~
Standard	SAE	SAE International	SAE J2760	Hydrogen Storage System	Pressure Terminology Used In Fuel Cells and Other Hydrogen Vehicle Applications	Jun.11	Definitions for pressurized systems and containers were developed. The purpose of this document is to disseminate these definitions prior to the release of SAE J2579 such that other technical groups are aware of the information	~
Standard		Deutsches Institut für Normung	DIN EN 13018	Others	Non-destructive testing – Visual testing – General principles	2015		~
Standard	ISO	International Organization for Standardization	EN ISO/IEC 17025	Others	General requirements for the competence of testing and calibration laboratories	2005		~
Standard	JCGM	Joint Committee for Guides in Metrology	JCGM 100	Statistics	Evaluation of measurement data – Guide to the expression of uncertainty in measurement	2008		-

Table 8: Testing standards

Type	Publisher	Publisher	No.	Category	Title	Date	Content	VECTO relevance
Standard	IEC	International Electrotechnical Commission	IEC/TS 62282-1	Terminology	Fuel cell technologies – Part 1: Terminology	Apr 2010		~
Standard	JIS	Japanese Standards Association	JIS C 8800	Terminology	Glossary Of Terms For Fuel Cell Power System	Jan 2000 (2008)		-
Standard	SAE	SAE International	SAE J2574	Terminology	Fuel Cell Vehicle Terminology	Sep.11	Contains definitions for FCEV terminology.	~
Regulation	EU	European Union	EU 406/2010	Vehicle	Implementation of Regulation (EC) No 79/2009 of the European Parliament and of the Council on type-approval of hydrogen-powered motor vehicles	Apr.10		~
Regulation	UNECE	United Nations Economic Commission for Europe	UNECE GTR 113	Vehicle	Global technical regulation on hydrogen and fuel cell vehicles	Jul.13		~
Regulation	UNECE	United Nations Economic Commission for Europe	UNECE R 134	Vehicle	Uniform provisions concerning the approval of motor vehicles and their components with regard to the safetyrelated performance of hydrogen-fuelled vehicles (HFCV)	Jun.15		~
Standard	ISO	International Organization for Standardization	ISO 23828	Vehicle Performance	Fuel Cell Road Vehicle- Energy Consumption Measurement	2013	This International Standard specifies the procedures for measuring the energy consumption of fuel cell passenger cars and light-duty trucks that use compressed hydrogen and which are not externally chargeable.	~
Standard	ISO	International Organization for Standardization	ISO/TR 11954	Vehicle Performance	Fuel Cell Road Vehicles- Road Maximum Speed Measurement	2008	Describes test procedures for measuring the maximum road speed of fuel cell passenger cars and light duty trucks which use compressed hydrogen and which are not externally chargeable, in accordance with national or regional standards or legal requirements.	~

Table 8: Testing standards

Type	Publisher	Publisher	No.	Category	Title	Date	Content	VECTO relevance
Standard	SAE	SAE International	SAE J2572	Vehicle Performance	Recommended Practice for Measuring Fuel Consumption and Range of Fuel Cell and Hybrid Fuel Cell Vehicles Fuelled by Compressed Gaseous Hydrogen	Okt.14	Establishes uniform procedures for testing FCEV's. Provides standard tests for the determination of fuel consumption and range based on the US Federal Emission Test Procedures using UDDS and HFEDS.	+
Standard	CNS	Chinese National Standard	CNS 15499	Vehicle Safety	Electrically propelled road vehicles – Safety specifications	2011		-
Standard	IEC	International Electrotechnical Commission	IEC 62282-2	FC-System	Fuel cell technologies - Part 2-100: Fuel cell modules - Safety (IEC 105/683/CDV:2018)	Feb.19	This part of the IEC 62282 series specifies the requirements for the design, operation under normal and abnormal conditions and testing of fuel cell modules.	+
Standard	ISO	International Organization for Standardization	ISO 23273	Vehicle Safety	Fuel Cell Road Vehicle – Safety specifications - Protection against hydrogen hazards for vehicles fueled with compressed hydrogen	2013	This International Standard specifies the essential requirements for fuel cell vehicles (FCV) with respect to the protection of persons and the environment inside and outside the vehicle against hydrogenrelated hazards.	-
Standard	ISO	International Organization for Standardization	ISO 6469-3	Vehicle Safety	Electrically propelled road vehicles – Safety specifications	2019	Specifies requirements for the electric propulsion systems and conductively connected auxiliary electric systems, if any, of electrically propelled road vehicles for the protection of persons inside and outside the vehicle against electric shock.	-
Standard	SAE	SAE International	SAE J1766	Vehicle Safety	Recommended Practice for Electric and Hybrid Electric Vehicle Battery Systems Crash Integrity Testing	2014	This SAE Recommended Practice is applicable to Electric, Fuel Cell and Hybrid vehicle designs that are comprised of at least one vehicle propulsion voltage bus with a nominal operating voltage greater than 60 and less than 1,500 VDC, or greater than 30 and less than 1,000 VAC. This Recommended Practice addresses post-crash electrical safety, retention of electrical propulsion components and electrolyte spillage.	-
Standard	SAE	SAE International	SAE J2578	Vehicle Safety	Recommended Practice for General Fuel Cell Vehicle Safety	2009	This SAE Recommended Practice identifies and defines the preferred technical guidelines relating to the safe integration of fuel cell system, the	-

Table 8: Testing standards

Type	Publisher	Publisher	No.	Category	Title	Date	Content	VECTO relevance
							hydrogen fuel storage and handling systems as defined and specified in SAE J2579, and electrical systems into the overall Fuel Cell Vehicle. This document relates to the overall design, construction, operation and maintenance of fuel cell vehicles.	
Standard	SAE	SAE International	SAE J2990/1	Vehicle Safety	Hydrogen and Fuel Cell Vehicle First and Second Responder Recommended Practice	2016	The electrical hazards associated with the high voltage systems of hybrid-electric vehicles and FCVs are already addressed in the parent document, SAE J2990. This Recommended Practice therefore addresses electric issues by reference to SAE J2990 and supplements SAE J2990 to address the potential consequences associated with hydrogen vehicle incidents and suggest common procedures to help protect emergency responders, tow and/or recovery, storage, repair, and salvage personnel after an incident has occurred. Industry design standards and tools were studied and where appropriate, suggested for responsible organizations to implement.	-
Standard	ISO	International Organization for Standardization	ISO TR 15916		Basic considerations for the safety of hydrogen systems			-
Standard	ISO	International Organization for Standardization	ISO 17268		Gaseous hydrogen land vehicle refuelling connection devices			-
Standard	SAE	SAE International	SAE J2799		Hydrogen Surface Vehicle to Station Communications Hardware and Software			-
Standard	SAE	SAE International	SAE J2578		Recommended Practice for General Fuel Cell Vehicle Safety			-
Standard	SAE	SAE International	SAE J2601		Fueling Protocols for Light Duty and Medium Duty Gaseous Hydrogen Surface Vehicles			-

Table 8: Testing standards

Type	Publisher	Publisher	No.	Category	Title	Date	Content	VECTO relevance
Standard	SAE	SAE International	SAE J2600		Compressed Hydrogen Surface Vehicle Fueling Connection Devices			-
Standard	SAE	SAE International	SAE J2990		Gaseous Hydrogen and Fuel Cell Vehicle First and Second Responder Recommended Practice			-
Regulation	EU	European Union	EU 79/2009	Vehicle	Type-approval of hydrogen-powered motor vehicles			-

The analysis of the standards indicates suitable and transferable test procedures for VECTO-relevant HDV measurements. Standards that are marked with a "+" and thus achieve the highest level of agreement:

- ASME PTC 50: FC-Systems Performance Test Codes
- SAE J2615: Testing Performance of Fuel Cell Systems for Automotive Application
- SAE J2616: Testing Performance of the Fuel Processor Subsystem of an Automotive Fuel Cell System
- SAE J2572: Recommended Practice for Measuring Fuel Consumption and Range of Fuel Cell and Hybrid Fuel Cell Vehicles Fuelled by Compressed Gaseous Hydrogen
- IEC 62282-2: Fuel cell technologies – Part 2-100: Fuel cell modules – Safety (IEC 105/683/CDV:2018)

Based on these standards, test procedures for FC systems, subsystems and components are developed. In addition to the application-specific boundary conditions of the test standards, special emphasis must be placed on the reproducibility of the measurements, especially for FC Systems and FC Stacks. Stable conditions during the certification test to ascertain the FCS power consumption map is crucial. Standard approach to determine stable operation of the FC-stack is the monitoring of the standard deviation of either the stack current or the stack voltage [23].

This approach applicable for research on fuel cell stacks is complicated for the system characterization required by VECTO for two reasons: The stack terminals, to measure the stack voltage on each individual stack inside a system, are difficult to access on a series production system and the dense layout of the total system might avoid the installation of an independent current sensor. Therefore, the approach envisaged for VECTO is treating the system as a black box with reproducible operation characteristics where only the fuel consumption and the net power-output are monitored. To reduce the testing time, a stability criterion is proposed to step through the operation points up and down, from minimum to maximum FCS output power. Further details are provided in section 3.2.2.

3.2.1.2 Possible fuel cell vehicle powertrain configurations and its implications for VECTO

At fuel cell vehicles (FCV) energy conversion and energy storage are separated, i.e. the FC is the energy converter and the hydrogen tank the energy storage, which allows for a higher energy stored on-board and therefore higher driving range and faster refuelling compared to Pure Electric Vehicles (PEVs). FC propulsion systems are seen as the "long distance" alternative to existing PEV propulsion systems.

For actual use as a vehicle propulsion system, only the Fuel Cell Hybrid Vehicle (FCHV) configuration comes into question. The powertrain of a FCHV basically consists of hydrogen storage system (energy storage), fuel cell system (energy converter), battery system (energy storage and converter), various voltage transformers (converters and inverters), electric motor(s), gear box and mechanical drive to the wheels. Basically, FCHV are classified into two main concepts:

- the fuel cell dominant concept
- the range extender (REX) concept.

Moreover, intermediate concepts of these are possible, which are usually mentioned as “mid-size fuel cell” layouts.

In the dominant fuel cell drive, see Figure 30, the driving power is supplied by the fuel cell, and the battery is used exclusively for recuperation of braking energy during deceleration and power assistance during acceleration. In passenger cars, the fuel cell is therefore quite powerful (100 to 150 kW), the battery is usually of high power density and low capacity (1 to 2 kWh), and the hydrogen tank is a high-pressure tank containing several kilograms of H₂ (5 to 6 kg) to achieve ranges of up to 600 km. Energy is supplied by refueling with hydrogen. [5]

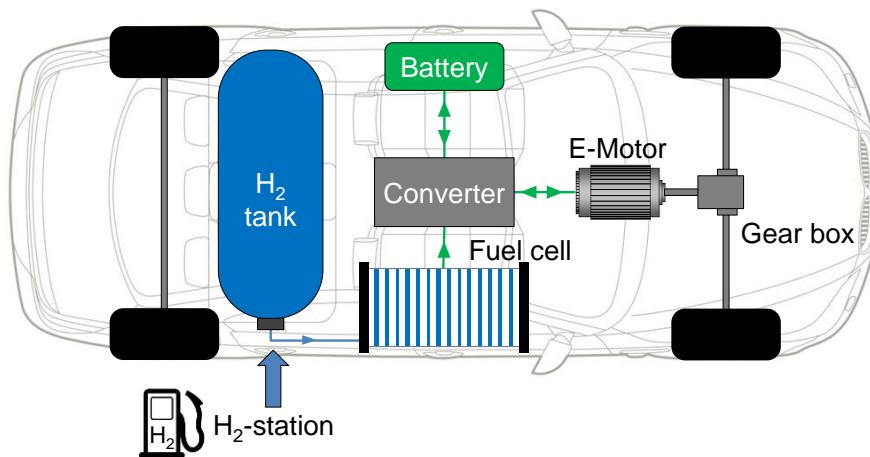

Figure 30: Fuel cell dominant powertrain concept [5]

In the range extender drive, see Figure 31, the driving power requirement is supplied by the battery, and the fuel cell is used to charge the battery while driving, thus extending the range of the vehicle. Range extender passenger cars usually feature a lower power density high capacity battery, a low power (20 to 30 kW) fuel cell, and a small volume pressurized hydrogen tank. In the case of range extender drives, the larger battery means that the vehicle can be designed as a plug-in, i.e. in addition to hydrogen refueling, the vehicle's energy supply is provided by charging the battery via the power grid.

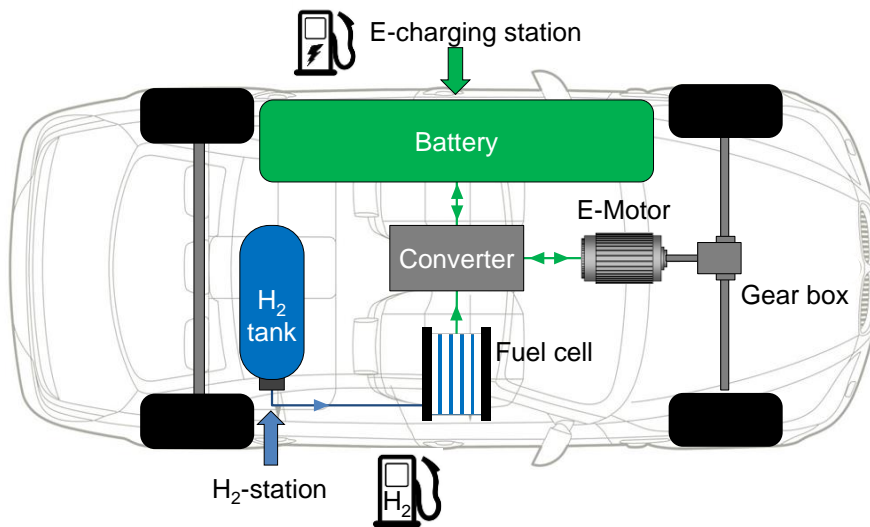

Figure 31: Fuel cell range extender concept [5]

In addition to these boundary concepts, all configurations in the range between REX and fuel-cell dominant propulsion are often named as mid-size concepts.

Most truck models announced by vehicle manufacturers for Europe so far comply with this mid-size concept, see Table 9. In such a concept the battery also has the function as a buffer for the electric energy provided by the FC, in order to phlegmatise the operation of the latter. For buses, there are also FCHV REX models announced, in which the FC serves as a range extender for battery-electric operation as described above.

Table 9: Selected hydrogen electric truck models in Europe (source: [24])

Maker-model	Type	Fuel cell power	Battery size	E-drive power ^{a)}	H ₂ tank size and technology	Range ^{f)}
Hyundai-Xcient ^{b)}	4	190 kW	72 kWh	350 kW	31 kg - 350 bars	400 km
Daimler-GenH ₂ ^{c)}	4/5/9/10	300 kW	70 kWh	460 kW	80 kg - Liquid	1,000 km
DAF-VDL ^{d)}	5	60 kW	85 kWh	-	40 kg - 350 bars	350 km
DAF-VDL ^{d)}	9	60 kW	82 kWh	-	40 kg - 350 bars	400 km
MAN ^{d)}	4	100 kW	120 kWh	-	34 kg - 350 bars	400 km
Scania ^{e)}	9	90 kW	56 kWh	210 kW	33 kg - 350 bars	500 km

a) Continuous power

b) Hyundai (2021)

c) Daimler (2021)

d) FCH JU & Roland Berger (2020)

e) Scania (2020)

f) Driving range reported by the truck manufacturers under very specific driving and weather conditions.

Figure 32 shows generic fuel cell electric vehicle powertrain topologies suited for long-haul heavy-duty applications. Subsystems and power electronics DC/DC converters are added or removed depending on the nature of the application, expected duty cycle and lifespan, selected onboard

energy management and control strategies, product design and cost constraints [25]. Figure 33 indicates a possible topology layout for HDV application.

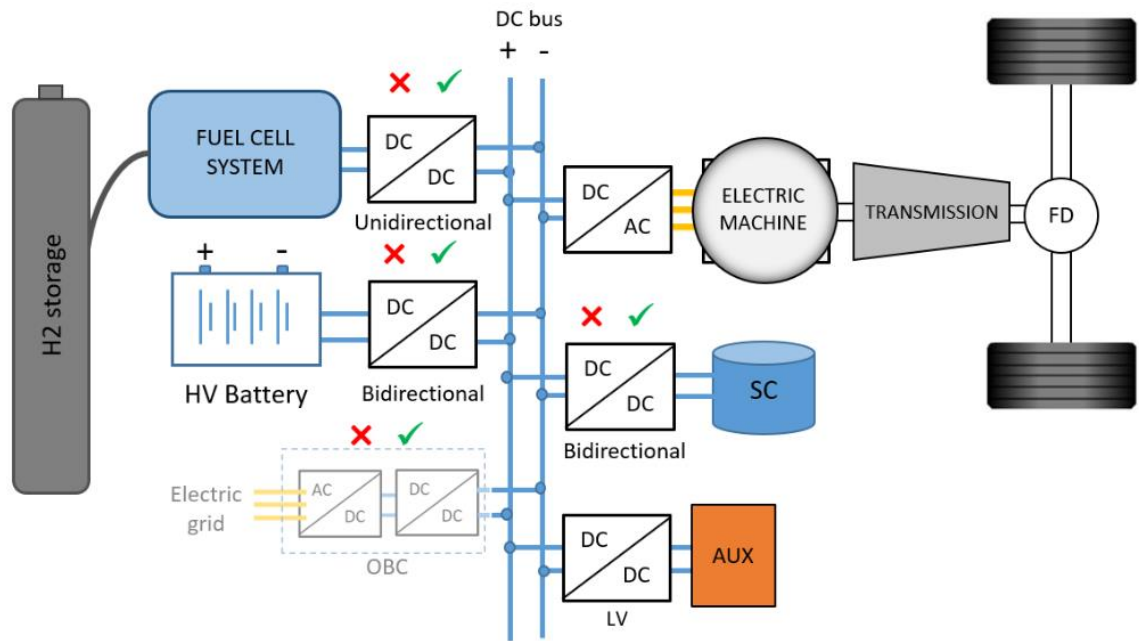

Figure 32: Generic FCHV powertrain topology

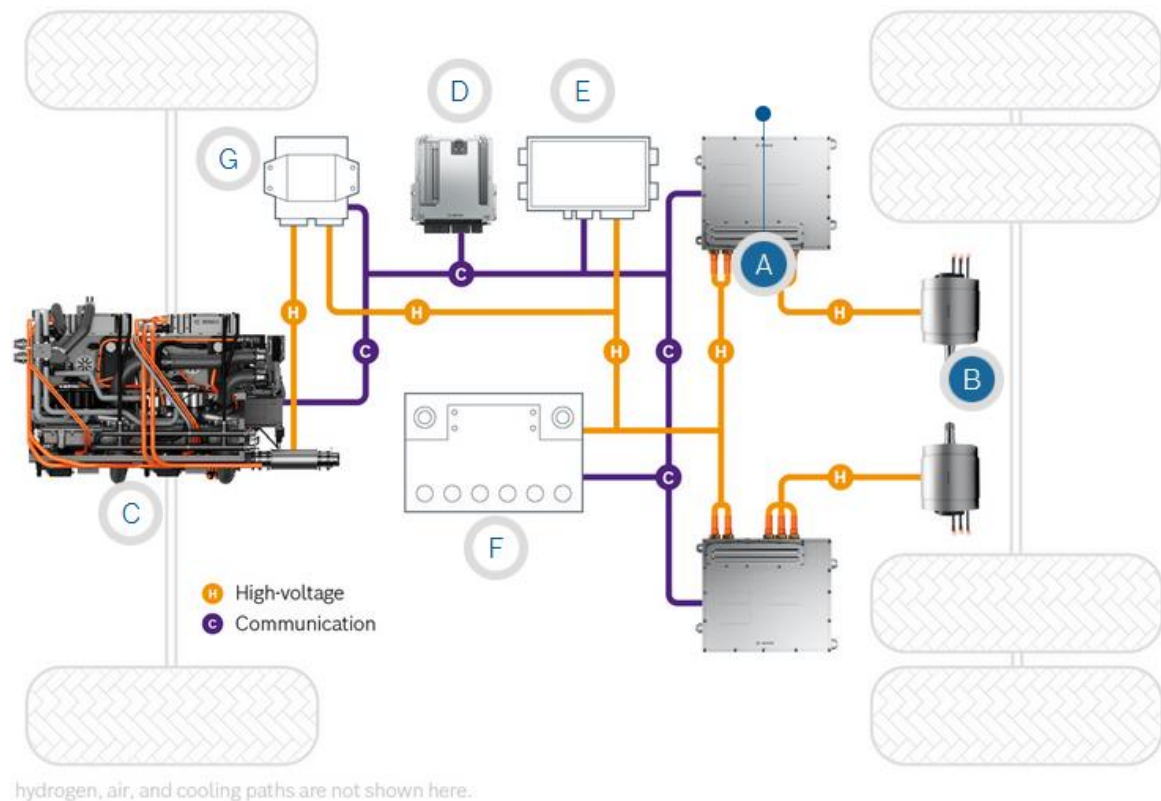

Figure 33: System overview FCHV [15]

This variability of possible FCHV configurations needs to be taken into account in VECTO and Regulation (EU) 2017/2400. In the implementation, it is possible to build fully on the already modular basic approach and in particular on the already scalable architecture of VECTO's xEV powertrain models. The elements to be specifically considered in the implementation for FCEV are described in Table 10.

Table 10: Requirements for VECTO to cover variable FCHV configurations

Element	Implementation
Configurability of various xEV powertrains architectures with various electrical energy sources (REESS, FCS).	<p>A free configurability is already provided by the existing xEV VECTO model architecture, i.e. all common purely electric powertrain architectures can be configured in VECTO and linked to a freely configurable battery subsystem package.</p> <p>In order to enable the simulation of FCHV, the fuel cell system (FCS)⁷ needs to be added as additional component to the powertrain builder.</p>
Number of FCS installed in the vehicle	In contrast to serial HEVs, where there is always only a single GEN-set in the vehicle configuration, the number of FCS must be freely configurable for FCHVs.
FCHV operation strategy	The generic operating strategy implemented for FCHV in VECTO must be able to handle all topologies (fuel-cell dominant up to REX) as well as multiple FCS.
Generic assumptions for vehicle operation (charge depleting mode "CD", charge sustaining mode "CS") depending on the configuration of the vehicle.	<p>The method already developed for OVC-HEVs to describe the different possible driving modes (CD, DS) is also suitable for FCHVs which do have an external charging feature for electric energy.</p> <p>The question is how the different FCHVs topologies (especially the fuel-cell dominant concept) will be operated by vehicle owners in the future, i.e. whether they apply also electric (intermediate) charging or only hydrogen refuelling. Corresponding assumptions need to be defined for VECTO if - as for OVC-HEV - a weighted result from CD and CS is to be calculated.</p> <p>Alternatively, for FCHV there would also be the option - at least until empirical values from operation are available - to only output the separate results for el. consumption in CD mode and the H2 consumption in CS mode, and not to calculate a weighted result.⁸</p>

The details of the concrete implementation in VECTO are described in section 3.2.3.

⁷ Fuel cell system (FCS) is the system as certified in the component test (see next section).

⁸ This option does not exist for OVC-HEV, as a weighted CO2 value needs to be determined for the CO2 standards.

3.2.2 Work package 2.2.2: Elaboration of a component testing procedure

In WP 2.2.2 a component test procedure was elaborated under the leadership of the project team and input as well as intensive exchange by the Task Force Fuel Cell System (TF-FCS). The elaborated document can serve as a well prepared basis for an extension of Annex Xb in the third amendment of Regulation (EU) 2017/2400.

The final draft document was elaborated within a total of 23 sessions of the TF-FCS, where 17 of those were dedicated to working on the component test procedure and the remaining 5 special sessions were used for working on topics related to FCS specific simulations methods in VECTO.

The next-to-final draft was distributed within the TF-FCS beginning of July 2023 for a final review. Any feedback received was – depending on the complexity level – either directly implemented into the final draft version supplied together with this report or documented on a list provided as separate document `Task2_FCS_Annex10b_ListFinalFeedback.docx`. In order to be able to take this feedback fully into account and to complete some methodological details mentioned below, the work was continued until October 2023 when analyses and proposals were developed for all elements. The final editorial work on the Annex will be completed under the umbrella of the Heavy Duty CO₂ Determination Group (HCDG).

In the following sub-chapters the most relevant elements of the elaborated component test procedure are summarized.

3.2.2.1 System boundary of the FCS

A typical FCS consists of several main sub-systems⁹ as depicted in Figure 34, which are required for supply of fuel or air, thermal management, (control) signal exchange as well as interface for the usable system output (i.e. electric power).

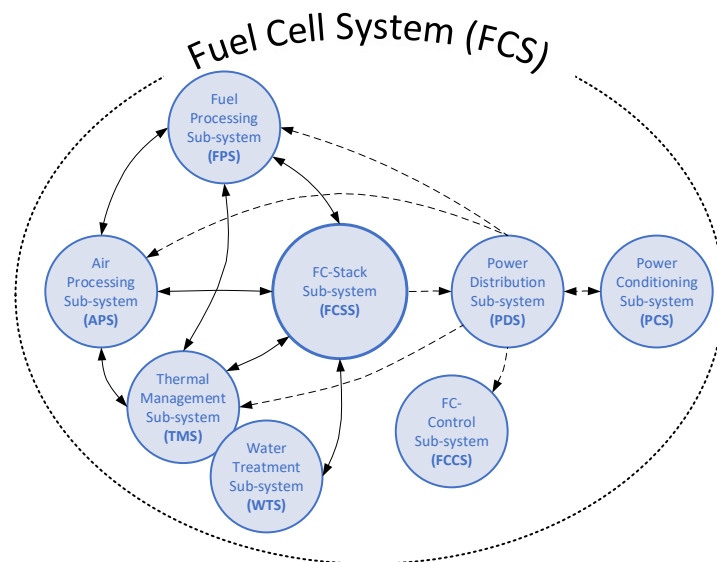

Figure 34: Fuel Cell System Sub-systems.

⁹ The terms and abbreviations of the FCS-sub-systems are adopted from the norm SAE J2615 OCT2011: "Testing Performance of Fuel Cell Systems for Automotive Applications"

The assembly of all the supporting components and auxiliary systems of a power plant needed to deliver the energy, other than the generating unit itself, are called Balance of Plant (BoP). Most of these sub-systems generate losses or even require a certain energy supply for their operation, which is typically provided either directly by the fuel cell itself or by the vehicle's power net. Thus, it is essential to exactly define the system boundary to be applied for the specific component test procedure which determines which of the sub-systems are part of the energetic balance and which are not considered. Clear rules and provisions for the system boundary were elaborated, which on the one hand define exactly all single elements that are considered relevant for the efficiency and thus have to be part of the unit under test and on the other hand allow for some flexibility in system arrangement. Figure 35 illustrates this definitions and the corresponding signal flows over the system boundaries graphically.

Furthermore, four different FCS topology types were defined to reflect the different cases of system interfaces between FCS supplier and vehicle integrator, which differ in their specific BoPC arrangement. The differences can occur in two relevant parameters, the pumps of the cooling system and the power conditioning system, leading to a total of four possible combinations. An overview of these four different topology types, the general handling of BoP elements for the component test as well as rules for substitution of certain vehicle specific elements by test cell equipment is given in Figure 36.

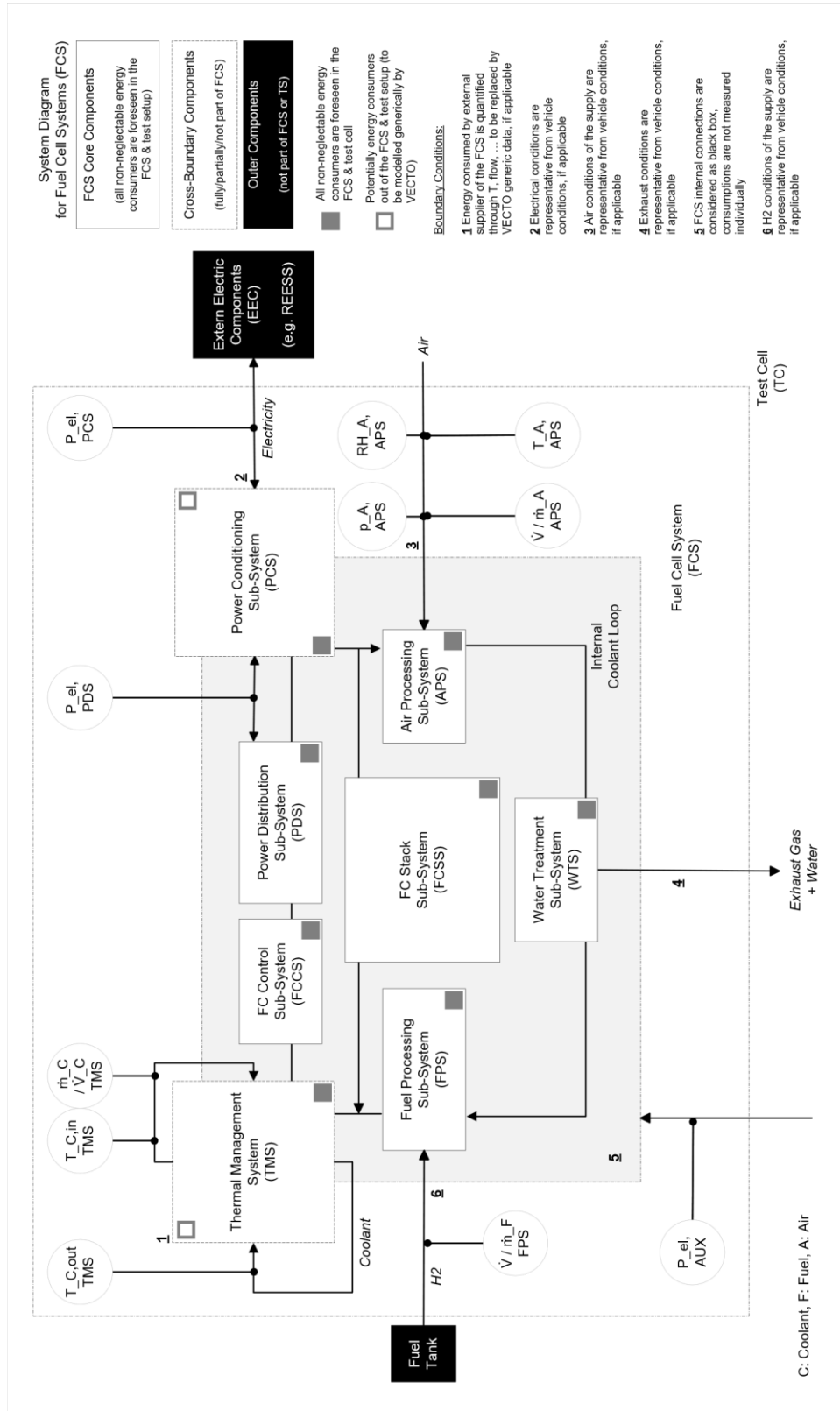

Figure 35: System boundary definition of FCS and respective signal flows

Sub-System (non binding assignment)	Component	Part of FCS				Fitted for certification test			
		Type A	Type B	Type C	Type D	Type A	Type B	Type C	Type D
APS (Air Processing Sub-system)	Inlet particle filter	No				Yes, or test cell equipment ^[2]			
	Inlet manifold	No				Yes, or test cell equipment ^[2]			
	Intake air charging equipment (e.g. el. Turbocharger or compressor)	Yes				Yes			
	Air flow meter ^[3]	Yes				Yes			
	Air inlet duct work	No				Yes, or test cell equipment ^[2]			
	Inlet silencer ^[3]	No				Yes, or test cell equipment ^[2]			
	Charge air cooler ^[3]	Yes				Yes			
TMS (Thermal Management Sub-System)	Humidification ^[3]	Yes				Yes			
	All coolant pump(s)	Yes	No, or partly			Yes	Yes, else test cell equipment ^{[1][2][5]}		
	Radiator	No				Test cell equipment ^[2]			
	Ion-Exchanger ^{[3][6]}	Yes				Yes, or test cell equipment ^{[2][3]}			
WTS (Water Treatment Sub-system)	Fan	No				No			
	Water separator ^[3]	Yes				Yes			
	Drain Valve ^{[3][6]}	Yes				Yes			
	Exhaust manifold	No				Yes, or test cell equipment ^[2]			
	Connecting pipes	No				Yes, or test cell equipment ^[2]			
	Silencer ^[3]	No				Yes, or test cell equipment ^[2]			
	Tail pipe	No				Yes, or test cell equipment ^[2]			
FPS (Fuel processing Sub-System)	Exhaust H2-Sensor	No				Yes, or test cell equipment ^[2]			
	Fuel Supply System (FSS)	No				Yes ^[2]			
	Pressure regulator / Injector	Yes				Yes			
	Fuel heat exchanger ^[3]	Yes				Yes			
	Active Recirculation device (Compressor/Pump) ^[3]	Yes				Yes			
	Passive Recirculation Device (Injector/Ejector) ^[3]	Yes				Yes			
FCSS (FC-Stack Sub-system)	Filters ^[3]	Yes				Yes			
	*	Yes				Yes			
PDS (Power Distribution Sub-System)	Electrical components (e.g. cables, switches, relays...)*	Yes				Yes ^[4]			
PCS (Power Conditioning Sub-System)	Voltage regulator (DC/DC) and/or converter (DC/AC)	Yes	No	Yes	No	Yes	Test cell equipment ^{[1][2]}	Yes	Test cell equipment ^{[1][2]}
FCCS (FC-Control Sub-System)	Processing/control unit	Yes				Yes			
	Software of specified version	Yes				Yes ^[4]			

* no further break-down

[1] not part of the certified energy balance, missing BoPC have to be handled separately (e.g. by generic value in VECTO)

[2] according to manufacturer specification which shall ensure real world like operation

[3] if applicable/mounted on FCS respectively vehicle

[4] only adaptations are allowed to enable standalone operation

[5] it might be that some items are integrated others not

[6] might be part either of TMS or WTS

Figure 36: Different topology types of FCS regarding BoPC configuration

3.2.2.2 Methodology of FCS component test

During the vehicle simulation in VECTO, for each timestep a certain electrical power demand is requested from the FCS. Thus, the information about the system characteristic required by VECTO – apart from some limitations in maximum power or system dynamics – is the resulting fuel consumption as function of the provided electric power output by the FCS.

Therefore, the certification test procedure in general aims at recording stationary data on fuel consumption and corresponding usable electric power output of a stabilized FCS at a suitable number of operation points to reflect the characteristics of the specific system. Each operating point is specified by its set-point for the electrical FCS power output in kW.

A stationary measurement of operation points without any additional testing efforts for consideration of dynamic system operation was assumed to be accurately enough for two main reasons:

- The power output of FCS is decoupled from the vehicle's propulsion power demand due to the fact that the battery is utilized as electric buffer to cover peak power demands or steep power transients.
- A member of the TF-FCS performed a specific test program which showed a deviation of less than 1% in the resulting fuel consumption between pure stationary testing compared with a real dynamically operated FCS (see section 3.2.4 for details).

The certification test range covers the whole span for real world operation as specified by the FCS manufacturer, with a minimum number of 12 individual operation points to be measured (see Figure 37 exemplarily). Furthermore, the sequence of these operation points in the test (from lowest to highest power and back down again in descending order) as well as the transition gradient and the maximum step size between two single points was defined (see Figure 38 exemplarily). These definitions increase the repeatability of test results by providing a well-defined procedure and by averaging of the resulting measurements for the ascending and descending paths.

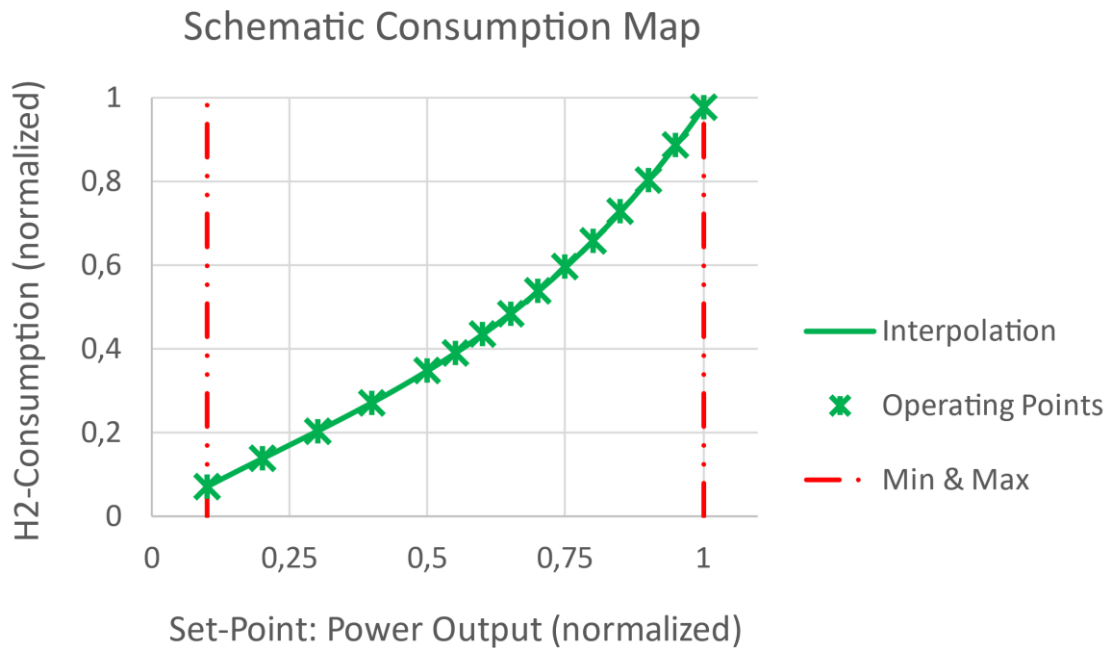

Figure 37: Range and location of operation points to be measured (exemplarily)

Scheme of Characterization Test

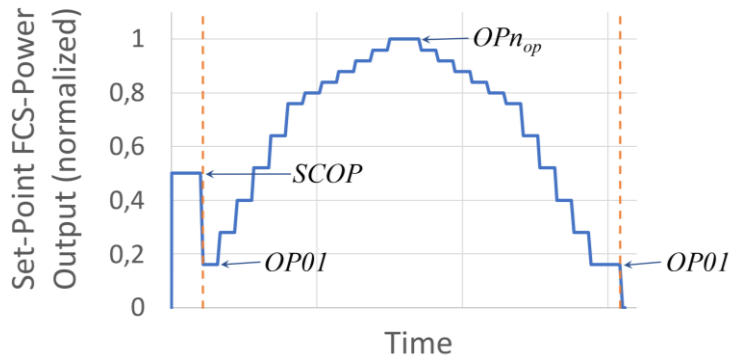

Figure 38: Sequence of operation points in component test

In order to assess if a stable system operation is reached at each measured operation point, criteria to define stability are required. Therefore, a defined stabilization phase with variable duration from 480 to a maximum of 1800 seconds was defined at each operation point which is followed by an analysis phase where the actual signals to be measured are recorded. During this analysis phase, the indicators for stability have to fulfil the defined limits which in turn allows a certain flexibility for the duration of the stabilization phase. Meaning, once the monitored signals have stabilized, the actual analysis phase can start. Figure 39 **Fehler! Verweisquelle konnte nicht gefunden werden.** illustrates these separate phases at each operation point graphically.

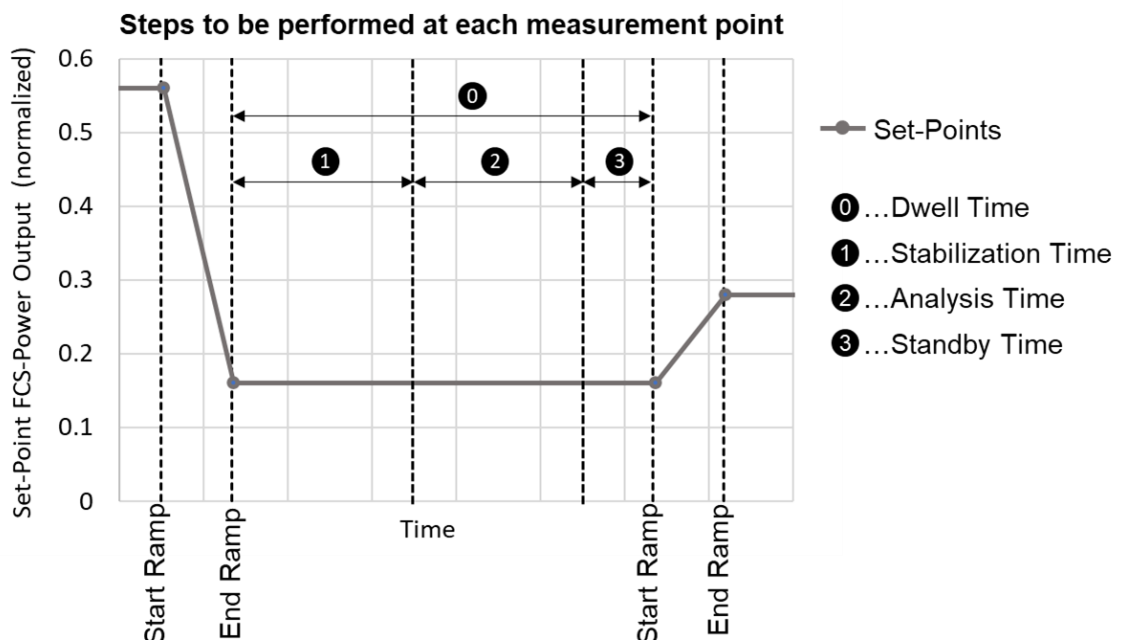

Figure 39: Stabilization time and analysis period at each operation point

As applicable stability criteria the following two indicators were defined:

- Absolute Value of the Relative Slope of the Estimate (ARS)
 - The ARS is calculated as absolute value of the quotient of the slope of the regression line divided by the arithmetic mean value of the test variable.
 - The limit is designed in a way that the signal does not show a certain trend over time but only small fluctuations around its arithmetic mean value are allowed.
- Relative Error of Estimate (REE)
 - The REE is calculated as absolute value of the quotient of the standard error of the estimate divided by the arithmetic mean value of the test variable.
 - This indicator limits the average deviations of the individual values of the signal from the regression line of the test variable.

During the analysis phase, both the electric output and the fuel mass flow signals have to fulfil the defined limits for ARS and REE. In order to take the accuracy behaviour of typical measurement equipment into account, functions were defined for both stability indicators reflecting that higher deviations are allowed at lower absolute values of the recorded signal. Figure 40 and Figure 41 illustrate the applicable limit functions and the corresponding parameters for ARS and REE, respectively. The exact numerical values for these limit functions were still under discussion at the time this document was compiled and will be finalized in further meetings of the taskforce for FCS under the umbrella of the HCDG.

The ARS_{limit} function is given by:

$$ARS_{limit} = \frac{1}{\frac{sc}{e^{sf \cdot P}} + 1} \cdot (l_u - l_l) + l_l$$

With:

$$P = [0, 1]$$

$$sc = 0.3$$

$$sf = 0.0457$$

$$l_u = 50 \cdot 10^{-6}$$

$$l_l = 15 \cdot 10^{-6}$$

P ... normalized FCS Power

sc ... step center

sf ... shape factor

l_u ... upper limit

l_l ... lower limit

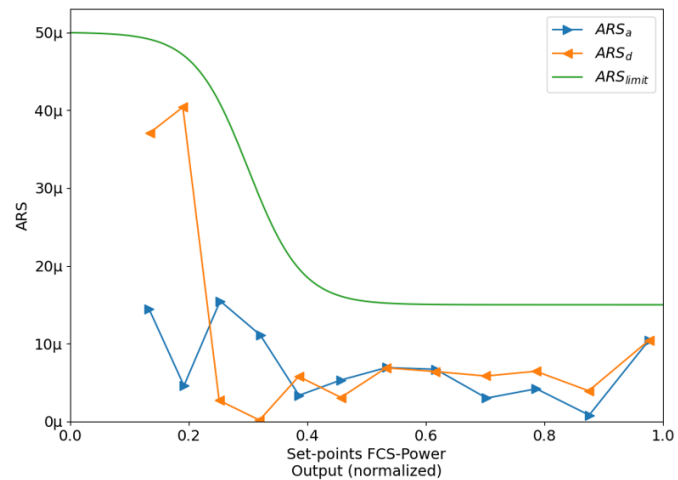

Figure 40: ARS limit function (exemplarily for fuel mass flow)

The REE_{limit} function is given by:

$$REE_{limit} = a \cdot P^{-b} + c$$

With:

$$P = [0, 1]$$

$$a = 1.23$$

$$b = 0.482$$

$$c = -0.75$$

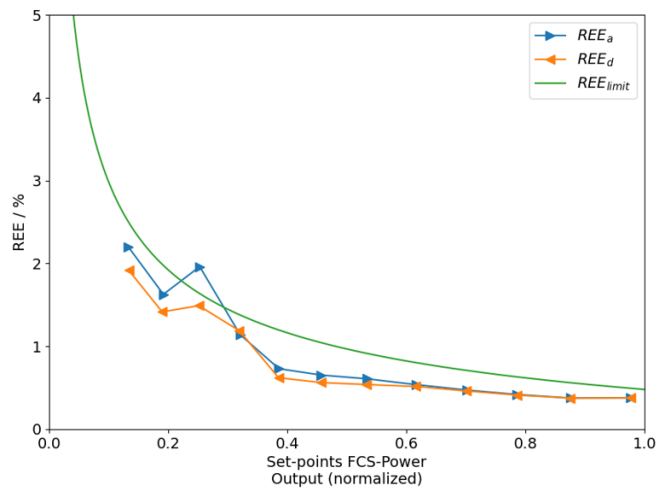

Figure 41: REE limit function (exemplarily for fuel mass flow)

The actual values for electric power output and fuel consumption for each set-point are then determined as the arithmetic mean over a case specific averaging period at the end of each operation point where system stability is ensured.

3.2.2.3 Corrections of FCS electric output

For the different FCS variants some flexibility in testbed setup regarding the arrangement of BoPC is allowed as explained in section 3.2.2.1. In case of such BoPC not being part of the actual unit under test or not installed within the unit under test (e.g. test cell equipment instead of vehicle specific equipment used) or being externally powered by the testbed infrastructure, their additional energy demand needs to be considered by correcting the measured electrical power output of the FCS accordingly.

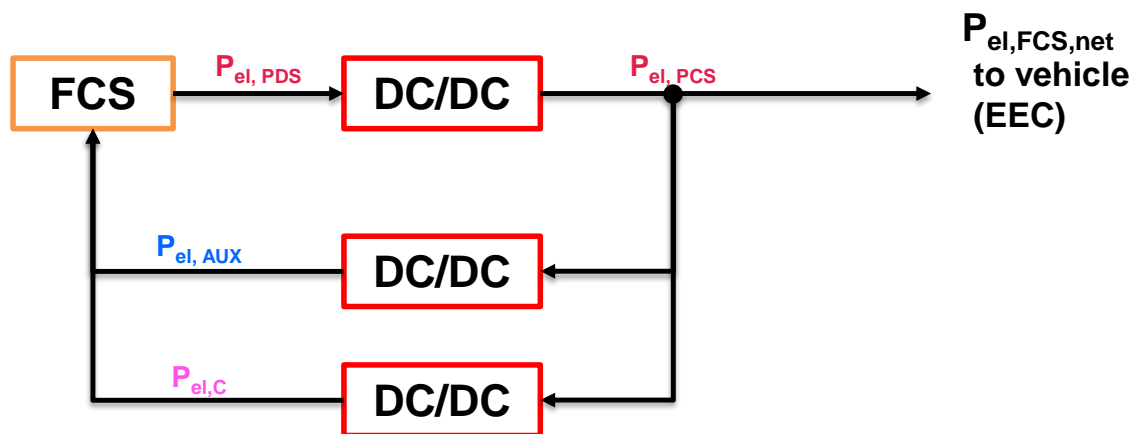

Figure 42: Generic reference points and signals for correction of FCS electric output

The following definitions and equations explain the corresponding corrections to be performed in detail:

In case the PCS not being part of the FCS installed for the certification test, the measured electrical power output at the location PDS in accordance with Figure 42 is corrected for the losses of a generic PCS in accordance with the following equation:

$$P_{el,PCS} = P_{FCS,PDS}^* \times \eta_{DC/DC}$$

where:

$P_{el,PCS}$	electrical power output at the location PCS in accordance with Figure 42 in kW
$P_{FCS,PDS}$	electrical power output of fuel cell system at the location PDS in accordance with Figure 42 in kW
$\eta_{DC/DC}$	generic efficiency factor of DC/DC converter of 0.975

For each coolant pump not installed for the certification test at all or not installed within the unit under test the electrical power uptake is calculated in accordance with the following equation:

$$P_{el,Cool} = (p_{C,TMS,in} - p_{C,TMS,out}) \times \dot{V}_{C,TMS,in} / \eta_{WP,hyd} / \eta_{WP,EM}$$

where:

$P_{el,Cool}$	electrical power uptake of the coolant pump in kW
$p_{C,TMS,in}$	pressure of the coolant upstream of the TMS in kPa
$p_{C,TMS,out}$	pressure of the coolant downstream of the TMS in kPa
$\dot{V}_{C,TMS,in}$	volumetric coolant flow upstream of the TMS in m ³ /s
$\eta_{WP,hyd}$	generic hydraulic efficiency factor of pump of 0.8
$\eta_{WP,EM}$	generic efficiency factor of electric pump drive of 0.8

The final effective electrical power output of FCS (used as input to the simulation tool) taking all components consuming additional electric power into account is calculated in accordance with the following equation:

$$P_{el,FCS,net} = P_{el,PCS} + \sum_{i=1}^n P_{el,AUX,i} / \eta_{DC/DC} + \sum_{j=1}^o P_{el,AUX,j} + \sum_{k=1}^p P_{el,Cool,k} / \eta_{DC/DC} + \sum_{l=1}^q P_{el,Cool,l}$$

$P_{el,FCS,net}$	effective electrical power output of FCS (used as input to the simulation tool) in kW
$P_{el,PCS}$	electrical power output at the location PCS in accordance with Figure 42 in kW
$P_{el,AUX}$	electrical power uptake of balance of plant component not installed for the certification test at all or not installed within the UUT or being externally powered by the testbed infrastructure during the certification test in kW

where the following differentiation is applied:

$P_{el,AUX,i}$	all components connected to the FCS either at the location PDS in accordance with Figure 42 or via a separate DC/DC converter; where $i = 1, 2, 3, \dots$ maximum number n of such components to be considered
$P_{el,AUX,j}$	all components connected to the FCS either at the location PCS in accordance with Figure 42 or without a separate DC/DC converter; where $j = 1, 2, 3, \dots$ maximum number o of such components to be considered
$P_{el,Cool}$	electrical power uptake of the coolant pump in kW where the following differentiation is applied:
$P_{el,Cool,k}$	all coolant pumps connected to the FCS either at the location PDS in accordance with Figure 42 or via a separate DC/DC converter; where $k = 1, 2, 3, \dots$ maximum number p of such components to be considered
$P_{el,Cool,l}$	all coolant pumps connected to the FCS either at the location PCS in accordance with Figure 42 or without a separate DC/DC converter; where $l = 1, 2, 3, \dots$ maximum number q of such components to be considered
$\eta_{DC/DC}$	generic efficiency factor of DC/DC converter of 0.975

In addition to corrections regarding the electric output power of the system depending on the arrangement of BoPC as described above, also the influence of intake air conditions on the system performance was analysed. Based on this analysis, the intake air pressure was identified as only significant influence parameter on the efficiency of the FCS. Background to Figure 43 is the fact that a lower ambient pressure level requires an increased compression ratio to achieve the required pressure at the stack inlet. Furthermore in the lower FCS load range the compressor power based on the necessary stack inlet pressure is dominant in comparison to the stack power. Hence, the efficiency deviation in low and idle load (10 and 20%) is higher. This trend reverses again from the medium load range onwards.

In order to consider this effect in the component certification where a certain range of the intake air pressure (roughly 0.9-1.0 bar) is allowed, a correction method based on a linear correlation of the deviation in system efficiency and the deviation from a reference air pressure will be defined for different normalized system loads based on the data derived by the basic analysis performed.

The methodologies for both corrections were agreed within the taskforce, but the exact numerical values for all generic efficiencies as well as the parameters and structure of the intake air pressure correction were still under discussion at the time this document was compiled and will be finalized in further meetings of the taskforce for FCS under the umbrella of the HCDG.

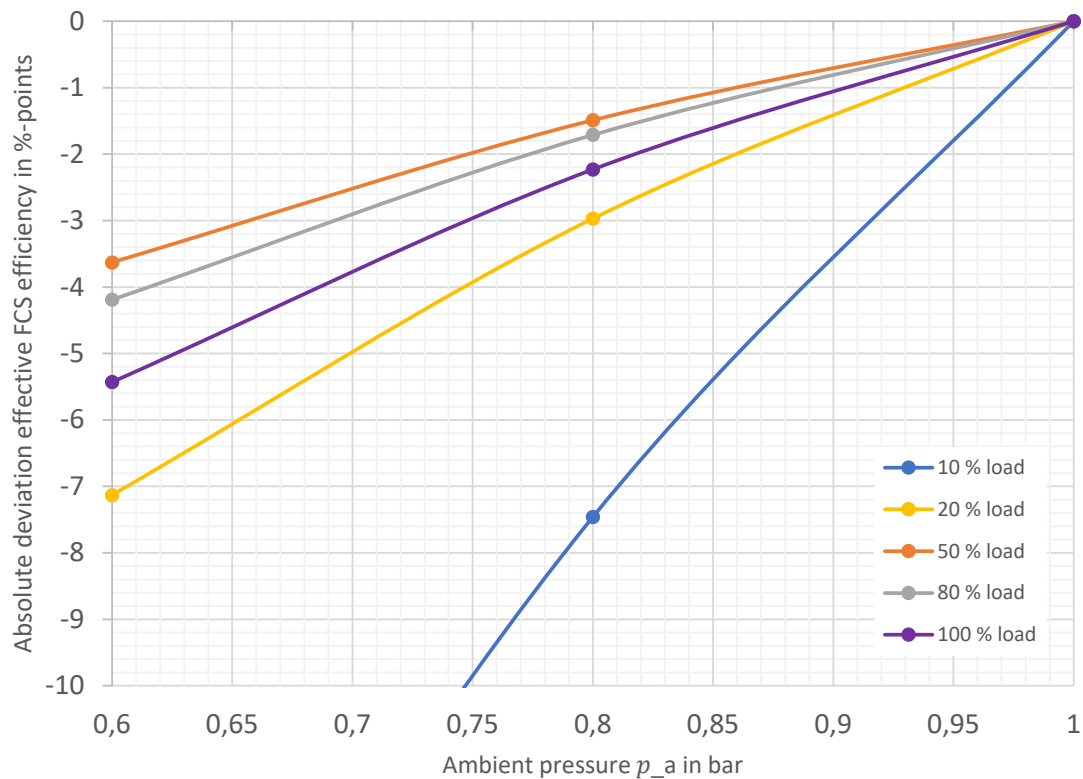

Figure 43: Influence of intake air pressure on system efficiency

3.2.2.4 Further elements of FCS component test

Apart from the actual component test procedure, several required standard elements of Regulation (EU) 2017/2400 were elaborated and are summarized in this section.

In Appendix 7 the contents of the **information document** were elaborated providing extensive documentation of the relevant system characteristics. Three specific attachments to the information document ensure the documentation of all relevant boundary conditions of the specific test performed or of the individual operation points measured in order to allow reproducibility (e.g. ambient conditions, cooling media characteristics, target values for operation points, set points for power electronics, transition slope between operation points, cooling flows and temperatures etc.)

In Appendix 11 **standard values** for FCS were defined to be applicable as fall back values in case the manufacturer decides not to undertake the full measurement effort. The data in this Appendix is defined as normalized fuel consumption curve as function of electric output power. The basic assumptions for the underlying system efficiency curve were presented in the last meeting of the taskforce in October 2023 and are shown in Figure 44. The exact numerical values as well as the approach for deducting a certain (constant or variable) amount in system efficiency were still under discussion at the time this document was compiled and will be finalized in further meetings of the taskforce for FCS under the umbrella of the HCDG.

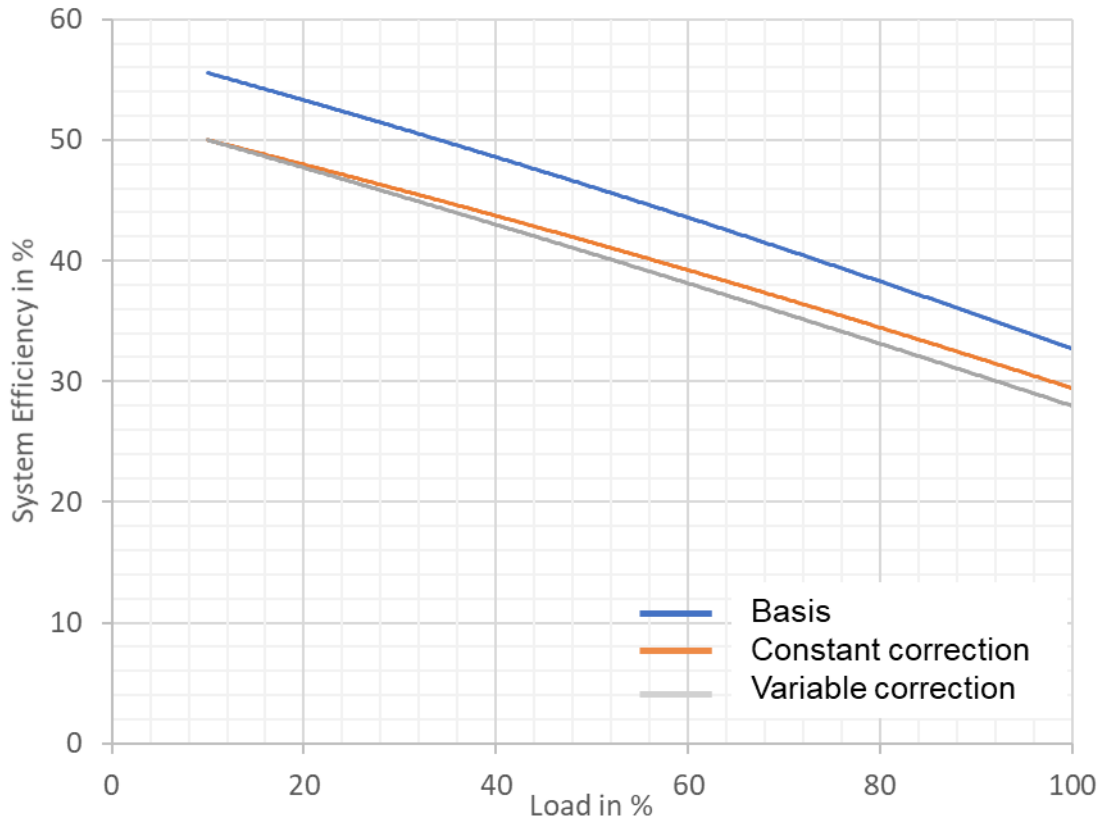

Figure 44: Basic approach for standard values

In Appendix 12 the provisions for **Conformity of Production (CoP)** testing were defined including the basic boundary conditions of the test and the yearly sample size. The basic option is to repeat the whole certification test and perform an averaging over all single points as basis for comparison with the originally certified efficiency. The experts in the TF suggested the elaboration of a testing method with reduced effort where the principles could be based on already existing methods for electric machines in Annex Xb. In more detail, this would mean a reduced amount of points to be tested and that sensors with lower accuracy would be allowed in production environment, where the excessive part of inaccuracy as compared to the original component certification would be counted as additional losses for the efficiency figure determined in the CoP test. The final values for sample size and pass/fail criteria were still under discussion at the time this document was compiled and will be finalized in further meetings of the taskforce for FCS under the umbrella of the HCDG. Also the enhanced concept allowing lower testing effort and less accurate sensors will be implemented during the final sessions held under the HCDG.

In Appendix 13 the provisions for the **family concept** were elaborated with two different levels specifying whether a specific FCS may be allocated to a certain FCS-family:

- A list of criteria that need to be the same for all members within a FCS-family
- A list of criteria that need to be common to all members within a FCS-family

Here the application of a specific range for deviations from the base value is defined for each parameter. This allows for a more flexible definition of families where certain elements with a negligible effect on system efficiency are allowed to change.

In Appendix 15 the specifications for the **input data to VECTO** were elaborated defining the data format, corresponding unit and number of significant digits as well as references to specific paragraphs of the Annex. Apart from the usual meta data about the component (e.g. manufacturer, model, certification method), the important input data are:

- Characteristic consumption curve of the FCS (i.e. fuel consumption as function of effective electric output power)
- Declared minimum supply pressure required by the FCS which affects the relevant lower limit for determining the usable mass of hydrogen from the vehicle's tank system

3.2.2.5 Consideration of the relevance of FCS ageing

Numerous processes lead to the ageing (degradation) of fuel cells during operation. As the number of load cycles increases, aging increases and the cell voltage decreases, see Figure 45. The voltage losses as a result of aging are composed of a reversible and irreversible component. Structural changes in the electrodes are usually mainly responsible for the degradation. In polymer electrolyte membrane fuel cells, electrode degradation is mainly caused by platinum dissolution and corrosion of the carbon carrier. For a more detailed description of degradation processes and analysis methods such as impedance spectroscopy in fuel cells, please refer to the technical literature [26] [27] [28] [29] [30].

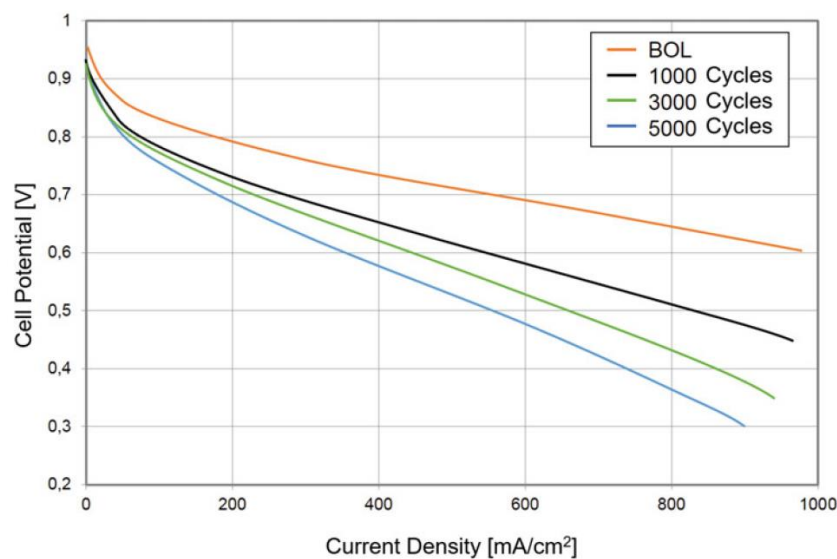

Figure 45: Effects of degradation on the UI curve [31]

Due to its efficiency, fast response times, compactness and high maturity, the PEM fuel cell (PEMFC) is the leading technology in most areas of application. Especially in vehicles, the operating conditions differ within a wide range, from relatively constant load profile in busses, trains, trucks, aircrafts and ships to a highly transient load profile and often highly demanding environmental conditions in passenger cars, last mile delivery vehicles and special vehicles [32] [33] [34] [35] [36] [37].

The different applications require different modes of operation, designs of the stacks and systems, and consequently different material degradation rates and associated average voltage drops are expected. The degradation of PEM fuel cell stacks, including the membrane-electrode-assembly (MEA), the gas diffusion layers, the bipolar plates and the sealing gaskets is a core topic of PEM

fuel cell research that has lost none of its relevance in terms of materials research through to application over the last decades. However, with knowledge of the underlying mechanisms and causes of PEM fuel cell degradation, it is possible to optimise the materials, the cell and the stack design and the operation mode within the given conditions in order to achieve the longest possible life time [38].

Automotive applications demand a service life of 5000 to 8000 hours with a 10% loss of performance, which is referred to as degradation. For fixed stationary systems, a lifetime of up to 40,000 hours is required. To achieve this goal, understanding potential degradation due to mode of operation (start/stops, transient, etc.) is critical [39].

Based on a report of DOE (Department of Energy) the fuel cell system lifetime targets for class 8 long-haul tractor-trailers are between 25,000 and 30,000 hours. However, the report does not consider an efficiency loss based on the lifetime [40].

Beside performance and lifetime, degradation directly impacts the efficiency (consumption) of fuel cell systems. It is recommended that in the medium and long term, efforts are being made to cover degradation effects also from a regulatory perspective. This could be done taking up approaches as currently developed for batteries at UNECE level ("Heavy Duty Battery Durability"). As a follow-up step, this data could then be considered by Regulation (EU) 2017/2400 and VECTO in order to enable a robust comparison of the energy consumption of the different propulsion technologies.

3.2.3 Work package 2.2.3: Elaborate a vehicle simulation approach for FCEV in VECTO

Based on the FCS component test described in the previous section and the already existing model for xEV powertrains, the following elements are additionally required for the simulation of FCHV in VECTO:

- Limitation of operating range of FCS at vehicle level
- Generic model for energy consumption for FCS conditioning
- Operating modes and result matrix for FCHV in VECTO
- FCHV generic operation strategy in VECTO

These elements are described in the following sections.

3.2.3.1 Limitation of operating range of FCS at vehicle level

For several components, VECTO and Regulation (EU) 2017/2400 offer the possibility of limiting the certified operating range during component testing by means of a declaration at vehicle level. Examples are transmissions or electric motors, for which a maximum torque or a maximum speed can be specified following the provisions in Annex III. The same feature is also proposed for FCS, specifically the input of the following values:

Table 11: Limitation of FCS operation at vehicle level

Parameter	Unit	Effect
FCS minimum electric output power	W	Operation range of FCS in VECTO simulation is limited to max ($P_{\min, \text{FCS_Certification}}$, $P_{\min, \text{Vehicle_Declaration}}$)
FCS maximum electric output power	W	Operation range of FCS in VECTO simulation is limited to min ($P_{\max, \text{FCS_Certification}}$, $P_{\max, \text{Vehicle_Declaration}}$)

These values are taken into account by the generic FCHV strategy in VECTO. In addition, an input parameter for limiting the maximum gradient of the power change of the FCS (default setting: 3 seconds from P_{\min} to P_{\max}) was included in the VECTO test version. However, this parameter is not proposed as an official input (in accordance with Annex III), as it is likely to be difficult to verify in practice. Due to the chosen approach of the generic FCHV strategy the strategy, which results in very stable FCS operating points (see section 3.2.3.4), this parameter should not have any impact on the simulation result for real FCHV configurations.

3.2.3.2 Energy consumption of the FCHV powertrain auxiliary consumers

For FCHV, the energy demand of the auxiliary consumers associated with the operation of the powertrain can be grouped into the following two elements:

- Power demand for conditioning of the e-motor and battery
- Power demand for conditioning of the FCS

As far as a) is concerned, approach and numerical values as already defined for the electric motors and battery for PEV and S-HEV can be used (Table 12).

Table 12: Generic power demand conditioning e-motor and battery

Mission profile	Generic electric power demand [W]
Long haul	600
Regional delivery	600
Urban delivery	550
Municipal	550
Construction	600
Heavy Urban	600
Urban	600
Suburban	650
Interurban	800
Coach	850

Furthermore (i.e. in addition to comparable PEVs), the FCS needs to be cooled. The energy demand for this purpose can vary significantly depending on the FCS load, mission profile (i.e. wind speed), ambient conditions and also the arrangement or design of the cooling system in the vehicle, possibly to a greater extent than e.g. for an ICE. Accordingly, meaningful modelling approaches in VECTO were discussed extensively in the TF-FCS meetings. However, as no information on the design of the cooling system is available to VECTO, it was decided to retain the established approach as a function of the cycle for modelling the auxiliaries assigned to the FCS. Table 13 shows draft values based on the discussions in the TF-FCS. ACEA has announced that it will submit an agreed proposal at a later stage. It is recommended to review this in the framework of later activities.

Table 13: Generic power demand conditioning FCS

Mission profile	Generic electric power demand [W]
Long haul	1500
Regional delivery	1500
Urban delivery	1400
Municipal	1400
Construction	1500
Heavy Urban	1500
Urban	1500
Suburban	1600
Interurban	2000
Coach	2100

3.2.3.3 Operating modes for FCHV

Since fuel cell vehicles have two energy storage systems (i.e. a fuel tank and a battery), they are considered to be hybrid vehicles called FCHV. Thus, for such vehicles the well-established procedures for HEV in VECTO apply, where two principal operating modes exist:

- **Charge-depleting (CD) mode** for all xEV that can be externally charged with electric energy (i.e. OVC feature)
 - The vehicle is primarily – or even solely – powered by electric energy from the battery and the SOC may fluctuate but decreases on average while the vehicle is driven.
 - The electric energy from the battery has priority and the FCS is only used in case the electric storage cannot provide the demanded electric propulsion power.
 - Thus, in charge-depleting mode also a certain amount of fuel consumption could occur in addition to the electric energy consumed.
- **Charge-sustaining (CS) mode** for all hybrid vehicles (i.e. vehicles which can draw energy from a consumable fuel and from an electric energy source)

- The vehicle is primarily powered by the FCS and the energy stored in the battery may fluctuate but, on average, is maintained at a neutral charging balance level while the vehicle is driven.
- The applied FCHV control strategy and the accompanying post-processing method result in a neutral SOC over the cycle.
- This results in the propulsion energy over the entire cycle being provided exclusively by the fuel and the electric energy consumption being zero by definition.

Whether a FCHV is simulated in both modes or only in CS mode is determined solely by the availability of an OVC feature in the vehicle. The general boundary conditions applicable for both modes are described in detail in section 4.2.1.2.

According to the requirements of Regulation (EU) 2017/2400, VECTO shall also determine the "Zero CO₂ emission range" (ZCER), for the calculation of which the most complex case is an H₂ powered vehicle that also has an electric driving mode. Details on how the ZCER, consisting of the part allocated to the hydrogen storage system and the part allocated to the electric storage system, is determined by VECTO are explained in section 3.4.

3.2.3.4 FCHV generic operation strategy in VECTO

In order to simulate FCHV in VECTO in the operating modes described in section 3.2.3.3, generic control strategies are required for the FCS since the electric output of FCS is decoupled from the vehicle's propulsion power demand due to the fact that the battery is utilized as electric buffer.

The generic control strategy applied for the **CD mode** is rather straight forward since due to the fundamentals defining this mode the electric energy from the battery has priority over the one from the FCS. Thus, the vehicle's powertrain draws the energy from the battery and just in case battery power is not sufficient to cover the actual propulsion power demand, the FCS will be engaged to supply the additional demand which will be exactly delivered by the FCS without taking system efficiency into account. This additional rule is deemed to be of no practical relevance when looking at the actual vehicle concepts (either range-extender or fuel-cell dominant) and shall merely be seen as a fall-back in case such a very rare situation occurs in the VECTO simulation due to all its generic assumptions. A real vehicle might simply operate at reduced power in this case, but since the specific OEM strategy is not known by VECTO, some generic assumption needs to be made allowing an equal and fair comparison of all different vehicles (i.e. same required propulsion power demand in this specific case). The occasional usage of the FCS in this case could result in a small amount of hydrogen consumption over a mission even in the CD mode.

As opposed to the CD mode, the **CS mode** requires a dedicated approach for controlling the operation points of the FCS. The fact that the power output of FCS is decoupled from the vehicle's propulsion power demand by using the battery as buffer allows the FCS following the fluctuating actual power demand of the vehicle in a damped way with reduced dynamics which in turn leads to an increased system efficiency and durability. Since the fundamental assumption of the CS mode is that the SOC needs to be balanced over a longer time horizon, all energy needs to be provided by the FCS ultimately. This leads to the basic idea of the generic control strategy for the CS mode where the FCS needs to provide the average electric power demand (including all losses occurring due to energy buffering in the battery) over a longer horizon. When looking at the typical shape of an efficiency curve as function of the output power of a FCS (as exemplarily shown in Figure 46), one can easily deduct the generally valid principle that the lower the power demand the better the

efficiency – at least this is valid for most of the possible operation range. Thus, for a given combination of vehicle and cycle, the basic idea of the generic operation strategy is to make the averaging horizon as long as possible in order to smooth out almost all fluctuations in propulsion power demand and reach the lowest possible averaged power level for a specific mission which in turn leads to the most efficient system operation.

This approach is also reasonable when one thinks about the possibilities of route data and smart preview features that are available in today's vehicles as well as additional assessment of the driving history, which rather easily allows calculating some kind of average power level over a longer horizon. Small deviations from that average power level that occur due to unforeseen events (e.g. interaction with other vehicles on the road, de-tours, changes in driving speed etc.) can be easily accounted for by monitoring the development of the actual SOC of the battery versus the estimated one. Once the deviation gets too big, the power level of the FCS can be adapted accordingly. Furthermore, bilateral discussions with industry experts have also revealed that the operation strategies used in real vehicles are all based on this generally applicable logic due to the typical shape of the efficiency curve. Of course in reality there are a few more parameters (e.g. component durability, aging, thermal behaviour, limitations of system dynamics etc.) to take into account, but still the basic approach is based around these coherences.

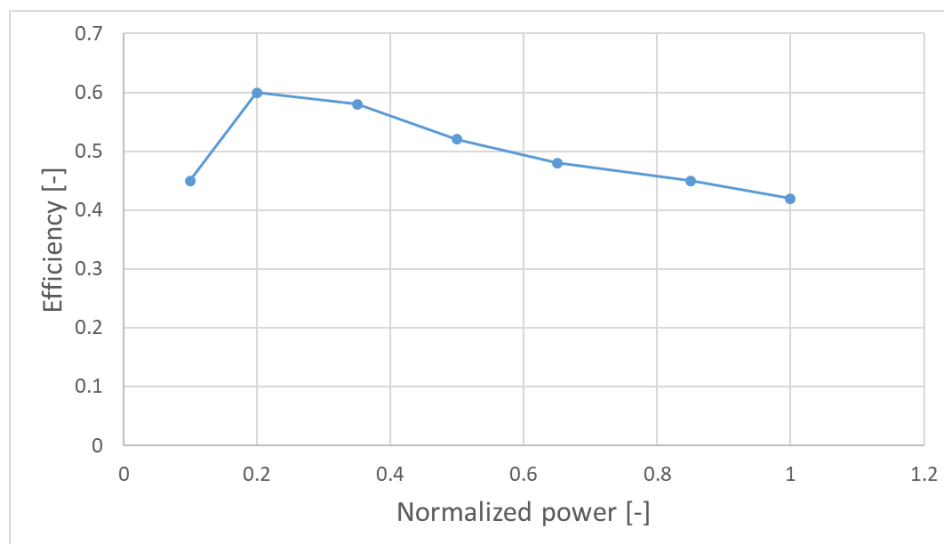

Figure 46: Efficiency curve of a typical FCS (exemplarily)

Since the generic operation strategy needs to work reasonably for any configuration of FCS, buffer battery and vehicle, the averaging horizon needs to be limited by the usable buffer size of the battery and also depends on the electric energy demand of the vehicle in a specific mission. This means, the smaller the battery or the greater the electric energy demand of the vehicle gets, the smaller the averaging horizon will get which in turn leads to a more dynamic operation of the FCS. In order to consider all these additional elements of limitation and make the approach generally applicable, a dedicated workflow for a VECTO FCHV simulation was developed based on two separate simulation runs with a post-processing of the data from the first run in between. The individual steps and all details of this approach are explained in the following paragraphs:

1. **Step 1:** Pre-simulation run as PEV to determine electric power demand for propulsion and auxiliaries
 - a) The vehicle is simulated as PEV using the already established approach with a battery with infinite capacity (i.e. keeping the SOC at a constant level in the middle of the usable SOC range)
 - b) In order to correctly reflect the power limitations of the actual FCHV (i.e. sum of battery and FCS), a special additional battery is installed for that pre-simulation run in the first step only, adding the respective maximum power of the FCS on top of the actual battery installed (but only for propulsion of the vehicle without allowing any additional charging power).
2. **Step 2:** Post-processing of resulting total electric power over time from step 1
 - a) The signal of electric power demand over time is averaged over a certain fixed window size (i.e. the same length for each window) which is defined due to the following limitations:
 - Buffering of energy is limited by battery size so that the applicable SOC limits of the actual battery are not exceeded. In case the SOC limits are violated in a certain window, the window size needs to be reduced accordingly and the averaging calculations need to be repeated until all boundary conditions are fulfilled.
 - The window size is determined by the total distance within a window¹⁰.
 - The averaging windows are placed distance-symmetrically over each actual time step from the pre-simulation (see Figure 49).
 - The maximum window size is given by the complete cycle, thus the cycle is concatenated three times in a row. For time steps near the beginning or end of the cycle, the windows expand over the actual cycle and continue at the adjacent parts at the end or beginning (see Figure 50).
 - b) This means that the largest possible window size without violating SOC limits in any window is applied for the following step 3 in the end.
 - The window size is determined using a binary search, starting with the window size set to the cycle distance (which is the maximum possible window size).
 - For each analysed window size the steps illustrated in Figure 47 are performed.

¹⁰ Thorough analysis campaign performed showed that averaging over time, energy or distance works equally well. The discussions within the TF-FCS and also the fact that a certain preview distance could be assumed as generically valid parameter lead to the conclusion that distance is the preferred parameter to be used for averaging.

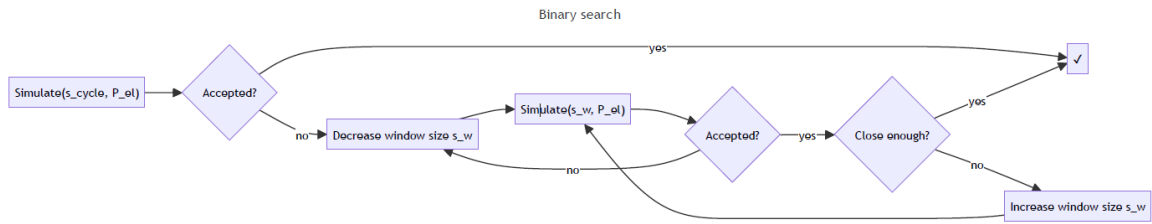

Figure 47: Binary search algorithm for window size

- For each iteration, the window size “s_w” is increased/decreased to the average between the last accepted and the last rejected window.
 - If the deviation of the last rejected window size and the last accepted window size is <5% of the last accepted window size, the search is aborted and the largest accepted window size is used for further calculations (“close enough” criterion in Figure 47).
 - If the window size gets smaller than 5 m, the simulation of the FCHV is aborted since no meaningful operation of the system for a specific mission could be found (i.e. this specific vehicle cannot operate on this cycle).
- c) Some special rules are applied on top, considering the actual power limitations of the FCS:
- In case the resulting average power in a certain timestep is lower than the FCS minimum power, the FCS is switched off and the missing energy for those timesteps will be accounted for in the final post-processing in step 4.
 - In case the resulting average power in a certain timestep is higher than the FCS maximum power (which might occur despite the special battery applied in step 1 due to some inaccuracies), the FCS is operated at maximum power.
- d) For each distance s in the cycle, the average electric power demand over the window defined in accordance with sub-points (a)-(c) above is calculated as $P_{FCS,raw}(s)$.
- e) The signal in sub-point (d) is then corrected for the losses resulting due to all buffering done by the battery.
- f) Violation of SOC limits and determination of initial SOC:
- When determining the largest possible window size, one does not know a priori which amount of energy needs to be buffered at which point in time over the cycle. Thus, defining a fixed initial SOC of the battery would not allow using the full potential of the FCS in all missions in the same way. Therefore, the actual SOC is kept constant at 50% in all the simulations performed in this pre-processing step 2 and VECTO keeps track of a virtual SOC in addition.
 - The resulting maximum virtual SOC range determined over the whole cycle is then compared to the actual SOC range of the battery. If the resulting virtual SOC range required is larger than the actual SOC range of the battery, the current window size is too large and therefore rejected.
 - In case the resulting virtual SOC range required fits the actual SOC range of the battery, the initial SOC is calculated in such a way that it is located exactly in the middle of the minimum and maximum of the virtual SOC trace. Starting

at this initial SOC, the “real” battery losses are determined (as compared to the previous step the battery losses were always determined at 50% SOC leading to slight deviations) by requesting the specific buffering power demand for each distance from the real battery. If now due to the slight changes in battery losses the SOC limits for the current window size are violated, the window size is rejected as shown in Figure 48.

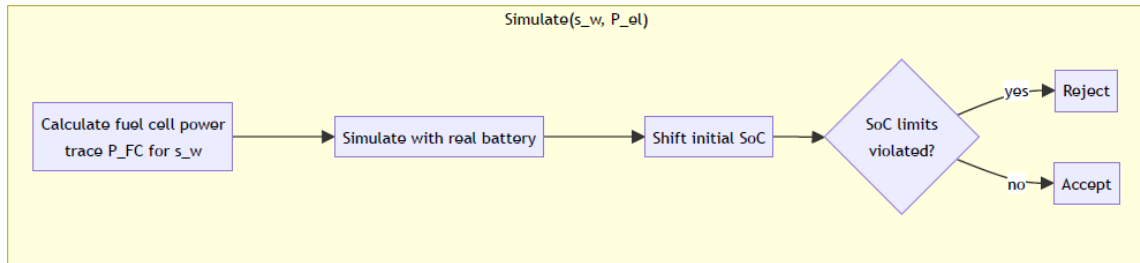

Figure 48: Method for violation of SOC limits and determination of initial SOC

3. **Step 3:** Actual simulation run as FCHV in-the-loop

- a) The FCS is operated following the fixed power trace determined in step 2 (f) covering the average electric power demand and the battery covers the instantaneous deviations from this average electric power demand.

4. **Step 4:** Δ SOC correction in post-processing

- a) Well-established approach as done for all hybrid vehicles in CS mode in VECTO
- b) Δ SOC correction accounts for small deviations from neutral SOC behaviour over cycle due to slight inaccuracies resulting from simplifications made for step 1 and 2 (e.g. variable auxiliary power, battery losses etc.)

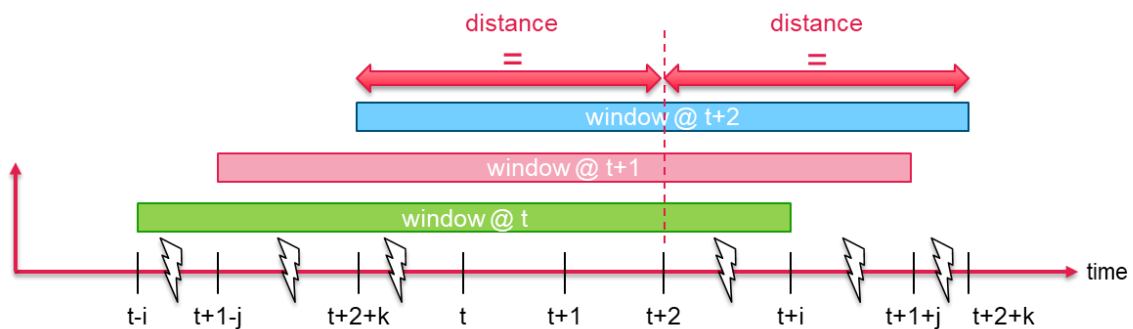

Figure 49: Location of averaging windows for each timestep

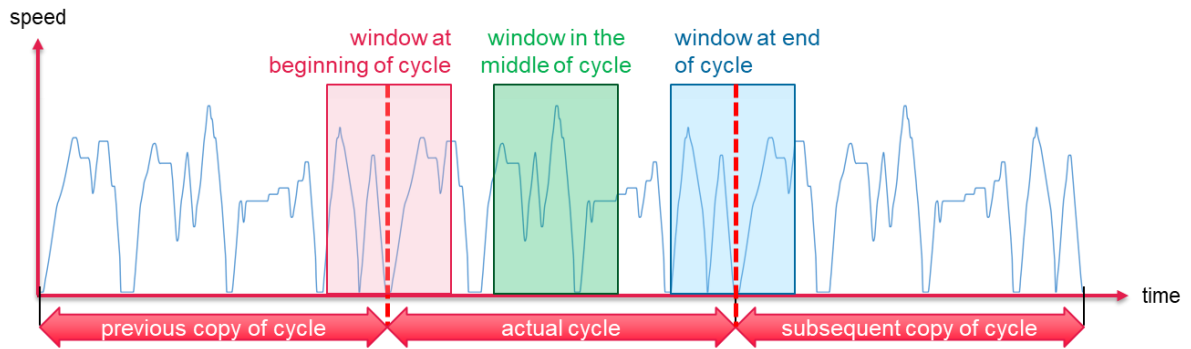

Figure 50: Location of averaging windows at the beginning and end of cycle

Based on these theoretical assumptions, an extensive analysis campaign was performed before the actual implementation into VECTO using an in-house simplified FCHV model in combination with some custom scripts which model the basic behaviour of the generic operation strategy. Some of the basic observations from this preliminary analysis are summarized below:

- For all analysed vehicles (which were based on the real FCHV announced by OEMs for the near future) the averaging horizon is very large, typically over (nearly) the complete cycle. This long horizon was achieved without any violations of SOC limits or power limitations of the battery or FCS.
- Figure 51 shows that the time-resolved power demand given by the dashed blue line gets more and more smoothed the longer the averaging distance gets. For averaging distances of 30 kilometres and more, the resulting load profile of the FCS stays more or less constant at around 100 kW over the complete cycle leading to a very phlegmatized operation with a good system efficiency.
- Figure 52 shows the resulting fuel savings compared to fully dynamic operation of the FCS (i.e. FCS following the instantaneous propulsion power demand) for a typical long-haul truck (VECTO reference loading, 300 kW FCS power, 100 kWh battery) and a typical city bus (VECTO reference loading ,50 kW FCS power, 300 kWh battery). The battery losses for buffering of energy are already accounted for in these results.

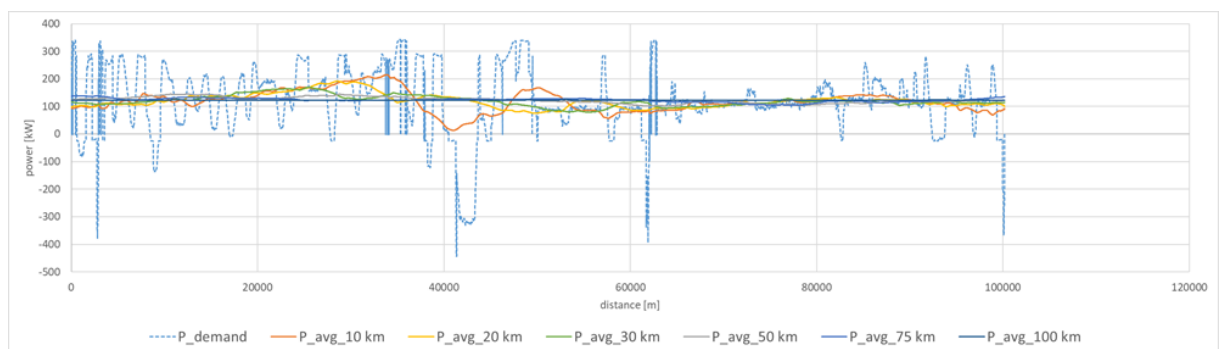

Figure 51: Different averaging horizons (exemplarily for typical long-haul operation)

Long-haul truck in VECTO LH cycle

Mode / Window size	mass H2 [g]	delta to dynamic op.
dynamic operation	10704.3	0.00%
10 km	9280.0	-13.31%
20 km	9269.5	-13.40%
30 km	9235.1	-13.72%
50 km	9183.7	-14.20%
75 km	9188.1	-14.16%
100 km	9159.2	-14.43%

City bus in VECTO HU cycle

Mode / Window size	mass H2 [g]	delta to dynamic op.
dynamic operation	2297.7	0.00%
5 km	2101.8	-8.52%
10 km	2047.6	-10.88%
15 km	2030.3	-11.64%
20 km	2023.6	-11.93%
25 km	2014.0	-12.35%
30 km	2009.2	-12.56%

Figure 52: Fuel savings in comparison to fully dynamic operation of FCS from preliminary analysis

Handling of multiple FCS

Furthermore, the generic FCS operation strategy needs to be able to handle arrangements with more than one FCS installed in the vehicle. This additional feature was requested by industry and is required for both, CD and CS mode. The maximum configuration to be considered – based on feedback from industry – is defined as 2 different FCS components with each single component being able to be used multiple times (up to three) as identical system in a “string”. For this purpose, the generic strategy assembles the individual FCSs into a virtual single FCS, hereafter called “Composite FCS” (CFCS). The structure of a CFCS is shown in Figure 53.

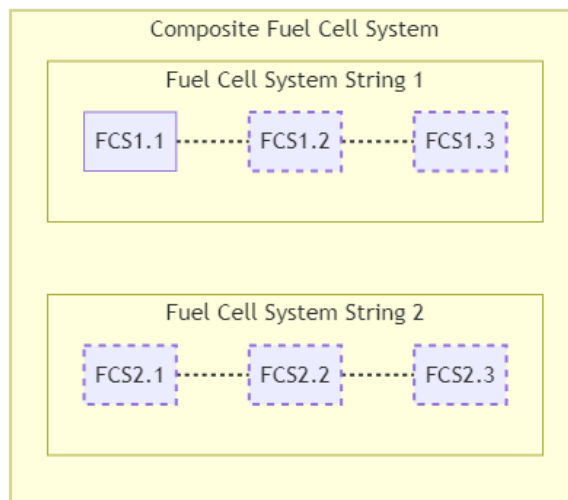

Figure 53: Structure of a Composite FCS in vehicle (dashed elements are optional)

The method for the generic power distribution between different FCS within a CFCS is also based on optimizing system efficiency (as the generically applicable goal to all systems) with the following rules applied:

- The optimum-efficiency power-split over potential two different FCS strings is determined by a pre-calculation before the actual simulation run. The optimum power distribution can be determined using all available data points from the specific FCS inputs. If the strings also consist of several FCSs, these are first combined into a virtual FCS representing the

individual string according to the rules described further down below. Figure 54 **Fehler! Verweisquelle konnte nicht gefunden werden.** shows the applied principle exemplarily for two FCS and three different power demand levels assumed (50 kW, 65 kW and 110 kW), where the power distribution shares for FCS string 1 and FCS string 2 as well as the resulting total efficiency ("Total eta") are marked in yellow.

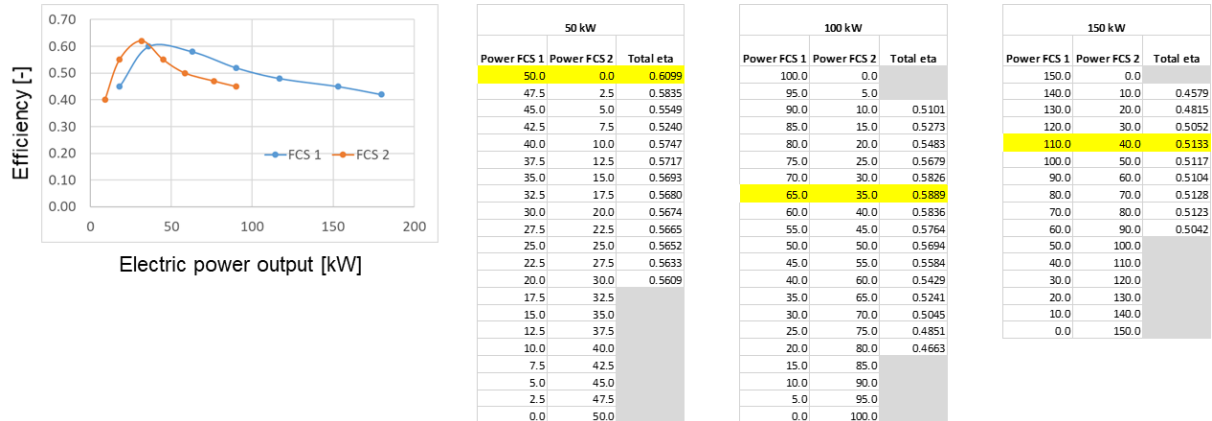

Figure 54: Optimum-efficiency power-split over two different FCS strings for three different power demand levels (exemplarily)

Figure 55 shows in more detail the algorithm for determining the optimal split between the strings for a specific load point. In the example, the share of string 1 results from the lowest H₂ consumption from the light blue curve at approx. 0.12.

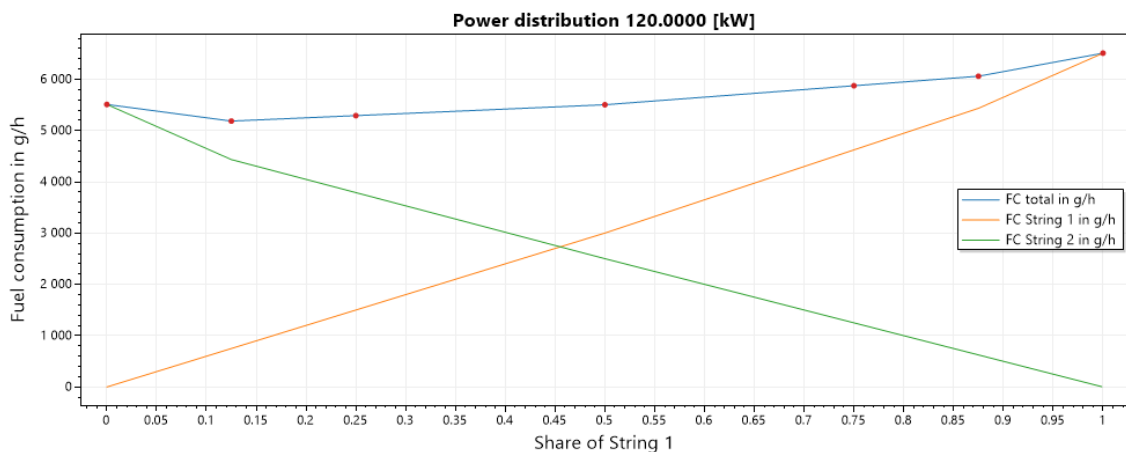

Figure 55: Algorithm for determining the optimal split between the strings for a specific load point

The following rules apply for the distribution of the requested power from a string of several identical FCSs to the individual FCSs:

- H₂ consumption curves for 1, 2 and 3 active FCS are analysed.
- In the case of several active FCSs, the power is distributed evenly among the active systems.

- Using the resulting curves, the optimal number of active FCSs can be determined for each power requested by the string based on the minimum for H₂ consumption.

The principle is illustrated in Figure 56. The resulting characteristic curve (hydrogen consumption over requested power) for the FCS string is the light blue line. The dashed red lines show the resulting fuel consumption for all different scenarios (i.e. one, two or three systems are active within their operation limits) and one can clearly see that the light blue path is following the minimum possible fuel consumption over the whole operation range in all sections where different possible distributions of power over the individual FCS exist.

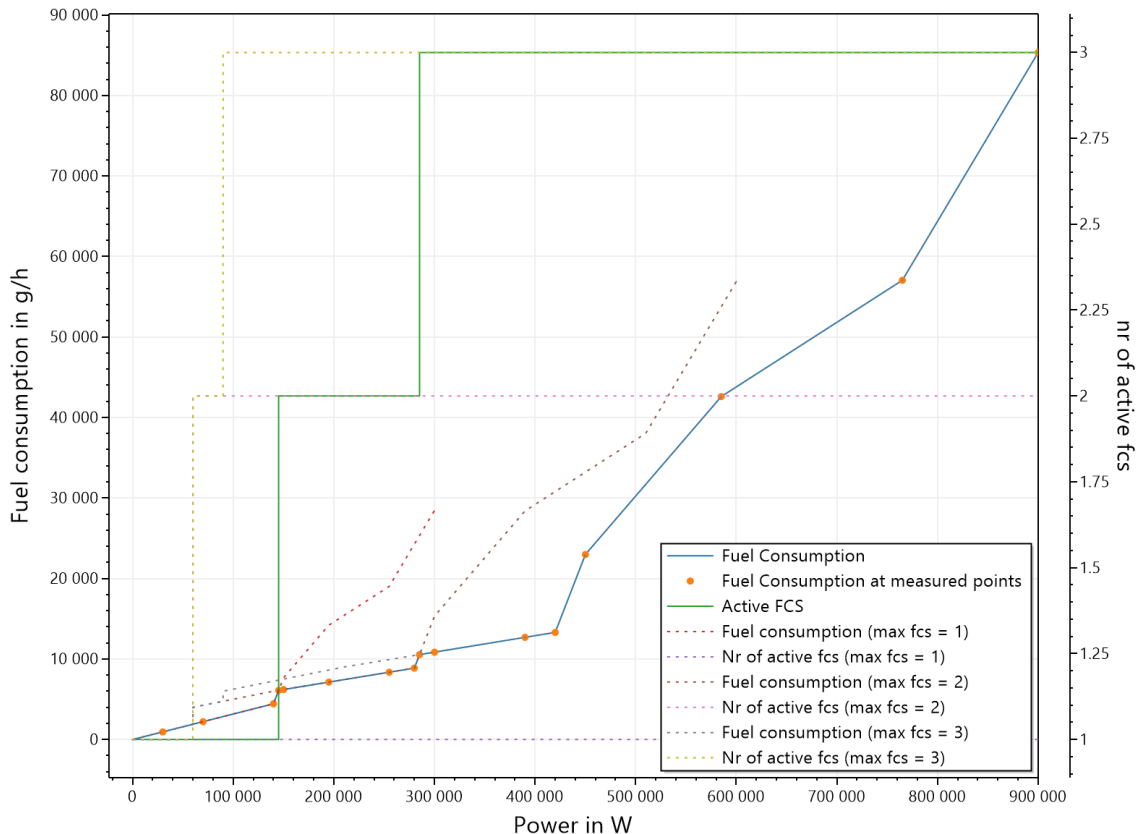

Figure 56: Power distribution within a string of multiple identical FCS (exemplarily)

Finally, there is a special rule for a very unlikely case in real operation, namely that the requested power on a string is lower than the power at the best efficiency point of a single FCS. In this case, a virtual "time splitting" is carried out, i.e. for the time step the FCS is operated at the best efficiency point for a fraction of the time corresponding to the requested power. For the rest of the time step, the FCS is considered switched off. In real operation, the FCS would probably be operated at the best efficiency point or switched off for longer periods in such a case. However, this would be difficult to model in VECTO and the solution described above delivers the same end result.¹¹

¹¹ An analogous algorithm is also used for modelling the air compressor for buses.

3.2.4 Work package 2.2.4: Validation

WP 2.2.4 covered activities to validate the approach to simulate FCHV. As with the development of VECTO for other vehicle technologies, the good functioning of the approach can be carried out at three different levels:

- 1) Validation of the quasi-stationary simulation for the FCS component
- 2) Testing of VECTO version with FCHV features by vehicle manufacturers and suppliers and collection of qualitative feedback
- 3) Measurement of FCHV and direct quantitative comparison with the VECTO simulation results

1) Validation of the quasi-stationary simulation for the FCS component

As described in section 3.2.2, the measurement of the hydrogen consumption of the FCS is carried out in a stationary test procedure. From the resulting characteristic curve (hydrogen consumption as a function of the electrical output), the hydrogen consumption is then interpolated in the VECTO simulation in each time step according to the operating point currently selected by the generic FCHV operating strategy. For this approach, the obvious question is how well the hydrogen consumption can be modelled in transient operating conditions of the FCS. For this purpose, Bosch carried out and analysed a dedicated measurement programme. The results were presented at the TF-FCS meeting on 11 February 2022 and are summarised below (Figure 57).

Bosch on the one hand measured a steady-state H₂ consumption curve according to the draft provisions in the Annex. In a second step, measurements of transient cycles with load points changes of different of different heights and frequencies were carried out. The analysis showed that the H₂ consumption in the transient cycles can be calculated from the steady-state data with a deviation of less than 1%. This means that the accuracy of the approach as foreseen for FCS is more accurate than the methodology used for combustion engines. On the basis of these data, the group decided not to undertake any further activities towards extending the component measurement procedure to include transient cycles.

TF-FCS: Bosch support FCS-tests/data

Static / dynamic testing: explanation of procedure / workflow

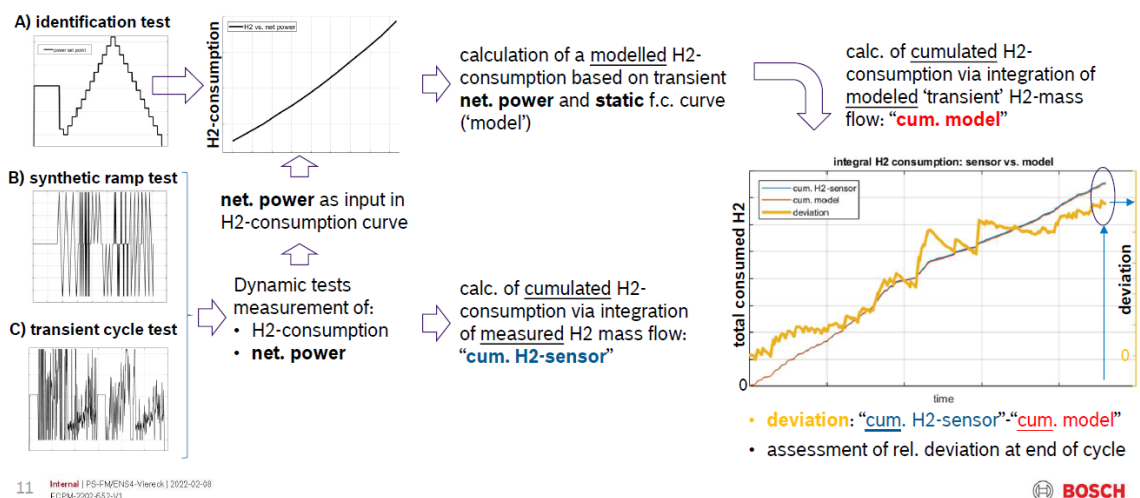

Figure 57: Comparison of fuel consumption interpolated from a stationary test vs. dynamic testing results

2) Testing of VECTO version with FCHV features by vehicle manufacturers and suppliers and collection of qualitative feedback

This activity was the main focus in the development of HEV and PEV features in previous VECTO development steps. The VECTO development version with the FCHV features could only be completed and distributed in the last month of the project, as discussions in the TF-FCS on the component measurement procedure and the FCHV simulation approach continued into spring 2023. TUG will hold a workshop in early autumn '23 to present these functionalities. This will be followed by a feedback phase of 2 months, after which any necessary changes will be discussed in another workshop and incorporated into VECTO by TUG.

3) Measurement of FCHV and direct quantitative comparison with the VECTO simulation results

As with the development of the VECTO HEV and PEV features in previous development steps, no validation could be carried out at this final level in the project, as neither concrete vehicles for measurements nor data from measurements already carried out were available. Analogous to the current "proof of concept" process for HEVs and PEVs, it is therefore proposed that this be done at a later date, e.g. through measurements at the DG JRC. The timeline here is much less critical than for HEVs and PEVs, as the first FCHVs are not expected on the market before 2027.

3.3 Subtask 2.3: Internal Combustion Engines (partly) operated with hydrogen fuel

In order to integrate hydrogen propulsion technologies based on internal combustion engines (ICE) technology into VECTO the following work packages were carried out:

- Work package 2.3.1: Review technologies and consultation of stakeholders
- Work package 2.3.2: Elaboration of a component testing procedure
- Work package 2.3.3: Elaborate a vehicle simulation approach for ICE operated with hydrogen fuel in VECTO
- Work package 2.3.4: Validation

The results and the status quo are described in the following sections.

3.3.1 Work package 2.3.1: Review technologies and consultation of stakeholders

In WP 2.3.1, the currently relevant propulsion technologies based on an ICE fuelled with hydrogen were analysed. The period envisaged in the analysis was set at around 2024 to 2030. In application, this timeframe should approximately match with the application of the third and fourth amendment of Regulation (EU) 2017/2400.

For the investigations, a questionnaire was drafted and distributed to industry (vehicle and engine manufacturers) in summer 2021. The questionnaire contained not only questions on the relevance of various specific technologies, but also on the open points or challenges with regard to the pollutant emissions or VECTO certification of these systems and the question whether the manufacturers were willing to provide test data for validation purposes. The answers to the latter

two points are discussed in the description of WP2.3.2 and WP2.3.3, the template of the questionnaire is included as separate document `Task2_H2_ICE_Questionnaire.docx`.

In total 12 replies to the questionnaire were received, Table 14 gives an overview of the number of respondents and their split between OEMs (vehicle or engine) and supply industry.

Table 14: Responses received from OEMs (vehicle or engine) and supply industry

	number	Pure H2		DF H2/Diesel		DF H2/others	
		definitely planned	uncertain	definitely planned	uncertain	definitely planned	uncertain
OEMs engine/vehicle	7	2	4		3		
Supply industry	5	5		2	1		2

The most relevant outcomes can be summarized as follows:

- No OEM indicated other than pure H₂ technology as relevant
- Availability for testing in pilot phase (around Q3 2022)
 - 4 institutions indicated general availability
 - 2 of them would also have vehicles available
 - No testing outside of industry premises was deemed possible
- Identified issues regarding VECTO method
 - No big issues identified regarding CO₂ component certification, only some technical details to be solved
 - Prerequisite for adapting existing Annex V of Reg.(EU) 2017/2400 (i.e. regarding ICEs) is the coverage of H₂ ICE technologies in UN Reg. 49
 - Implementation of pollutant type approval methods in UN Reg. 49 is time critical since references need to be included in CO₂ regulation

In the further course of the project, several companies came forward with the information that a dual fuel concept with H₂+Diesel is also seen as a technology option for the application period of the third amendment and should therefore be considered relevant.

Therefore, the following technologies were considered in the further work:

- ICE with pure H₂ technology
- ICE with dual fuel technology with H₂+Diesel

3.3.2 Work package 2.3.2: Elaboration of a component testing procedure

The measurement procedure for the certification of H₂ ICEs within the framework of VECTO can be based in most parts on the existing provisions for ICEs operated with carbon-containing fuels as defined in Annex V of Regulation (EU) 2017/2400. The few elements to be regulated separately specifically for hydrogen engines are as follows:

- Mandated accuracy of mass flow measurement for hydrogen

In this regard, the existing measurement methods and reachable accuracy for hydrogen was discussed within the Task Force for Fuel Cell Systems (TF-FCS). The defined requirements can be directly taken over to testing of H₂ ICE.

- References to the type approval regulations for pollutant emissions (EURO VI based on Regulation (EC) No 595/2009 and its amendments)

Currently, there is no option for pollutant type approving a hydrogen fuelled ICE in the EURO VI legislation. Furthermore, the term “dual-fuel” is reserved for concepts which operate on simultaneous combustion of Natural Gas fuels and Diesel fuel. EURO VI refers in the essential points to UN Regulation R49 which is currently being amended (period 2023/24) to include H₂ ICE technologies. The concrete drafting of Annex V of Regulation (EU) 2017/2400 was therefore not possible during the project duration, as the aforementioned legislative processes have not yet been completed.

- Reference fuels

For VECTO, a reference with CO₂ content and lower heating value needs to be defined.

For the time being, based on an extensive analysis of both, Annex V of Regulation (EU) 2017/2400 as well as UN Reg. 49 and also the discussions in the drafting group of the H₂ pollutant TA regulation, a list of all issues to be addressed in Annex V of Regulation (EU) 2017/2400 was compiled (see Table 15). This table can serve as a basis for the implementation into the actual legislative text of Annex V in the context of the activities of eth HDV CO₂ determination board.

Table 15: Items to be considered for implementation of hydrogen fuelled engines into legislative text of Annex V of Regulation (EU) 2017/2400

Item	Reference in Annex V	Comment
Reference fuel – characteristics and requirements	Point 3.2	Either reference to EURO VI legislation or UN Reg. 49 or implement dedicated Appendix to Annex V
Reference fuel – provisions for determination of NCV	Point 3.2	Add special provisions that for hydrogen a fixed NCV value can be assumed (due to high purity of reference fuel)
Reference fuel – special provisions for switching of tanks	Point 3.2	Apply special provisions established already for gaseous fuels
Reference fuel – special provisions for hydrogen dual-fuel engines	Point 3.2.1	Add special rules for selection of fuels and allowed combinations (only hydrogen plus Diesel)
Measurement equipment requirements	Point 3.5	Add requirements for hydrogen mass flow based on final values agreed by Taskforce-Fuel Cell Systems

Item	Reference in Annex V	Comment
Requirements for emission monitoring	Point 4.3.5.7.2	Reference to applicable pollutant limits from EURO VI type approval need to be added for pure hydrogen engines and dual-fuel hydrogen engines
Corrected specific fuel consumption figures over WHSC	Point 5.3.3.1	Standard NCV for hydrogen needs to be added in Table 4
Engine Information Document	Appendix 2	Needs to be updated with all relevant parameters newly added to UN Reg. 49 for hydrogen engines
Engine CO ₂ –Family definitions	Appendix 3	Potential additional requirements implemented into UN Reg. 49 need to be taken over
Method for conformity of CO ₂ emissions and fuel consumption related properties	Appendix 4 – Sub-Point 5.3 (b) E. and Sub-Point 6.1 and Sub-Point 7.6	Adapt methodology based on total CO ₂ emissions to be based on energy for hydrogen dual-fuel engines
Input parameters for the simulation tool	Appendix 7	Adapt engine data with allowed value for new fuel types (i.e. H2 PI and H2 CI)

3.3.3 Work package 2.3.3: Elaborate a vehicle simulation approach for ICE operated with hydrogen fuel in VECTO

Based on the outcome of WP 2.3.1 and also 2.3.2 the existing approach in VECTO was adapted accordingly. For single fuel hydrogen engines the existing methods based on engine fuel flow maps in combination with various correction factors can be used straight forward, but new data for the fuel type hydrogen as well as the corresponding net calorific value of the hydrogen reference fuel were implemented into VECTO in order to be able to calculate the respective energy consumption values. Furthermore, the XML schema was adapted accordingly to allow for hydrogen as valid fuel type input.

Also for the so called “dual-fuel” engines, i.e. engines operating on combustion of two fuels simultaneously, the approach developed in the preceding project for integration of gaseous-Diesel dual-fuel engines into the CO₂ certification framework was used as basis for further work. The corresponding development version of VECTO in principle already allows for ICEs to be simulated in dual-fuel mode for any arbitrary combination of fuels. Also, the scheme for the XML input data was already designed in that way. The existing basic functionality for combinations of Diesel and

gaseous fuels was adapted in all elements to work also for engines with hydrogen as declared fuel type.

Also the VECTO Engine pre-processing tool was adapted with the following new elements:

- New fuel type hydrogen as well as the corresponding net calorific value of the hydrogen reference fuel were added
- GUI was adapted accordingly to allow selection of hydrogen as fuel type
- WHTC correction factor calculation method was adapted to work for hydrogen dual-fuel engines (based on the established methodology for NG dual-fuel engines)
- Output routines were adapted accordingly for hydrogen
- Output of XML files was adapted to respective version of XML schema implemented into main VECTO software

3.3.4 Work package 2.3.4: Validation

For this activity, all potential candidates were contacted based on their feedback given in work package 2.3.1 to provide test data from engine dyno testing of such concepts. A test campaign was designed based on the methods developed in the preceding project for integration of gaseous-Diesel dual-fuel engines into VECTO. Unfortunately, no OEM indicated availability of such engines within the given timeframe where the development progress was at least close to series application in order to deliver useful input to the procedure.¹²

Nevertheless, since the basic methodology for handling of combustion engines is the same also for engine concepts using hydrogen as fuel – even for hydrogen dual-fuel concepts one can look at the work done for NG dual-fuel engines in the past, since they operate with the same principle – a validation is not necessarily seen as a requirement and does not necessarily compromise the validity of the overall procedure.

3.4 Hydrogen range (H2R) and "Zero CO₂ Emission Range" (ZCER)

This section documents the formulas for calculating the hydrogen range (H2R) as well the zero CO₂ emission range (ZCER), which needed to be elaborated in such a way that they cover all types of hydrogen-powered vehicles.

Range is an important feature for hydrogen-powered vehicles, as a storage system capable of holding a large amount of energy is much more difficult to design for hydrogen fuel than for carbon-based fuels. Accordingly, VECTO shall also report the corresponding "hydrogen range" (H2R), i.e. the distance which can be driven by a vehicle based on the usable amount of H₂ fuel, as a result.

¹² In the development process, ICEs are optimised for operation in stationary points in a first step. Only in a second step is the complex application to transient operation carried out. For any validation activity with regard to VECTO, it is crucial that the second step is already fully completed, i.e. that the motor application is ready for series production. This is because the main element to be investigated in a validation would be whether the concept with the WHTC correction factors (mainly reflecting effects from transient operation) works sufficiently accurately.

H2R can be calculated from the usable H₂ storage capacity (value in kg) determined according to section 3.5 and the distance-related hydrogen fuel consumption FC_{H2} (value in kg/km) as simulated by VECTO.

A hydrogen propulsion system can also be applied in combination with an electric propulsion system (architectures FCHV or H₂ ICE HEV). In case such a H₂ - electric hybrid vehicle also has a feature for external charging with electric energy (OVC), the fuel consumption in charge sustaining mode (CS) is the relevant result for calculating the H2R.¹³ This results in the general formula for H2R:

$$H2R = \frac{Cap_{H2,usable}}{FC_{H2,CS}}$$

where:

H2R	Hydrogen range [km]
Cap _{H2,usable}	Usable hydrogen storage capacity [kg]
FC _{H2,CS}	Distance specific hydrogen consumption (for OVC vehicles the result for the CS mode) [kg/km]

Furthermore, the value for ZCER needs to be calculated by VECTO. Here, for a general formulation, in the case of H₂ vehicles that are also equipped with an OVC electric drive, both zero emission energy sources need to be taken into account. Following the operation modes simulated for OVC vehicles – Charge depleting mode (CD) and charge sustaining mode (CS) - ZCER is calculated as follows:

- 1) Range drivable in CD mode ("electric driving") until the battery is depleted, which is already provided by VECTO as "Actual charge depleting range" (R_{CDA}), plus
- 2) Range drivable in CS mode ("hydrogen operation") until the hydrogen is consumed.

For a general formulation it must be taken into account that a certain small amount of hydrogen could also be consumed in CD mode (case FCHV: switching on the fuel cell if the peak power of the battery cannot cover the power requirement in the cycle; case H₂ ICE HEV: boosting with H₂ ICE if the electric drive cannot provide the power requirement in the cycle). This gives the general formula for calculating ZCER for hydrogen-powered vehicles with:

$$ZCER = R_{CDA} + \frac{Cap_{H2,usable} - FC_{H2,CD} \cdot R_{CDA}}{FC_{H2,CS}}$$

where:

ZCER	Zero CO ₂ emission range [km]
R _{CDA}	Actual charge depleting range [km]
Cap _{H2,usable}	Usable hydrogen storage capacity [kg]
FC _{H2,CD}	Distance specific hydrogen consumption as simulated for the CD mode [kg/km]

¹³ A detailed explanation of the VECTO calculation modes for electric vehicles and the different electric ranges is given in section 4.2.1.

$FC_{H_2,CS}$ Distance specific hydrogen consumption as simulated for the CS mode [kg/km]

For vehicles which do not have an OVC feature, the ZCER is identical to H2R as R_{CDA} is zero.

By transformations, it can be shown that the ZCER determined based on the formula above is identical to the value that results simply from the sum of the values for EAER (which is already a standard output for OVC vehicles) and the H2R as defined above:

$$ZCER = EAER + H2R$$

where:

ZCER Zero CO₂ emission range [km]

EAER Equivalent all electric range [km]

$$EAER = R_{CDA} \cdot \frac{FC_{H_2,CS} - FC_{H_2,CD}}{FC_{H_2,CS}}$$

H2R Hydrogen range [km]

R_{CDA} Actual charge depleting range [km]

$Cap_{H_2,usable}$ Usable hydrogen storage capacity [kg]

$FC_{H_2,CD}$ Distance specific hydrogen consumption as simulated for the CD mode [kg/km]

$FC_{H_2,CS}$ Distance specific hydrogen consumption as simulated for the CS mode [kg/km]

For dual-fuel hydrogen vehicles, it is recommended that no further sophisticated corrections be made here - i.e. in the calculation of ZCER – related to considering the small amounts of CO₂ from diesel pilot injection. The technologies currently under discussion will have only very small amounts of CO₂ ("type 1A") and would - in accordance with the Commission's February 2023 proposal for the revision of the HDV CO₂ standards - anyhow be classified as zero emission vehicles.

3.5 Hydrogen storage capacity

During the project period, DG CLIMA decided that VECTO should also calculate the range that can be driven with hydrogen. To accomplish this, VECTO needs to know the amount of hydrogen that can be actually be used in typical vehicle operation. Determining this amount in a standardised way is not completely straight forward due to the complex storage methods used for H₂ to achieve sufficient storage density. No existing standard is known for this purpose. Therefore, a suitable approach needs to be elaborated and implemented for Regulation (EU) 2017/2400 and VECTO.

This specific subject was not part of the tasks specified in the ToR of the project, but was taken forward by the project team (TUG and HyCentA) as part of the discussions in the TF-FCS. The achieved status of the methods should make it easily possible to finalise the last remaining details in the course of the activities of the HDV CO₂ Determination Board for the 3rd Amendment. This status is documented below.

Relevant H₂ storage technologies

From the discussions with stakeholders, the following three hydrogen storage technologies were identified to be covered by Regulation (EU) 2017/2400:¹⁴

- Compressed Gaseous Hydrogen (CGH₂)
- Subcooled Liquid Hydrogen (sLH₂)
- Cryo-compressed Hydrogen (CcH₂)

The most important storage technology for the application period of the 3rd Amendment is clearly CGH₂, the only technology that is currently ready for the market. Whether vehicles of the other two technologies will actually appear in the fleet in this time frame is currently uncertain.

For all technologies, the basic approach in determining the usable tank capacity is that it is calculated from the difference in hydrogen content between the full tank and the state of the tank in which no more hydrogen can be withdrawn. The latter depends on many influencing factors, including the demand of the hydrogen propulsion system with regard to minimum supply pressure and the operating conditions as to how exactly the tank was "emptied". In order to find a meaningful balance between effort and accuracy, an indicative accuracy of the resulting value of approx. 5% (i.e. e.g. 50 km with a range of 1000 km) was targeted.

Compressed Gaseous Hydrogen (CGH₂)

For CGH₂, it is proposed to calculate the usable H₂ tank capacity in VECTO based on two tank specifications as defined in UN Regulation No. 134, which are

- "Volume of the compressed hydrogen storage system" (VCHSS)
- "Nominal working pressure" (NWP)

as well as three characteristic system pressures to be declared for VECTO (Table 16).

¹⁴ A comprehensive description of different H₂ storage technologies for vehicle applications and the required tank infrastructure can be found in [58].

Table 16: System pressures to be declared for CGH2

Parameter name	Parameter definition	Comment
Minimum working pressure of the CGH ₂ tank system ($p_{min,tank}$)	means the minimum pressure to which the tank can be emptied in typical operation	to be declared at vehicle level (Annex III)
Minimum supply pressure demand of the hydrogen propulsion system ($p_{min,supply,veh}$)	means the minimum pressure that must be provided by the hydrogen supply for the operation of the hydrogen propulsion energy converter	to be declared at vehicle level (Annex III)
Minimum hydrogen supply pressure ($p_{min,supply,comp}$)	means the minimum pressure that must be provided by the hydrogen supply for the operation of the component (FCS, ICE).	to be declared at component level and certified together with the component input XML (Annexes V and Xb)

VECTO can then calculate the usable H₂ mass (m_{usable}) using the following formula:

$$m_{usable} = V_{CHSS} \cdot \left(\rho_{15^{\circ}C, NWP} - \rho_{15^{\circ}C, \max(p_{min,tank}, p_{min,supply,veh}, p_{min,supply,comp})} \right)$$

The pressure-dependent density values at 15°C ($\rho_{15^{\circ}C}$) can be interpolated by from the hydrogen specifications as laid down in UN Regulation No. 134 revision 02 (Table 17).

Table 17: Hydrogen specifications UN Regulation No. 134 revision 02

Temperature (°C)	Pressure (MPa)												
	1	10	20	30	35	40	50	60	65	70	75	80	87.5
15	0.8	7.9	14.9	21.2	24.0	26.7	31.7	36.1	38.2	40.2	42.1	43.9	46.5

Subcooled Liquid Hydrogen (sLH₂) and Cryo-compressed Hydrogen (CCH₂)

For sLH₂ and CCH₂, due to the presence of extreme low temperature conditions, the determination of a standardised usable tank capacity is more difficult than for CGH₂, since the thermodynamic states of the H₂ in the tank during the refuelling process and the operation of the vehicle are significantly more complex.

Firstly, the external boundary conditions to which the usable H₂ quantity used in VECTO refers to need to be defined for both systems. These boundary conditions are:

- I. The vehicle operation pattern defining the state of the residual hydrogen in the tank before the refill
- II. The state of the hydrogen as provided by the hydrogen filling station.

The vehicle operation pattern defining the state of the empty tank before the refill should be defined sufficiently precise to ensure the earlier mentioned target of max. 5% tolerance for resulting H₂ storage capacity, but not unnecessarily specifically so as not to unnecessarily complicate potential vehicle tests. The current state of discussions is to defined that the vehicle has been in operation for a certain period of time (e.g. 4 hours) before refuelling from the empty state.¹⁵ This boundary condition can probably be defined uniformly for both storage technologies sLH₂ and CcH₂.

The state of the hydrogen as provided by the hydrogen filling station refers to the pressure and temperature which is actually available at the refill. These can probably vary within certain limits in the real operation of a filling station according to standards currently being developed.¹⁶ The corresponding conditions must be defined separately for sLH₂ and CcH₂, as different refuelling systems are used.

Secondly, it has to be defined how the resulting value for usable H₂ mass can be obtained. In contrast to the approach proposed for CGH₂ (input of volume and pressures plus subsequent calculation of usable mass in the VECTO tool itself), it is recommended for sLH₂ and CcH₂ to define the usable mass directly as an input parameter, which should be determined by the manufacturer based on the above mentioned boundary conditions using own calculations. The main reason for this recommendation is that upstream physical quantities, such as pressures and temperatures, would be less easy to verify for sLH₂ and CcH₂ than the useful mass itself. Furthermore, the development of a calculation model for each of the two storage technologies for the remaining period until the 3rd Amendment seems unrealistic.

As mentioned in the introduction to this section, the H₂ storage technologies sLH₂ and CcH₂ are not expected on the market in the near future. A review of the proposed provisions is recommended as soon as experience with the operation of such vehicles in the fleet is available.

3.6 Result matrix for hydrogen fuelled vehicles in VECTO

Due to the different operation modes (i.e. CD and CS mode – see section 3.2.3.3 for details) and the two sources of CO₂ emission free energy (i.e. battery and hydrogen tank) for a FCHV with OVC feature, the generated results regarding energy consumption and various ranges get rather complex. Thus, this chapter summarizes the general result structure of VECTO for a specific FCHV.

The general structure of all result elements shown in Figure 58 and Figure 59 is given by the structure defined in the applied XML schema for VECTO. Each result block for a certain mission profile (i.e. cycle) marked in different shades of blue in both figures, consists of two different sub-sets of results for each specific payload (i.e. low and representative) marked in different shades of yellow. Each of those sub-sets for a specific vehicle and payload combination consists of three individual elements for CS mode, CD mode and a “Total” element. The “Total” element contains either the individual results from the CS mode in case of a non-OVC vehicle or the weighted results from CD and CS mode in case of an OVC vehicle in order to depict the average operation of the vehicle in real driving conditions (see section 4.2.1.2 for details). Whether a weighted result for

¹⁵ The operation pattern defined here should reflect range-oriented driving, because only such vehicles can be expected with sLH₂ and CcH₂.

¹⁶ Influencing factors here are, for example, how often H₂ was dispensed.

OVC-FCHV should be provided by VECTO was still under discussion as this report was compiled. For propulsion systems that do not produce CO₂ emissions, this is neither necessary nor meaningful, since the actual shares of electric and fuel energy depend highly on the price (and maybe also availability for hydrogen) of the two energy sources. Thus, the remark given by footnote 2 in Figure 59 suggests that these weighted results are not provided for OVC vehicles operated with hydrogen. Furthermore, the last line in both tables called “weighted” provides an overall result by considering each single “Total” result for a specific vehicle and payload combination by a defined weighting factor depending on the vehicle sub-group representing the average operation pattern.

Figure 60 defines what the different colour codes in the result matrix represent. The fields in grey with three minus signs indicate that this specific result is not available for a certain vehicle or mode and will thus not be present in the VECTO XML output.

Figure 58 shows the applicable result elements for a FCHV without OVC feature (non-OVC FCHV) with the following characteristics:

- The “final results” for a specific mission profile and payload combination are always given in the XML element “Total”. In this case, “Total” is identical to “OVC mode CS”.
- The “Fuel consumption” element also includes hydrogen (i.e. different units are available for different fuels, hydrogen is always mass based).
- The element “Hydrogen range” is determined by the specific fuel consumption and the usable tank capacity (for details see section 3.4).
- For a non-OVC FCHV the “Zero CO₂ emissions range” is identical to the “Hydrogen range”.

Mission profile	Payload	Result level	v_average	Fuel consumption per fuel type	CO ₂ emissions	Electric energy consumption	Actual charge depleting range R _{CD} A	Equivalent all electric range (EAER)	Hydrogen range (H2R)	Zero CO ₂ emissions range
			[km/h]	[lit/100km] ...	[g/km] ...	[kWh/km] ...	[km]	[km]	[km]	[km]
#1	low	OVC mode CD	---	---	---	---	---	---	---	---
#1	low	OVC mode CS	(X)	(X)	(X)	---	---	---	(X) ¹	(X) ¹
#1	low	Total	X	X	X	---	---	---	X ¹	X ¹
#1	rep.	OVC mode CD	---	---	---	---	---	---	---	---
#1	rep.	OVC mode CS	(X)	(X)	(X)	---	---	---	(X) ¹	(X) ¹
#1	rep.	Total	X	X	X	---	---	---	X ¹	X ¹
#2	low	OVC mode CD	---	---	---	---	---	---	---	---
#2	low	OVC mode CS	(X)	(X)	(X)	---	---	---	(X) ¹	(X) ¹
#2	low	Total	X	X	X	---	---	---	X ¹	X ¹
#2	rep.	OVC mode CD	---	---	---	---	---	---	---	---
#2	rep.	OVC mode CS	(X)	(X)	(X)	---	---	---	(X) ¹	(X) ¹
#2	rep.	Total	X	X	X	---	---	---	X ¹	X ¹
#3	---	---	---	---	---	---	---	---
weighted			---	X	X	---	---	---	X ¹	X ¹

Figure 58: Result matrix for a FCHV without OVC feature (non-OVC FCHV)

¹ Only for H₂ propulsion vehicles (ICE and FCHV)

Figure 59 shows the applicable result elements for a FCHV with OVC feature (OVC FCHV) with the following characteristics:

- The “Actual charge depleting range” and the “Equivalent all electric range” are typically equal for a FCHV. Only in case battery power is not sufficient for the actual propulsion demand, the FCS might be operated rarely to deliver the remaining power demand resulting in a small amount of additional hydrogen consumption even in the CD mode (for details see section 3.2.3.3).

- Per definition consumption of electric energy can only occur in CD mode (for details see section 3.2.3.3).
- For OVC FCHV the “Zero CO2 emissions range” is defined by the sum of the “Equivalent all electric range” and the “Hydrogen range” (for details see section 3.4).

Mission profile	Payload	Result level	v_average	Fuel consumption per fuel type	CO2 emissions	Electric energy consumption	Actual charge depleting range R _{CDA}	Equivalent all electric range (EAER)	Hydrogen range (H2R)	Zero CO2 emissions range
			[km/h]	[lit/100km] ...	[g/km] ...	[kWh/km] ...	[km]	[km]	[km]	[km]
#1	low	OVC mode CD	x	x	x	x	(X)	(X)	---	---
#1	low	OVC mode CS	x	x	x	---	---	---	(X) ¹	---
#1	low	Total	X²	X²	X²	X²	X	X	X¹	X
#1	rep.	OVC mode CD	x	x	x	x	(X)	(X)	---	---
#1	rep.	OVC mode CS	x	x	x	---	---	---	(X) ¹	---
#1	rep.	Total	X²	X²	X²	X²	X	X	X¹	X
#2	low	OVC mode CD	x	x	x	x	(X)	(X)	---	---
#2	low	OVC mode CS	x	x	x	---	---	---	(X) ¹	---
#2	low	Total	X²	X²	X²	X²	X	X	X¹	X
#2	rep.	OVC mode CD	x	x	x	x	(X)	(X)	---	---
#2	rep.	OVC mode CS	x	x	x	---	---	---	(X) ¹	---
#2	rep.	Total	X²	X²	X²	X²	X	X	X¹	X
#3
weighted			---	X²	X²	X²	X	X	X¹	X

Figure 59: Result matrix for a FCHV with OVC feature (OVC FCHV)

¹ Only for H2 propulsion vehicles (ICE and FCHV)

² Not for H2 propulsion vehicles (ICE and FCHV)

x	individual result simulated in specific mode (i.e. CS or CD)
(X)	result from specific mode (i.e. CS or CD) without direct output but relevant for total results
X	post-processing result from above (i.e. grey X) given as output in total results element
X	weighted result produced by weighted averaging from CS and CD

Figure 60: Key for colour codes in result matrix

3.7 Implementation into VECTO

The methods described in the previous sections for modelling hydrogen vehicles, i.e. FCHVs and vehicles with H2 ICE (pure H2 and dual fuel), were implemented in a development version of VECTO and made available to the Commission and stakeholders for testing.

4 Task 3: Pantograph, catenary and connector systems for electrified vehicles

This task covers the relevant VECTO topics around in-use electric charging technologies as currently already established or under development for HDV applications. Task 3 is divided into three subtasks:

- Subtask 3.1: Review of in-use charging technologies
- Subtask 3.2: Definitions and generic parameters relevant for VECTO
- Subtask 3.3: Implementation into VECTO

Task 3 was elaborated by IDIADA as a key knowledge holder on in-use charging infrastructure in close cooperation with the TUG VECTO development team. In this task, IDIADA assisted in the following categories: 1) information provider, 2) in-field developer expert for heavy-duty charging applications and 3) Support partner for the VECTO system developer for implementing a functional prototype.

In subtask 3.1, a technological review and assessment of the current and future charging systems applicable for various heavy-duty applications has been elaborated. Research and industrial stakeholders, literature and internet have been the sources of information for this task. In addition, the review of in-use charging technologies also considers a regulatory perspective in order to identify which technologies are aligned with the current regulatory framework. The main results of this research were also presented at the stakeholder meetings in June, September and December 2021. The results of Subtask 3.1 are documented in Section 4.1.

Subtask 3.2 comprised the development of methods and parameters to model the influence of in-use charging technologies in VECTO. On this topic, the report provides a full description of the methods developed (i.e. including the basic methods as already implemented in VECTO for the 2nd amendment) for all types of vehicles with off-vehicle charging features and makes concrete proposals on how to model these vehicles in the 3rd amendment of Regulation (EU) 2017/2400.

Subtask 3.3 covered the implementation of the methods in a development version of VECTO.

4.1 Subtask 3.1: Review of in-use charging technologies

4.1.1 Technological review of in-use charging technologies

In this section, the types of charging and connector technologies are described with their attributes followed by discussion on the suitability of these charging methods for heavy duty vehicles. The charging methods for heavy duty vehicles can be classified into two main types namely “Stationary” and “Dynamic” (In-Motion) i.e., the vehicle can charge when stationary or when it is moving. In the stationary type, the sub-classifications are Plug-in, ACD (Automatic connection device) and wireless transfer. Under Dynamic charging, the sub-classifications are Overhead pantograph, wireless transfer, and conductive power transfer from road (Ground-line). In *Figure 61* we can see further sub-classifications.

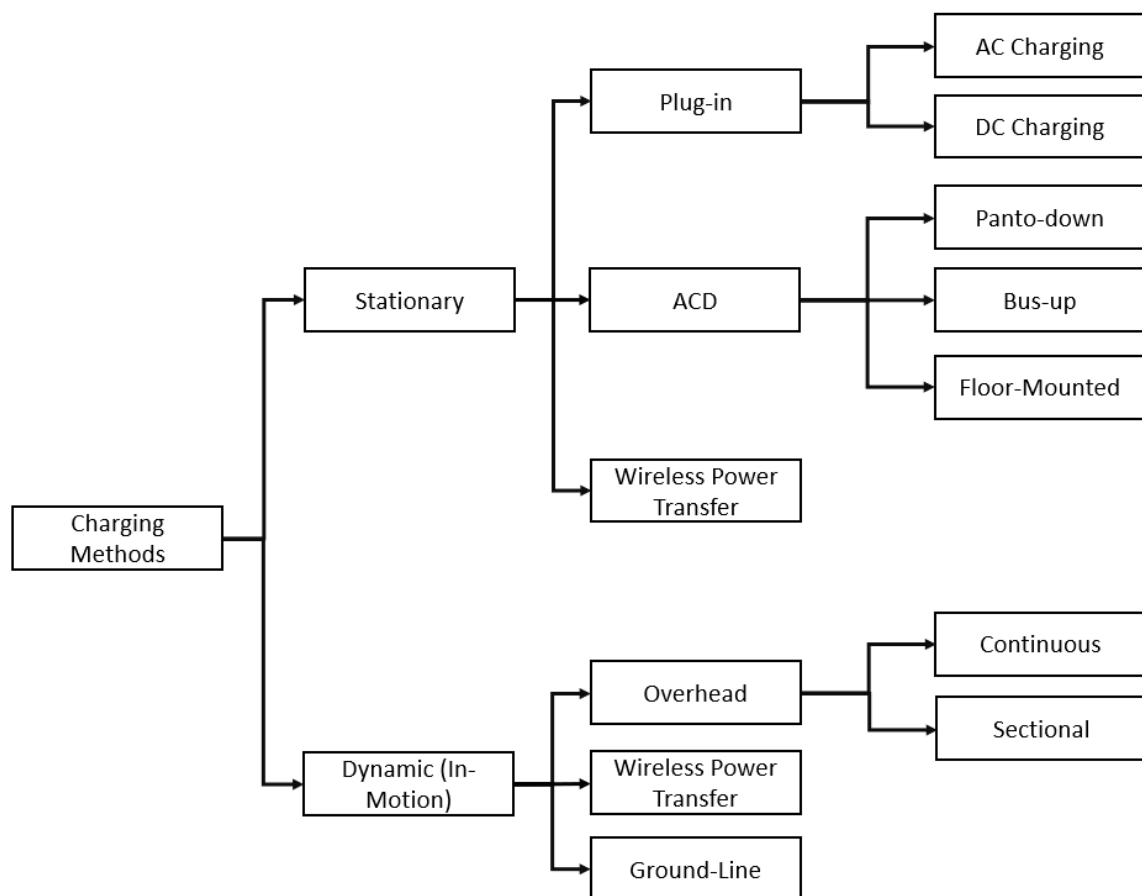

Figure 61: Types of Electrical vehicle charging methods

4.1.1.1 Charging requirements of heavy duty EVs

The information presented here is based on [41]. The report analyses data of long-haul trucks in the USA and estimates the infrastructure needed towards transitioning to zero-emission trucks.

For long-haul and delivery trucks, the report concludes that one 50kW charge point for each truck is necessary. If the delivery trucks work in shifts, then two charge points for three trucks would be enough. Trucks are expected to have a battery capacity of 500 to 1000 kWh. The charging power limits of current fast chargers' is generally around 150 kW. Hence, on average a long-haul truck would need around 5 hours for complete charging. For heavy duty electric vehicles, the charging power provided by AC charging methods are insufficient to charge the vehicle in acceptable time.

4.1.1.2 Manually connected plug-based charging

Different types of charger plugs can be seen in *Table 18* This includes AC, DC and combined charging plugs.

Table 18 Overview of plug-in chargers

	In-use	In-use	In-use	In-use	Proposed	In-use	In-use	In-use	Proposed
Name	Type 1 AC	Type-2 AC	CHAdeMO 2.0	GB/T	ChaoJi	CCS 1	CCS 2	Tesla	High Power Commercial Vehicle Charging Task Force (HPCVC)
Plug design									
Max Power	Up to 7kW	Up to 22kW	1000 V x 400 A = 400kW	950 V x 250 A = 237,5 kW	500 to 900kW	1000 V x 500 A = 500kW	1000 V x 500 A = 500kW	410 V x 610 A = 250kW	1500 V x 2000 A = 3 MW
Communication Protocol	None	None	CAN (CHAdeMO)	CAN (GB/T-27930-2015)	CAN	PLC (ISO 15118)	PLC (ISO 15118)	CAN (SAE J2411)	CAN or Ethernet (ISO 15118)
Location Used	USA	Europe	Global	China	China, Japan	USA	EU, South Korea, Australia	Global	USA, Europe?

	In-use	In-use	In-use	In-use	Proposed	In-use	In-use	In-use	Proposed
Related Standards	SAE J1772-2017	IEC 61851	CHAdeMO (0.9, 1.0, 1.1, 1.2, 2.0)	IEC 61851	CHAdeMO 3.0	IEC 61851 / SAE J1772	IEC 61851	none	none
Notes			Liquid Cooled under development	none	Liquid Cooled variant possible	Liquid Cooled	Liquid Cooled	Liquid Cooled	Liquid Cooled

4.1.1.3 Automated connection devices (ACDs)

The Automatic Connecting Device, ACD, is the automated extendable/retractable mechanism to connect/disconnect EV supply equipment (EVSE) conductive components to vehicle interface.

Automatic connection devices can be classified into three types which are:

- infrastructure mounted (panto-down, Type A)
- roof mounted (bus-up, Type B), and
- floor-mounted (Type C).

In all the three types, the vehicle must be stationary. These technologies are shown in *Figure 62*.

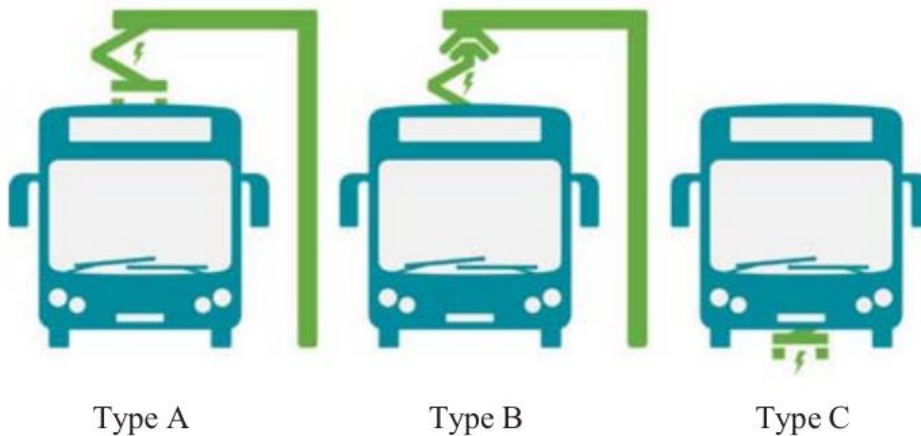

Figure 62 Various methods of automated connection devices [42]

4.1.1.4 Catenary

A catenary curve is the natural curve that a cable, chain, or any other line of uniform weight assumes when suspended between two points. In Catenary charging system, the vehicles are provided energy conductively from overhead cables suspended by poles. Trolleybuses run by obtaining energy from cables overhead, i.e., catenary.



Figure 63: Overhead Catenary System [43]

Catenary systems are also classified as “Continuous” and “Sectional”. In continuous catenary the overhead power lines are installed continuously whereas in sectional catenary it is available intermittently. The type of system influences the configuration of on-board battery system of the electric truck as well as the charging power. Each system has its advantages and disadvantages. A detailed analysis can be found in [44].

4.1.1.5 Wireless Power Transfer

Wireless charging involves transferring energy to the vehicle without any conductive connection. There are different types such as Inductive, Magnetic, Capacitive etc. Inductive transfer is the widely used among these.

This system involves two main sections – transmitter and receiver. The charging power can vary from a few kW to a few hundreds of kW. The charging can occur when the vehicle is stationary or when the vehicle is in motion.

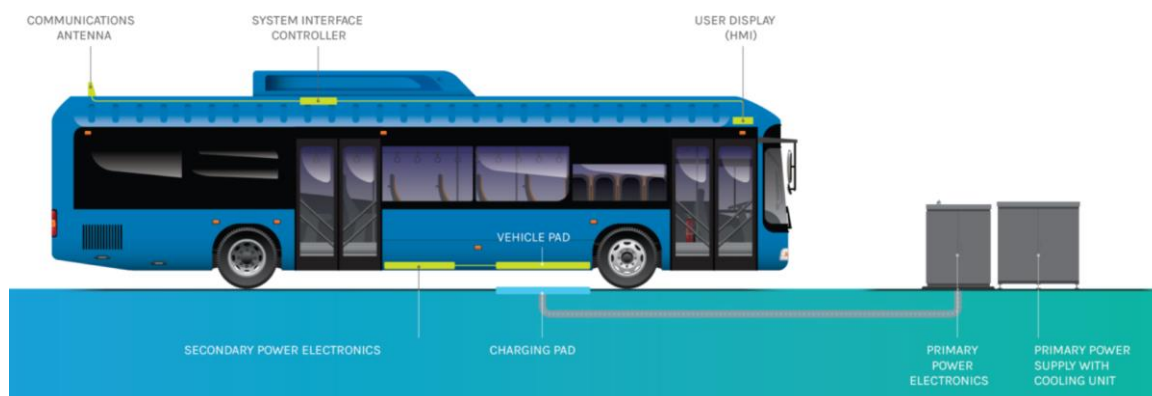

Figure 64: Wireless Power transfer schematic from WAVE IPT [45]

4.1.2 Charging infrastructure deployment in EU

Firstly, we provide a quick overview of the electric vehicles and chargers at a global level and covering also passenger cars and light commercial vehicles. In Figure 65 we see the distribution of electric vehicles and the compatible charging technology. We can see that vehicles with GB/T inlet type occupy 40% of the global EV share.

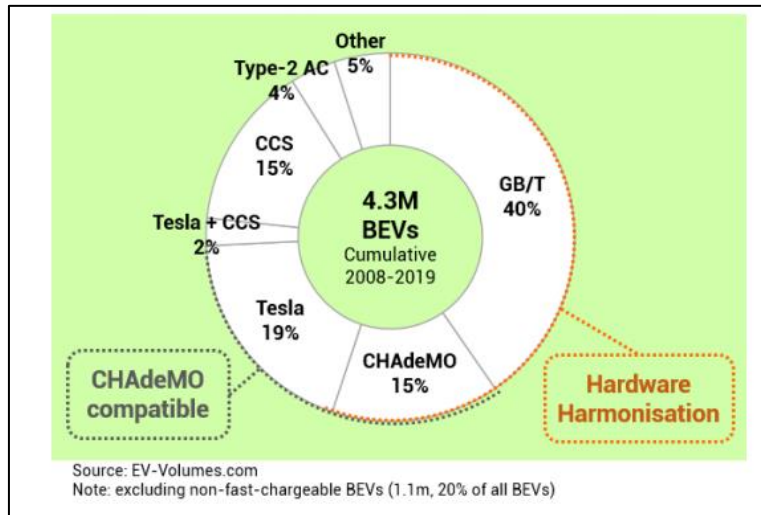

Figure 65: Global BEV share by fast charging inlet type {1}

In Figure 66, we can see distribution of charging inlets around the globe. It can be observed that non-fast charging inlets are the most populous.

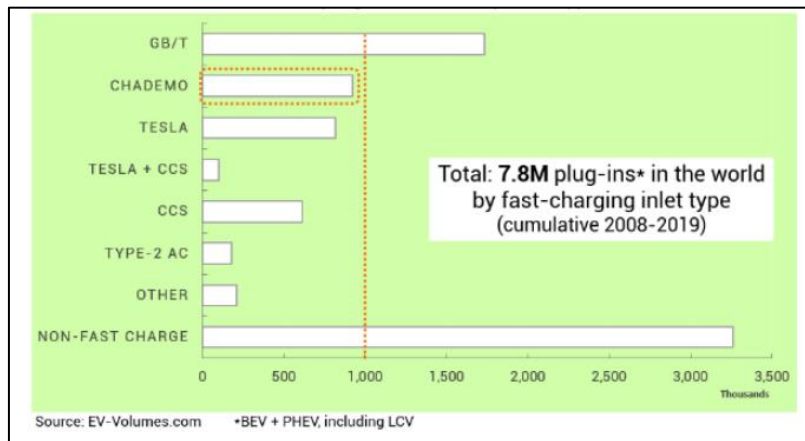

Figure 66 Global plug-in vehicles by inlet type {1}

A charge is considered “Fast charge” by European Alternative Fuels Observatory, when charging power is higher than 22 kW.

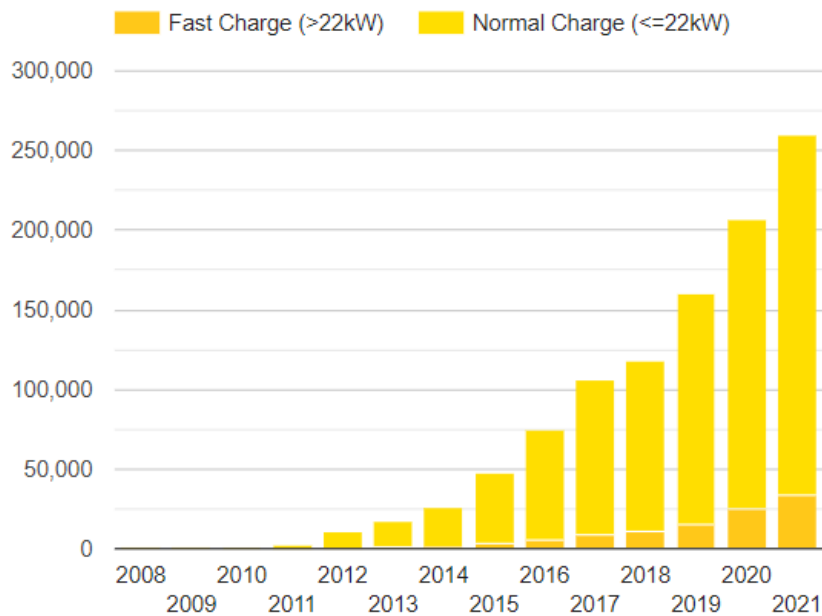

Figure 67. Public recharging points in EU (2021) [46]

In Figure 67, the normal and fast public chargers installed in different European countries are displayed. The top 5 countries with maximum number of public charging stations are Netherlands, France, Germany, Sweden, and Italy as seen in Figure 68. Germany, France, Netherlands, and Italy are the countries with more than 20.000 units per country.

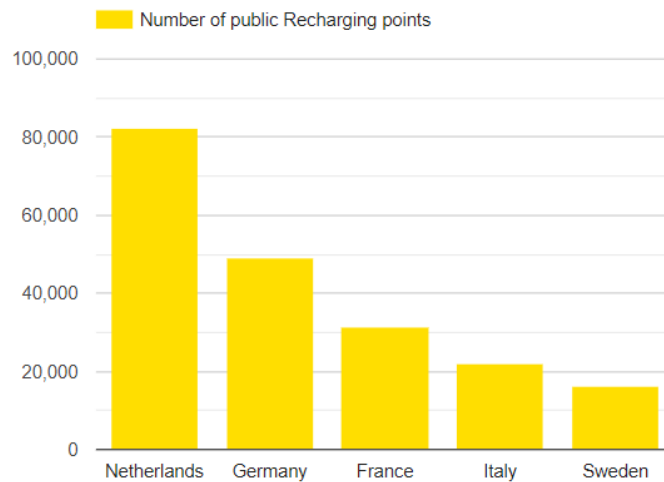

Figure 68. Top 5 Countries number of public recharging points (2021) [46]

However, to get a better understanding of the infrastructure deployment, we can look at the number of high-power chargers installed per 100 km of highway.

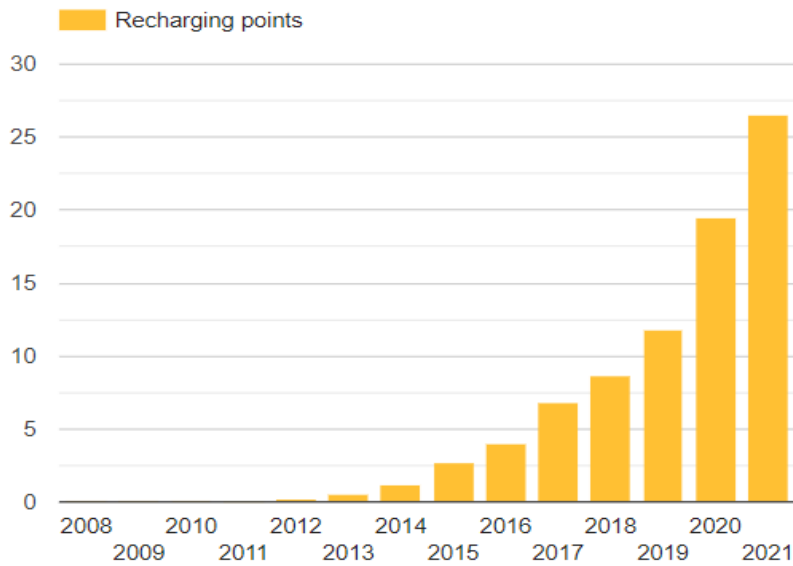

Figure 69. High-Power Public recharger per 100km highway (2021) [46]

As can be seen in Figure 69 the number of high power public chargers per 100 km is having an increasing trend, with the latest number landing the number of high power chargers per 100km at 26.

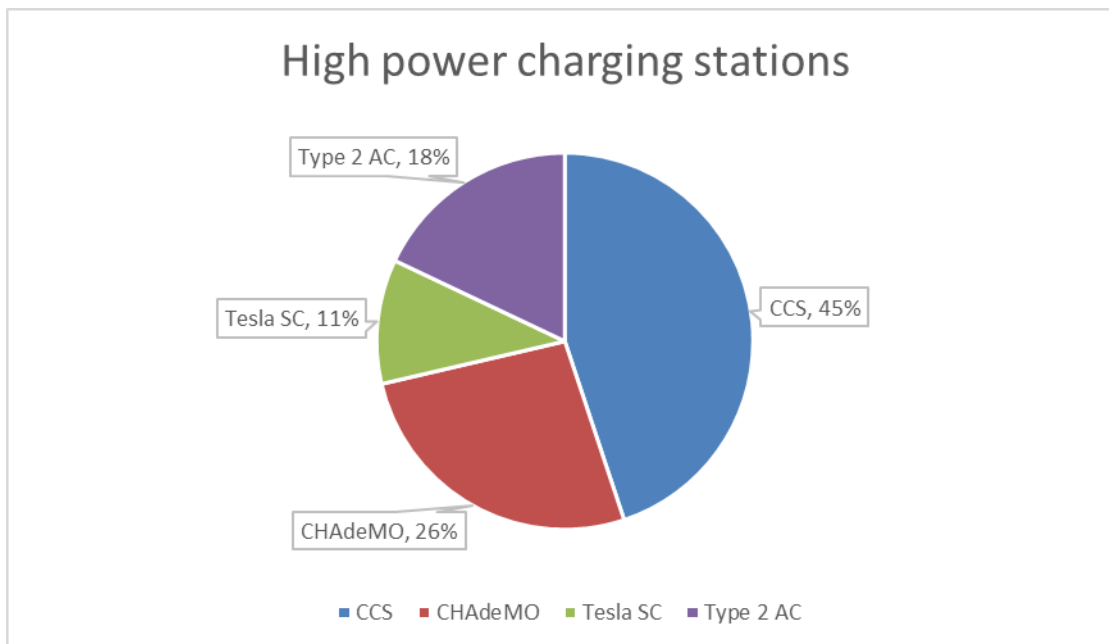

Figure 70. High-Power Public recharging points (2021) [46]

In Figure 70, we can observe the types of public fast chargers in different European countries. Data is available for the following type of chargers: CCS, CHAdeMO and Tesla SC (SuperCharger). The most installed charger type is CCS.

According to the European Alternative Fuel Observatory (EAFO), the number of EV Urban Bus fleet in Europe reaches more than 8.000 vehicles in 2021, as seen in *Figure 71*.

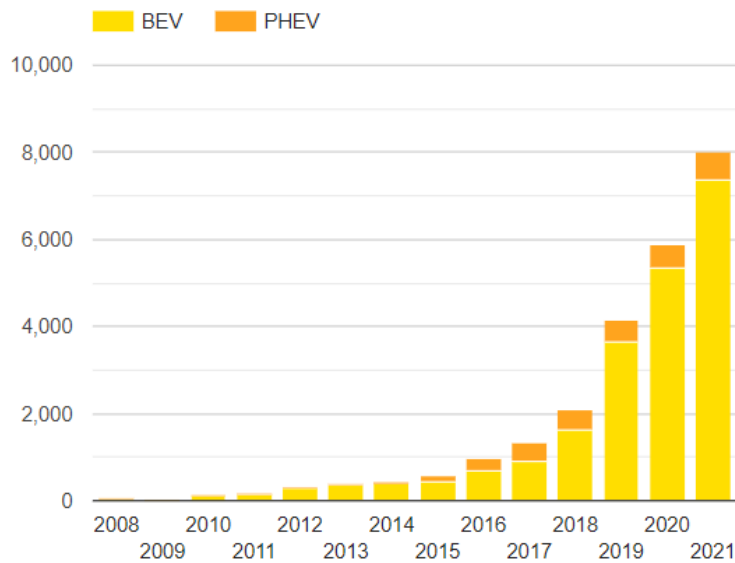

Figure 71. Total EV Urban Bus Fleet in Europe (2021) [46]

The top 5 countries with maximum number of EV bus fleet are Germany, Netherlands, France, Sweden, and Italy as seen in *Figure 72*. Germany and Netherlands are the countries with more than 1.000 units per country.

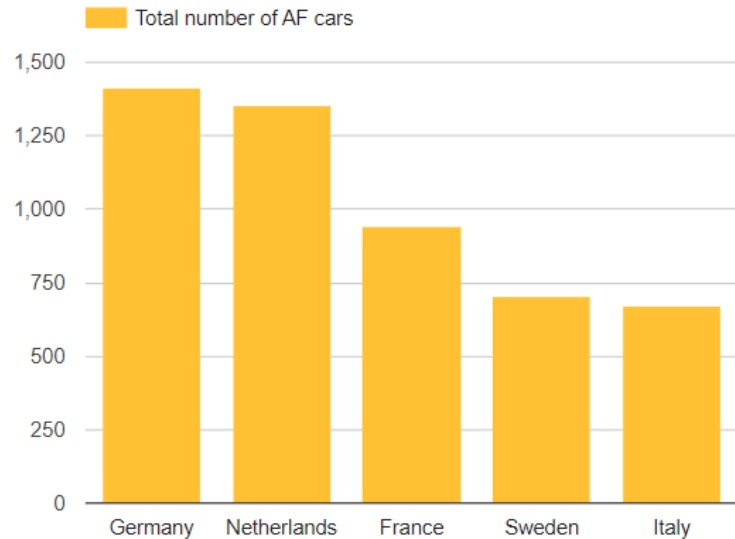

Figure 72. Top 5 country EV Urban Bus fleet electricity (2021) [46]

The number of Heavy-Duty vehicles fleet is lower than EV Urban Bus fleets in Europe as observed in *Figure 73*. A number of around 1.250 has been reached in 2021 and will be increasing during the upcoming years.

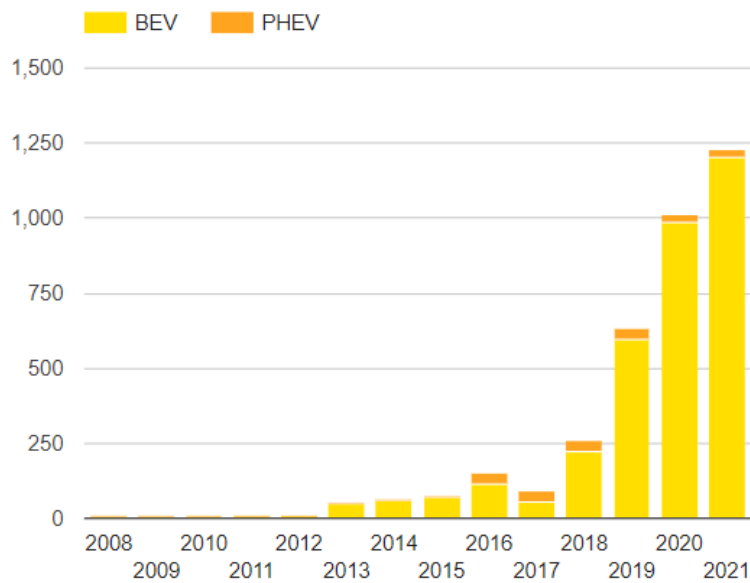

Figure 73. Total Heavy-Duty Fleet in Europe (2021) (European Alternative Fuel Observatory, s.f.)

The top 5 countries with maximum number of EV bus fleet are Germany, Netherlands, Austria, Italy and Denmark as seen in Figure 74. Germany is the only country that has reached more than 600 units according EAFO.

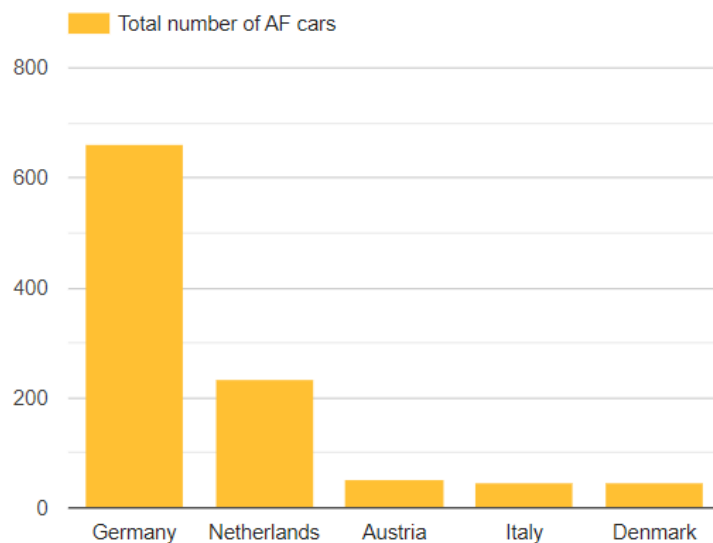

Figure 74. Top 5 country Heavy Duty fleet electricity (2021) [46]

4.1.3 Current Charging regulatory framework

In Figure 75, we can see the various standards and regulations for plug based charging technology at global and national levels.

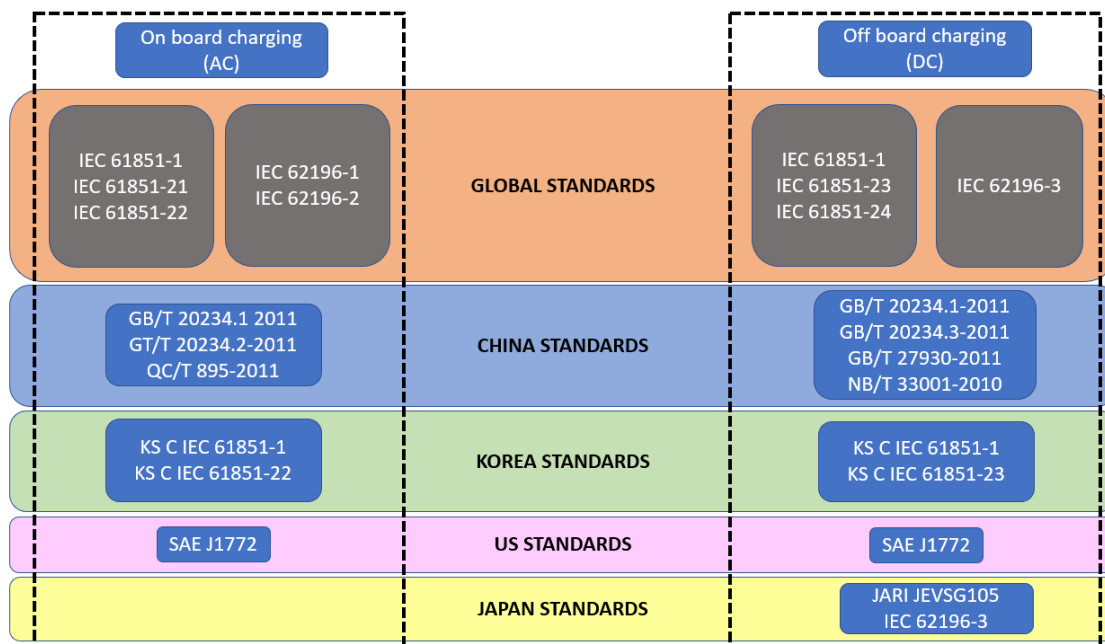

Figure 75 Charging framework for plug-based charging [47]

The regulatory standards followed in Europe is formulated by the International Electrotechnical Commission (IEC). The technical committee on Electrical power/energy transfer systems for electrically propelled road vehicles and industrial trucks (TC 69) publishes the standards related to the conductive, wireless charging as well as battery swap technology.

The standards published by TC 69 are applicable to EVs including trucks, trailers, and special industrial trucks. It is to be noted that trains, trams, and trolleybuses are out of scope of this committee [48]. The technical committee on Electrical equipment and systems for railways (TC 9) covers the standards for metropolitan transport networks including metros, tramways, trolleybuses and fully automated transport systems [49].

4.1.3.1 Conductive charging standards

IEC 61851-1: Deals with EV supply equipment (EVSE) for charging electric road vehicles, with a rated supply voltage up to 1000 V AC / 1500 V DC and a rated output voltage up to 1000 V AC / 1500 V DC. It provides information about the operating specifications and safety requirements of the EVSE.

IEC 61851-21-1: This regulation deals with the electromagnetic compatibility (EMC) of on-board charger for conductive charging of an electric vehicle.

IEC 61851-21-2: This regulation deals with the EMC requirements for off-board electric vehicle charging systems.

IEC 61851-23: This regulation provides general requirements for communication between DC charging systems with input voltage up to 1000 V AC. / 1 500 V DC and an EV.

IEC 61851-24: This regulation provides the requirements of digital communication between a DC charging station and an EV.

IEC 61851-25: This regulation deals with DC charging station requirements with a rated supply voltage of up to 480 V AC / 600 V DC, with rated output voltage not exceeding 120 V DC and output currents not exceeding

100 A DC. It provides the requirements for the DC EVSE where the secondary circuit is protected from the primary circuit by electrical separation.

IEC 62196 regulations deal with plugs, socket-outlets, vehicle connectors and vehicle inlets used in conductive charging of electric vehicles. IEC 62196-1 provides general requirements, 62196-2 details dimensional compatibility and interchangeability requirements for AC pin and contact tube accessories and 62196-3 provides dimensional compatibility and interchangeability requirements for D.C. and A.C./D.C. pin and contact-tube vehicle couplers.

4.1.3.2 Wireless charging standards

Standards for wireless charging have also been created by SAE and IEC. Details are provided in *Table 19*.

Table 19 Wireless Charging Standards

Standard	Title
IEC 61980-1	Electric vehicle wireless power transfer (WPT) systems - Part 1: General requirements
IEC TS 61980-2	Electric vehicle wireless power transfer (WPT) systems - Part 2: Specific requirements for communication between electric road vehicle (EV) and infrastructure
IEC TS 61980-3	Electric vehicle wireless power transfer (WPT) systems - Part 3: Specific requirements for the magnetic field wireless power transfer systems
SAE J2954	Wireless Power Transfer for Light-Duty Plug-in/Electric Vehicles and Alignment Methodology

4.1.3.3 Battery swap technology standards

Battery swapping consists of exchanging a depleted battery with a completely charged battery. There have been implementations made in China and South Korea. This technology has major hurdles such as standardized battery sizes and architecture across companies in order to be viable for wider use in the public.

IEC TS 62840-1: This regulation deals with the general requirements of battery swap technology. It provides an overview of battery swap systems that operate when vehicle powertrain is turned off and the system is working with a rated supply voltage of 1000 VAC /1500 VDC.

IEC 62840-2: This regulation provides safety requirements of battery swap systems.

4.1.3.4 ACDs

IEC 63076: This regulation applies to electrical systems aboard vehicles of the trolley bus type, fed with a nominal line voltage between 600 V DC and 750 V DC. It defines the requirements and constructional advice, especially to avoid electrical danger to the public and to staff. Where special requirements exist for trolley buses, advice is given for mechanical and functional safety, as well as for protection against fire.

IEC 62724: This regulation specifies the requirements of insulating synthetic rope assemblies and is applicable to electric traction overhead contact lines for railways, light railways, tramways, trolleybuses, and other systems. This standard establishes requirements and characteristics of the rope, test methods and checking procedures to be used with the insulating synthetic ropes, together with the ordering and delivery requirements.

IEC 62486: This regulation specifies requirements for the interaction between pantographs and overhead contact lines, to achieve interoperability [50]. It includes the following information:

- the upper line properties for both AC and DC power systems as well as the current collector characteristics
- the requirements for pantograph with individually spring parts of the pantograph head

The following table includes the mechanical, electrical and communication standards used for the different ACD solutions described in this chapter:

Table 20: Standards used for the Types A, B and C Automated Connection Device based solutions

		Type A	Type B	Type C
Mechanical implementation and parking tolerance		EN 50696:2021 -Annex A (normative) - Annex B (normative)		EN 50696:2021 -Annex C (normative)
Electrical implementation		IEC 61851-23-1 CD3 Annex CC case D	IEC 61851-23-1 CD3 Annex CC case E	IEC 61851-23-1 CD3 & Annex KK
Communication	Control Pilot	IEC61851-23-1 CD3 Annex CC case D	IEC 61851-1 Ed. 3 & SAE J1772™	IEC 61851-23-1 CD3 & Annex KK
	Physical layer	ISO 15118-8	ISO 15118-3	ISO 15118-8
	Application layer	ISO 15118-2_OpportunityCharging Rev. 1.3.0	ISO 15118-2	ISO15118-20 (former ISO 15118-2 Ed 2.0 DIS)

SAE J3105 establishes a standard automatic conductive charging system architecture, allowing any vehicle to use any charger that complies with one of the additional particular ACD implementations, regardless of manufacturer. [51]

Table 21: SAE Standards for ACDs

Standard	Title
SAE J3105	Electric Vehicle Power Transfer System Using Conductive Automated Connection Devices
SAE J3105/1	Infrastructure-Mounted Pantograph (CrossRail)
SAE J3105/2	Vehicle-Mounted Pantograph
SAE J3105/3	Enclosed Pin and Socket

SAE J3105-3 describes the enclosed Pin and Socket Connection. It covers the main safety and interoperability relevant requirements for an electric vehicle power transfer system using a conductive automated-charging device based on an enclosed pin and socket design. (See Figure 76).

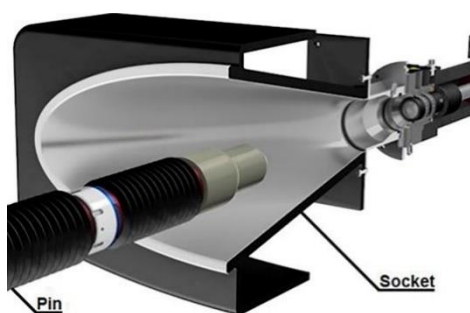

Figure 76. Enclosed Pin and Socket Connection [52]



Figure 77 Automatic fast charging solution by Staubli

4.1.3.5 Communication regulations

ISO 15118: This standard covers the digital communication between an EV and an AC / DC charging station. As part of the Combined Charging System (CCS), ISO 15118 covers all charging-related use cases across the globe. This includes wired (AC and DC) and wireless charging applications and the pantographs that are used to charge larger vehicles like buses [53].

DIN SPEC 70121: This is a German technical specification which is based on an early version of ISO 15118 and is limited to the communication between an EV and a DC charging station. Currently, this specification is being adhered to by the equipment manufacturers and going ahead will be replaced by ISO 15118 version 2.

ISO 15118-2_OppportunityCharging Rev. 1.3.0 (Oppcharge): OppCharge is an industry standard developed by Volvo Bus corporation and several other stake holders which includes Daimler, Iveco, MAN and Scania. OppCharge provides a fast-charging solution for commercial electric vehicles based on a pantograph framework. The system consists of a connector rail that can be mounted on the vehicle's roof, a pole mounted pantograph that connects with the vehicle & transfers electricity, a positioning system that identifies & syncs the position of connector rail and pantograph, and the communication protocol that enables a two-way WiFi communication sequence between the vehicle & charging station. The OppCharge charging stations are available in the output power rating of 150kW, 300kW, and 450 kW.

4.1.3.6 Future standards

In August 2018, CHAdeMO Association and China Electricity Council (CEC) signed an understanding for technical collaboration in co-development of next generation ultra-fast charging standard and to make the CHAdeMO and GB/T chargers interoperable [54].

In June 2020, CHAdeMO and CEC together released a whitepaper with technical details of a new charger technology which can deliver around 900kW.



Figure 78 ChaoJi Connector interface [55]

High Power Commercial vehicle charging: The Charging Interface Initiative e.V. (CharIN e.V) is a registered association with OEMs and Suppliers as members with the purpose of developing and promoting the Combined Charging System protocols. From 2018, the association has been working on a new DC charging standard named **High Power Commercial Vehicle Charging** (HPCVC) standard that will be able to deliver up to 3 Mega Watts of power. It proposes a charging system working at 1500 Volts and 3000 Amperes. This would be able to charge a truck battery pack of 500kWh to 80% in 20 minutes.

- CCS 3.0 is not yet precisely defined. [46]
- Tesla V3 superchargers are now in production.

4.1.3.7 Charging interface promoting associations

Organization	Website
CharIN E.V.	https://www.charinev.org/index.php?id=170
CHAdeMO Association	https://www.chademo.com/
OppCharge	https://www.oppcharge.org/
Open Charge Alliance	https://www.openchargealliance.org/
China Electricity Council	https://english.cec.org.cn/

4.1.4 Charging strategies for HDVs with examples

The high-power charging strategies that apply to heavy-duty vehicles can be mainly classified into two different blocks: Depot/Overnight and Opportunity charging strategies. Further classification can be seen in Figure 79.

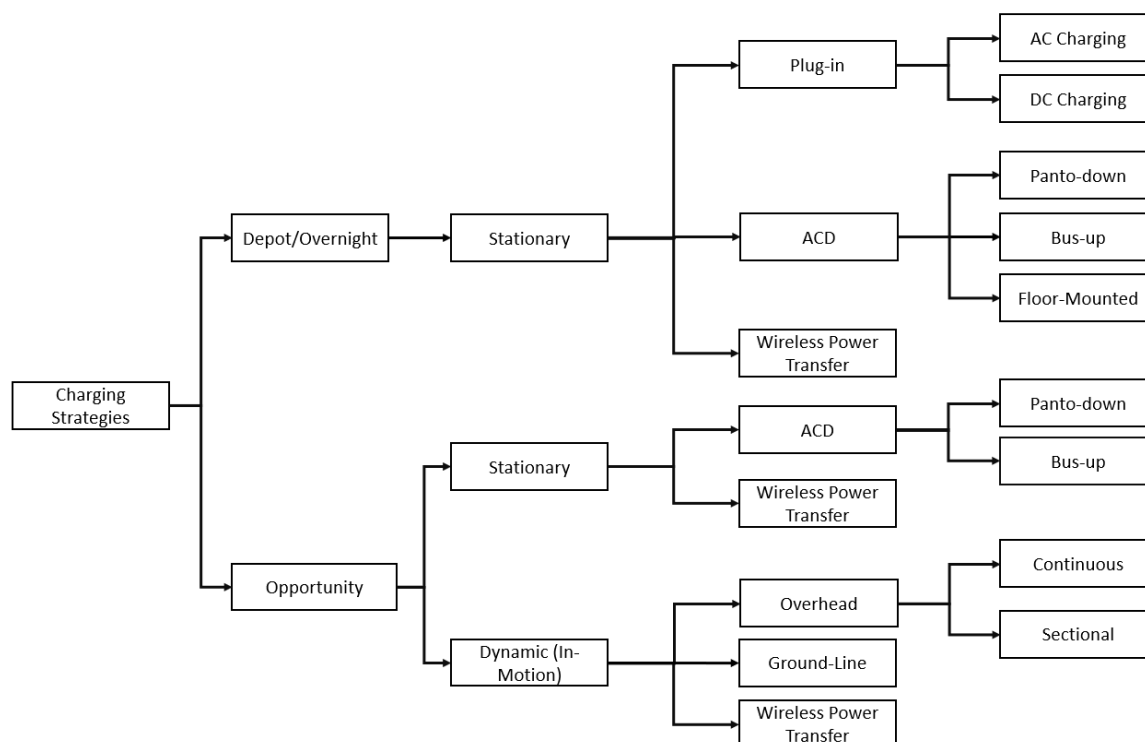

Figure 79: Charging strategies for HDVs

4.1.4.1 Stationary and dynamic charging strategies

Stationary charging occurs when the vehicle is at rest. Dynamic charging, also referred to as In-Motion Charging, is defined as the charging of electric vehicles when in motion. Catenary charging (sectional or continuous), Ground rail systems and wireless dynamic power transfer methods are referred under this strategy. Trolleybuses use dynamic charging methods.

4.1.4.2 Depot / Overnight charging concepts

Pantograph down or inverted pantograph is classified as Type A solution (Figure 80). Type A DC fast-charging solutions range from 150 kW to 450 kW charging power. While Plug-in DC fast chargers are better suited for depots/terminals due to the decreased mechanical complexity and lower price point, we also see a trend to lower power (150kW) pantographs in depots. Charging is fully automatic and secured by a two-way Wi-Fi communication sequence and positioning capabilities. Electric and electric hybrid vehicles are charged at the end stops in order to eliminate impact on the route schedule. With a span of power ratings, charging can be optimized in terms of charging time and battery condition.



Figure 80: Pantograph down ABB solution

Pantograph up or roof-mounted pantograph is classified as Type B solution. Type B DC fast-charging solutions range from 150 kW to 600 kW charging power. This power capacity allows to charge large fleets of electric buses overnight in a range of 50-150 kW per vehicle and during the day with 150 kW up to 600 kW for opportunity charging. As an example, the depot charging installation in Schiphol, Amsterdam is a Type B installation designed to deliver 13MW for 100 electric buses of the Schiphol airport area (Figure 81).



Figure 81: Pantograph up IDIADA solution

Floor-mounted ACD is classified as Type C solution. In September 2019, Alstom presented in Malaga, Spain, the latests innovation of ground-based recharging systems – SRS dedicated to electric buses. It is equipped with a 200kW charger and is associated with a twelve-meter bus [56] (Figure 82).

Schunk has also presented a prototype of a retractable recharging station located in the pavement, with a docking module built into in the vehicle underbody permitting a high-power transfer of up to 1 MW [57] (Figure 83).



Figure 82: Floor mounted ACD Alstom solution

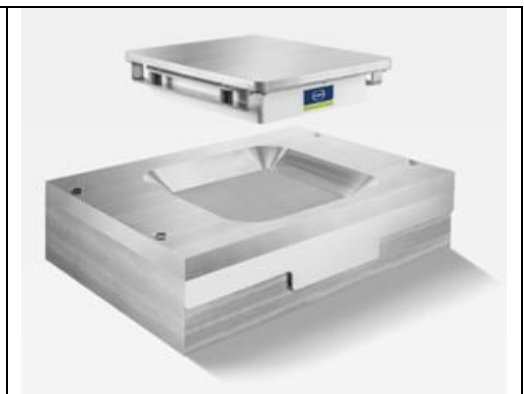

Figure 83: Schunk Smart Charging: Underbody Charger

4.1.4.3 In motion charging

Catenary

EVs can also be charged during driving using the dynamic charging methods. A clear example is the Dynamic catenary charging. The potential examples of charging infrastructure for long haul trucks are listed below with details about the implementation as well. More details are available in [58].

- **Overhead conductive:** In this type of charging power is continuously transferred from overhead lines to the vehicle through a pantograph. Overhead conductive charging is most suitable for trucks and buses that are high enough to reach the electric lines. The following pilot projects examples, are running nowadays:
 - **Siemens eHighway:** Siemens has implemented a 2km closed test track in Germany. Testing has been done with Scania trucks and demonstrated in 2016. This is an overhead catenary line. A demonstrator has been implemented in Sweden as well. [59]
 - **E16 Sandviken:** Since 2016, an electric road system was tested in Sandviken and Kungsgrden. It is now disassembled as per planning. The demonstration portion was two kilometers long and ran between Kungsgrden and Sandviken on the E16. The highway has been run by two trucks to see how well it performs in regular traffic and in various weather conditions. It has performed admirably, and Siemens and Scania have gained a wealth of information for future development. The project's expertise will now be gathered into a final report for submission to the Swedish Transport Administration. [60]
 - **ELISA – eHighway Hessen** [61] : The goal of ELISA is to evaluate the eHighway system utilizing economic, technological, ecological, and regulatory criteria in a realistic road and traffic operation environment. A main purpose of ELISA is to analyze the integration of this new infrastructure into real-life road and traffic operations, in addition to accumulating experience with the electric infrastructure and monitoring the handling of eHighway vehicles in forwarding firms. In May 2019 the first catenary wire truck started in real operation. Until the end of 2022, the logistics partners will collect and evaluate data. Once the first research findings are available, they will be published here: <https://ehighway.eu.hessen.de/node/7>
 - **eHighway SoCal** [62]: The project focused on erection of 1-mile catenary bi-directional infrastructure in Southern California, USA a power supply substation and integration of pantograph type current collectors into three different trucks which were intensely tested.
 - **FESH:** The eHighway Schleswig-Holstein (FESH) field test is a pilot project for electrically powered overhead line trucks. For this purpose, an overhead contact line system was set up on an approximately 2 x 5 km long test section on the federal autobahn 1 between Reinfeld and Lübeck (Germany) [63].
 - **eWayBW:** The eWayBW project is a test bed for electrically powered overhead line hybrid trucks. Two portions of the B 462 between Kuppenheim and Gernsbach-Obertsrot (Germany) will be electrified with overhead lines as part of a public test route. The operation of overhead line hybrid trucks will be investigated over a three-year test phase. The initiative will be accompanied by scientific study. The abbreviation "eHighway" refers to the technology that will be tested under real-world conditions by eWayBW. [64]

Conductive Power Transfer from Road

This is similar to overhead conductive technology except that power is transferred to the vehicle through rails embedded in or on top of the road surface. They are also referred to as Groundline / Third Rail.

- **Alstom ERS:** Since 2003, a ground level conductive system has been in service in Bordeaux city in France. This has been installed by Alstom and is called APS (Aesthetic Power Supply). Rails at ground level deliver power eliminating need for overhead catenary systems. [65]
- **Elonroad:** This solution consists of power receiver device with at least 3 contacts and the rail rises 5cm above ground level. Demonstration along a test track is ongoing in southern Sweden [66].



Figure 84 Elonroad implementation



Figure 85 Apparatus needed under the vehicle

- **Elways:** The rail solution from the company Elways has conductive surface inside small trenches on the road. A functioning demonstrator has been in operation since 2018 close to Arlanda airport, Sweden.

The details of existing catenary and ground rail systems is provided in Table 22.

Table 22: Details of the various charging infrastructure [16]

Name	Location	Solution	Start of vehicle operation	End
E16 Electric road	E16 in Region Gävleborg, Sweden	Overhead lines	2016	2020
SCAQMD	Los Angeles County, USA	Overhead lines	2017	2017
eRoadArlanda	Arlanda Airport, Sweden	Rails	2018	2019
ELISA	A 5, Germany	Overhead lines	2019	2022
FESH	A 1, Germany	Overhead lines	2019	2022
eWayBW	B 462, Germany	Overhead lines	2020	2023 ¹
Pre-commercial procurement by the Swedish Transport Administration	Not decided	Not decided, rail and wireless solutions are considered	2020 (estimated)	2022 (estimated)

Trolley buses

Trolley buses were a popular mode of transport a few decades ago with a maximum of 366 trolley systems operated in 1949. The number of trolley systems in the world today is 286. Trolleybus systems were closed as cars became more affordable and funding for these systems was reduced [67].

Efforts to bring trolleybuses into urban transportation are being made to as a part of reducing emission with cities. Several projects have been funded by the European union to research into trolleybus systems:

1. Trolley: 2.0 (2018 – 2020) (<https://www.trolleymotion.eu/trolley2-0/>)
2. ELIPTIC (2015 – 2018) (<https://eliptic-project.eu/>)
3. ACTUATE (2012 – 2015) (<http://www.actuate-ecodriving.eu/index.php?id=2>)
4. TROLLEY (2010 – 2013) (<http://www.trolley-project.eu/>)



Figure 86: Trolleybus poles (photo by TROLLEY project)

The significant differences to pantograph technology are the type of contact point to the overhead line (half-shell for trolley, line-shaped for pantograph) and the way of (re)establishing contact (significantly more difficult for trolley).

Today's trolleybuses can be considered a cross between a traditional trolleybus and a battery bus. During the mission today's trolleybus may charge its energy storage units under the overhead contact line of a trolleybus, allowing it to drive on both line portions with and without an overhead contact line. As a result, an electric urban bus system with overhead contact wires covering only 30 to 50 percent of the line can be implemented. [67]

Wireless Power Transfer (WPT)

Here power transfer takes place between coils embedded in the road and coils in the vehicle without any wires. The power from the grid is converted into high frequency AC power to create a magnetic field which is then picked up by the coils under the vehicle to produce voltage.

- **Seoul City Park On-line Electric Vehicle (OLEV)** – This is tram for visitors of Seoul city park. This implementation is out of KAIST university of South Korea. Sections of road are electrified, such that the tram can be charged while moving. It has been in operation since 2013 [68].
- **Primove Bombardier:** Bombardier has performed a demonstrator of its Primove wireless power transfer technology with a Scania truck on a closed test track in Mannheim, Germany.
- **FABRIC: FeAsiBility** analysis and development of on-Road charging solutions for future electric vehiCles (FABRIC) is a large EU project with the main challenge of reducing range anxiety of EV users and with the main objective of performing feasibility analysis of on-road charging technologies. The project has 3 demonstrators at testing sites in France, Italy and Sweden. The project ended in 2018, all the documents and conclusions can be found in [69].
- **WAVE:** Wireless Advanced Vehicle Electrification (WAVE), is a wireless charging company which has founded in 2011. They worked together with Antelope Transit Authority in electrifying their bus fleet and installed their wireless charging product at the bus stops. This bus system is claimed to be largest one in the US [70].
- **ASPIRE:** Advancing Sustainability through Powered Infrastructure for Roadway Electrification (ASPIRE) is an initiative of Utah State University in coloration with other universities and industry partners. They have a test track where charging and infrastructure studies are being made.
- **Electreon:** This is an Israeli company working on developing and implementing wireless electric road systems. They have built demonstrators in Tel Aviv, Gotland Island, Italy and Germany [71].

Table 23 Comparison of various In-motion charging products [72]

	IPT / Conductix Wampfler	Bombardier	KAIST OLEV	WAVE (USA)
Type	Static	Static/Dynamic	Static/Dynamic	Static
Power	Up to 180 kW	200 kW	Up to 180 kW	50
Max. Distance (cm)	5	6.5	Up to 20	17.8
Efficiency (%)	90	92	Up to 85	90

4.1.4.4 Opportunity charging

Opportunity charging means that the vehicle can charge during any opportunity available while the vehicle is stationary. This mainly includes charging with ACDs, wireless charging and flash charging.

Opportunity charging using ACD

In this concept, the vehicle connects to the grid with one of the ACD types (mentioned in section 4.1.1.3) during change of shifts or when the vehicle is stationary for a short amount of time when the vehicle is in operation. During these short breaks, the vehicle is charged at high power. The European Automobile manufacturers association provides the following recommendations for opportunity charging for electric buses:

1. Contact rails positioned on the roof above the front axle
2. Pantograph coming down from an overhead charging mast
3. Wi-Fi protocol for communication between vehicle and charging mast.

One of the demonstrators of opportunity charging with ACD is the implementation in Schiphol airport, Amsterdam (Figure 87).



Figure 87 450kW opportunity chargers at the schiphol airport [73]

The ACD chargers that are seen in *Figure 87* are 450kW type A ACDs which are on-route which are used by the buses for quick charge of around 10 minutes [73].

Another demonstrator of opportunity charging is the ABB Flash charging TOSA (Trolleybus Optimisation Système Alimentation) technology. The system is able to provide a 600kW charge for 20 seconds providing the vehicle with enough energy for a few kilometres. The manufacturers claim that the system has less than 1% losses [74]. *Figure 88* shows the system in operation.



Figure 88 Laser guided connector connecting to flash charging infrastructure

Opportunity charging using WPT

In this scenario, the vehicle is charged using wireless energy transfer while it is stationary. Such implementations have been made for light and heavy-duty vehicles. In *Figure 89*, we can see installation of a wireless charging pad at a bus station in Utah, USA. The implementation has been done by WAVE (Wireless Advanced Vehicle Electrification) company and operational since 2019. Wireless charging pads are deployed at various bus stops and the buses charge while passengers board/deboard the buses.



Figure 89 WAVE IPT wireless charger at a bus stop in Salt Lake City, Utah, USA [45]



Figure 90: Plugless Power wireless charger demonstrated with Nissan Leaf EV

In *Figure 90*, we can see a demonstration of wireless charging station for an electric car, the Nissan Leaf. The system can transfer up to 7.2 kW of power to the vehicle.

4.1.4.5 In-motion charging along with opportunity charging

A trolleybus when away from the overhead lines can charge itself using panto up ACD when stationary. Such a situation is shown in *Figure 91* where a battery-assisted trolleybus is charging its battery using a type 2 ACD at a bus stop which is outside the range of overhead lines.



Figure 91 Trolleybus charging with Type 2 ACD at a bus stop when away from overhead lines

4.1.5 Upcoming charging technologies

This section describes various technologies under development and under testing.

4.1.5.1 High power plug charging technology (MCS)

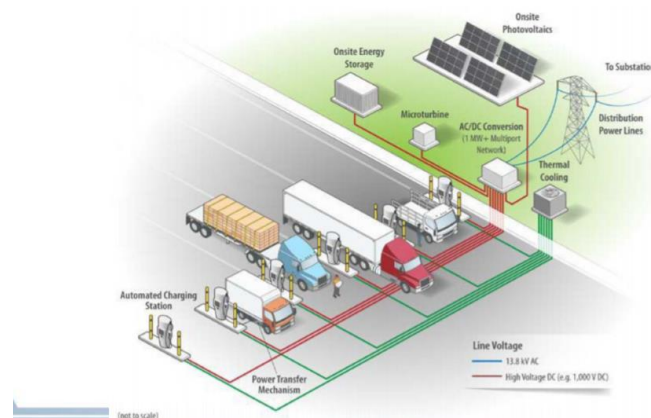

Figure 92. Highway MegaWatt chargers. [75]

To satisfy the increasing number of electric trucks and buses on roads a fast-charging technology is required. The CCS CharIN group is working on high power charging for electric commercial vehicles with a charging

capacity of one to three megawatts. CharIn has 106 core members which includes major European and American car manufacturers. The features of the megawatt charging system are defined as:

- Single conductive plug
- Max 1.250 Volt & 3.000 Ampere (DC)
- PLC + ISO/IEC 15118
- Touch Safe (UL2251)
- On-handle software-interpreted override switch
- Adheres to OSHA & ADA (& local equivalent) standards
- FCC Class A EMI (& local equivalent)
- Located on left side of the vehicle, roughly hip height
- Capable of being automated
- UL (NRTL) certified
- Cyber-Secure
- V2X (bi-directional)
- Downward compatibility to CCS 1 and CCS 2



Figure 93. CharIN Megawatt Charging System (MCS)

By using this charging method, a 500 kWh battery can be charged up to 80% SOC in 20 minutes. The details of the system are provided in Table 24.

Table 24.MCS general characteristics [76]

High Power Commercial Vehicle Charging Task Force (HPCVC)	
Max Power	1250 V x 3000 A = 3,75 MW
Range add/min charge	19,2 miles / 30,9 km
Communication Protocol	CAN or Ethernet (ISO 15118)
Location Used	US, Europe
Related Standards	none
Notes	Liquid Cooled

There are very few charging infrastructures deployed specifically for long-haul trucks. However, the charging stations of electric vehicles can be used to charge trucks as well.

4.1.6 Charging efficiencies

For the discussion of charging losses, it is first necessary to define the system boundaries. In the discussions on the general VECTO approach for xEV the possibilities for system boundaries as shown in *Figure 94* were identified. For VECTO and Regulation (EU) 2017/2400, it was defined that the system limit is to be set at "battery terminals", i.e. that only the battery charging losses are added to the simulated SOC-related electric energy consumption ("battery internal"). The main reason for this decision was the fact that charging losses upstream of the point "Battery terminals" can vary very individually depending on the use of the charging infrastructure (e.g.: which of several systems on the vehicle is used? which charging powers are applied?, does the customer operate his own off-board charging infrastructure?). The associated uncertainties and complexity would obscure the VECTO results for the actual vehicle efficiency. The detailed background to this decision is documented in the final report on the "VECTO Extension to Hybrids" project [77].

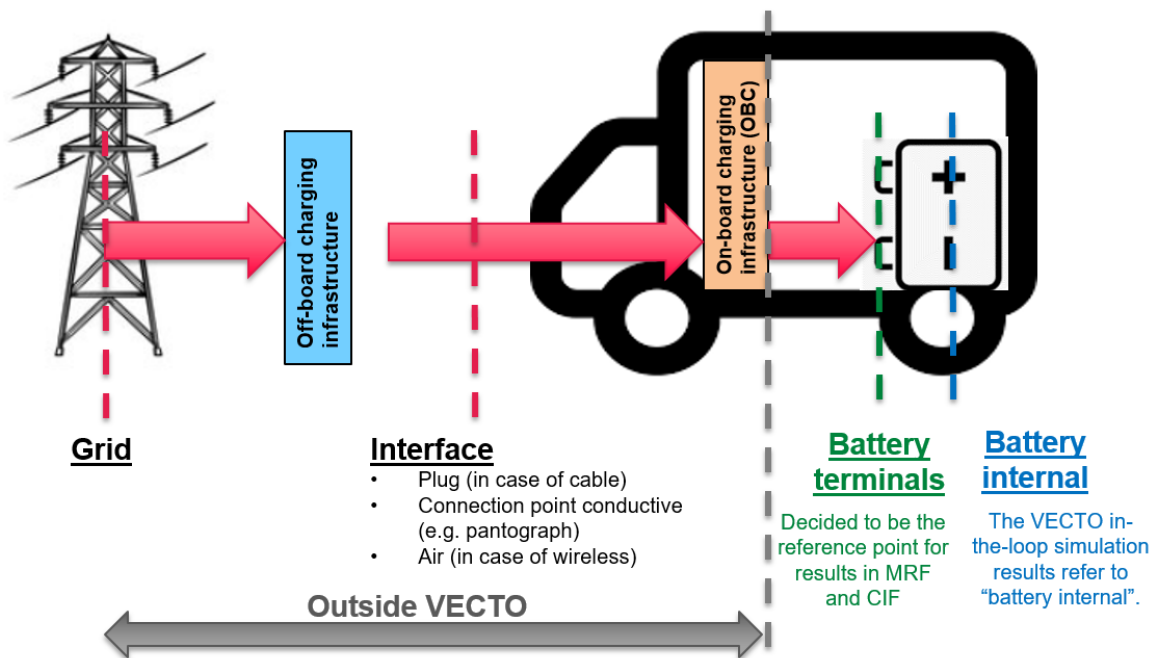

Figure 94: Schematic to explain efficiency boundary definitions

In the following, literature data for the charging losses not covered by VECTO, i.e. from the grid to battery terminals, are summarised. It should be noted that the values from the various literature sources are not based on uniform standards for determination (e.g. with regard to charging currents) and the values are therefore only comparable to a very limited extent.

From the data provided in Table 25 and Table 26, we get an overview of efficiencies of various implementations of all the charging methods. These data are from supplier datasheets, EU Funded project reports and other European projects executed over the years. They provide a range of values in some cases.

Table 25: Grid-to-battery efficiencies of charging methods – stationary

Demonstrators	Grid-to-Batt. nominal efficiency ranges	Source
Plug based		
AC Charging	--	Data required from manufacturers of On-board chargers
DC Charging	94-95%	Datasheets
ACDs		
ABB Pantograph solutions	90 – 97 %	PIARC report [78]
Heliox	<96 %	Datasheet
Furrer Frey	95 %	Datasheet
ABB Model HVC 150PD	94 %	Datasheet
Wireless		
Conductix Wampfler IPT	93 %	FABRIC report [69]
INTIS	88 – 93%	PIARC report [78]
Momentum charger	> 90 %	Manufacturer data
Plugless Power	87%	FABRIC report [69]
WiTricity	90 %	FABRIC report [69]

Table 26: Grid-to-battery efficiencies of charging methods – dynamic

Demonstrators	Grid-to-Batt. nominal efficiency ranges	Source
Overhead Catenary / Trolley		
Siemens e-highway	80 %	ENUBA 2 [79]
Trolleybus	80 %	[80]
Ground Rail System		
Elonroad	90 – 97 %	PIARC report [78]
Elways	82 – 95 %	PIARC report [78]
Wireless		
Electreon	90 %	PIARC report [78]

Demonstrators	Grid-to-Batt. nominal efficiency ranges	Source
OLEV, South Korea	71 – 91%	PIARC report [78]
Scania Bombardier Primove	68,8 – 90 %	PIARC report [78]
Vedecom Qualcomm HALO	80 %	PIARC report [78]

Qualitatively, the following can be said about the amount of charging losses:

- Charging systems provide maximum efficiency at rated power of the system. The efficiency rolls down as we move towards different power transfer rates.
- Higher the voltage of the powertrain architecture, lower currents are required to transfer the same amount power. Thus, vehicles with higher voltage systems have lower losses.
- Wireless systems have higher charging losses than direct contact systems, with losses increasing with poor vehicle-to-infrastructure alignment.
- AC charging (slow charging) requires an “On-Board charger” to convert AC to DC needed to charge the battery. This component determines the charging efficiency in this method of charging which in turn depends on its power electronic design and the semiconductor material used.
- At non-standard temperatures, the vehicle might use the charging power to bring the battery to suitable temperature before transferring power to it. This consumes additional charging power and longer charging duration.

4.2 VECTO calculation methods for vehicles with off-vehicle charging features

This section provides a complete description of the calculation methods of VECTO for vehicles with off-vehicle charging features as developed in this project and proposed for implementation in the 3rd amendment of Regulation (EU) 2017/2400.

4.2.1 General approach of vehicles with off-vehicle charging (OVC) capabilities

The starting point for the development of the approach was the discussion with Commission and stakeholders on where the reference point for the balancing of the electric energy consumption as calculated by VECTO should be. This definition is central to whether and how the influence of the different charging technologies is to be modelled. The conclusion from the discussions was that the most practical and reasonable solution is to choose the balancing point at “battery terminals”, i.e. not covering losses in the charging infrastructure. Detailed explanations on this definition and their justification are given in section 4.2.1.1. This basic approach was also adopted for the work on the VECTO methods for the 2nd amendment, which was not yet completed at that time.

For the consideration of in-motion charging technologies, another fundamental question to be clarified was whether driving with “direct feed” electrical energy supply should be simulated as a separate operating mode in VECTO (in addition to the “charge depleting” mode and, in the case of HEV, also the “charge sustaining” mode as already implemented in the 2nd amendment VECTO version). Here, a simple and robust method was

found that allows the calculations for charge depleting mode to be extended to include the in-motion charging feature by means of a special post processing. With this approach, unnecessarily detailed definitions are avoided (e.g. on which specific sections of a mission profile overhead lines are available). Furthermore the simulation time of VECTO does not increase compared to vehicles without the in-motion charging feature. This approach, together with the underlying basics for OVC vehicle simulation as already implemented in the 2nd amendment VECTO version, is described in section 4.2.1.2.

The third fundamental question to be clarified was whether and how the "electric ranges" as calculated by VECTO are influenced by the presence of in-motion charging features. It was found that also in the case of in-motion charging, it is meaningful to specify as electric range the distance that can be driven "from the battery", i.e. without using the charging infrastructure. It is this information which is essential for the vehicle user to assess the performance of the vehicle. These considerations are set out in detail in section 4.2.1.3.

The approaches listed above allow VECTO to deal with vehicles of different electric charging technologies in a very general and compact way.

4.2.1.1 External charging and reference point for electric energy balance

When quantifying the amount of electrical energy from an external source required for vehicle operation, two definitions need to be made to allow an unequivocal and comparable assessment between different vehicles:

1. The system boundaries for balancing the amount of electric energy, defining which losses in the chain of providing electric energy from an external source (i.e. the grid) to the vehicle should be considered for the final result.
2. A certain reference point where all the electric energy flows in the vehicle are balanced needs to be defined for correctly considering different paths over which the electric energy consumed by the vehicle during operation may be provided.

Above definitions are required for all vehicles which allow charging from an external source, i.e. OVC-HEVs, PEVs and, from the 3rd amendment on also OVC-FCHVs.

In principle, there are three reasonable locations where the system boundary for consideration of losses in providing electric energy from an external source could be defined:

- The connection point to the electric supply grid, taking all losses of required charging components i.e. off-board as well as on-board charging infrastructure and also internal losses of the battery into account.
- The interface to the charging port of the vehicle, taking only losses of required charging components inside of the vehicle and also internal losses of the battery into account.
- The battery terminals, taking only internal losses of the battery into account.

Figure 95 graphically illustrates the possible system boundaries. Based on arguments extensively discussed with stakeholders and listed in Table 27, the system boundaries were decided to be at "battery terminals". This reference point is used for both necessary definitions as outlined above.

"Battery internal" was not considered an appropriate location because:

- 1) It is not a generally valid reference point, as electrical energy from direct feed during driving as featured by in-motion charging technologies cannot be balanced there
- 2) The battery resistance is part of the VECTO input data anyway, and therefore the corresponding charging losses in the battery during external charging can be easily estimated by VECTO.

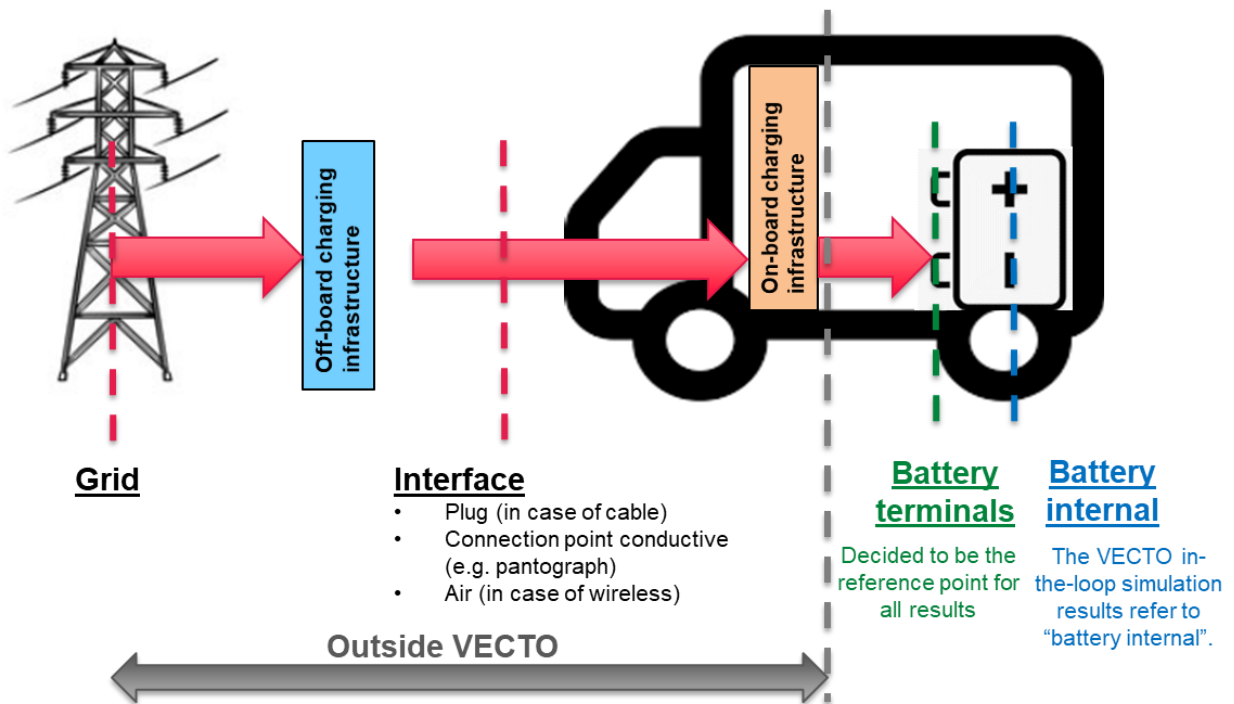

Figure 95: Location of system boundaries for external charging

Table 27: Pros and cons of different locations of system boundaries for external charging

Ref point	+ / o / -	Argument
Grid	+	This is what counts for society on a total energy consumption perspective
	o	Customer relevance (it depends on the business model of provider and where the meter for charging of fees is located)
	-	An additional industry sector would be touched by the Regulation and may discuss/question the generic parameters (net and charging point providers)
	-	Generic parameters for off-board charging infrastructure will be very uncertain and can not reflect specific solutions
	-	Makes system for a possible a future certification procedure much more complicated
	-	Results will be more complex to understand for customer
	+	This is what counts for society / COM on a vehicle optimisation perspective (a decision between infrastructure type e.g. catenary or not will anyway done based on the availability of the infrastructure)
Interface off/on-board	o	Might be what is relevant to the customer in part of the cases
	+	Most consistent option to TTW approach of VECTO in all other aspects
	+	Comparable to what is reported for LDV / WLTP
	-	Actual level of charging losses depends on individual influencing factors that are not known to VECTO (e.g. fast/slow charging behaviour).
	- -	Unclear how to deal with vehicles with multiple charging technologies (i.e. most of the vehicles). This will add artefacts and and put in question the VECTO results as a whole.
	o	The result does not cover the full picture relevant for customer and society
	+	Simple to handle and understand, no artefacts.
Battery terminals	+	Compatible with what is asked for in OBFCM
	+	Can be compared by the customer with the range relevant electric energy consumption display by the vehicle
	+	Clear system boundary to other (future) charging infrastructure standards

4.2.1.2 Calculation methods

As already mentioned above, xEV are simulated in VECTO in two dedicated operating modes:

- **Charge-depleting (CD) mode** for all xEV that can be externally charged with electric energy, i.e. OVC-HEV, PEV and from the 3rd amendment onwards FCHV with OVC feature
- **Charge-sustaining (CS) mode** for all hybrid vehicles - vehicles which can draw energy from a consumable fuel and from an electric energy source - i.e. specifically (ICE-)HEV and FCHV.

For OVC-HEV, which is a vehicle configuration for which both modes (CD and CS) apply, furthermore a weighted result from CD and CS mode is calculated to depict the average operation of the vehicle in real driving conditions.¹⁷

This basic approach is explained in detail below, followed by the necessary extensions to cover vehicles with in-motion charging capabilities.

Charge depleting and charge sustaining mode

In the **charge-depleting mode** the following conditions apply in VECTO:

- The vehicle is primarily - or even solely - powered by electric energy from the battery and the SOC may fluctuate but decreases on average while the vehicle is driven.
- To derive a representative value for energy consumption over a given mission, VECTO "artificially" keeps the SOC constant in the simulation, in the middle of the usable SOC range ("center SOC"). This is done to guarantee each vehicle being able to drive the complete cycle independent of its electric storage capacity.¹⁸ Furthermore, the constant SOC in the middle of the usable SOC range is representing best guess for average real-world usage since there is no explicit correlation between actual SOC level and distance in the VECTO mission profiles available (i.e. location of typical charging points in the mission).
- The electrical energy consumed in the cycle is accumulated in a separate counter, independent of the virtually constant SOC.
- For parallel HEV, the electric energy from the battery has priority and the ICE is only used in case the electric propulsion system cannot provide the demanded power.
- For serial HEV and FCHV, the electric energy from the battery has priority and the ICE or the FCS is only used in case the electric storage cannot provide the demanded electric propulsion power.
- Thus, in charge-depleting mode also a certain amount of fuel consumption could occur in addition to the electric energy consumed.
- The final electrical energy consumption as output by VECTO for the charge depleting mode for the reference point "battery terminals" is calculated from the energy consumption from the in-the-loop simulation referring to "battery internal" (SOC) level and the post-processing corrections for battery losses during external charging and the corrections for "direct feed" energy supply. The related formulas are described later in this section.

¹⁷ Whether a weighted result for OVC-FCHV should be provided by VECTO was still under discussion as this report was compiled. For propulsion systems that do not emit CO₂ emissions, this is not necessary (see section 3.6).

¹⁸ This ensures the comparability of the results for electrical energy consumption and ranges between all possible vehicle configurations. Otherwise, vehicles with a small battery would not be able to run the full cycle. Thus, the cycle specification implicitly depicted in the result would not be representative.

In the **charge-sustaining mode** the following conditions apply in VECTO:

- The vehicle is primarily powered by the ICE or the FCS and the energy stored in the battery may fluctuate but, on average, is maintained at a neutral charging balance level while the vehicle is driven.
- The applied HEV or FCHV control strategy and the accompanying post-processing method result in a neutral SOC over the cycle.¹⁹
- This results in the propulsion energy over the entire cycle being provided exclusively by the fuel and the electric energy consumption being zero by definition.

Weighting of results from the two operation modes

A weighting of the two modes is carried out in VECTO for vehicle architectures whose operation can in principle include both modes (CD and CS) and which use a fuel containing carbon. This is necessary to generate a single representative CO₂ value per mission profile and payload combination, which is required from the CO₂ standards as well providing a final results for CO₂ in the CoC. This weighting should reflect a typical usage pattern of the vehicle. For this purpose, a so-called utility factor (UF) is defined, which indicates the share of the total daily distance travelled in charge-depleting mode:

Utility factor = “daily distance which can be driven in CD mode” / “total daily driven distance”

The values for "total daily driven distance" are defined generically for each mission profile.

The value for “daily distance which can be driven in CD mode” is calculated from the total usable electric energy during the mission and the km-specific electrical energy consumption from the VECTO simulation.

For the total usable electric energy during the mission the following electric energy sources are considered:

- (1) Useable energy in the battery at the start of mission
 - For this purpose, the usable capacity of the battery is used in the calculations, which is further reduced by a real world usage factor „RF_{StartSOC}“ smaller than 1 reflecting the average real world charging behaviour, i.e. in reality the battery might not always fully charged at the beginning of a mission.
- (2) Energy that is recharged into the battery by stationary charging at certain events during the mission
 - The available energy is calculated from tabulated values depending on vehicle group and mission profile. The calculations consider also the limitations by the actual usable capacity of the battery.
 - The following tabulated values define the following parameters influencing the amount of available energy:
 - Number of charging events
 - Duration of charging events
 - Available charging power from infrastructure (which is further limited in the calculation by the maximum vehicle capabilities)
 - Real world usage factor for stationary charging „RF_{StatCharge}“ smaller than 1 reflecting the real world charging behaviour (i.e. in reality the battery is not fully charged at each charging opportunity and not each potential charging opportunity is actually used)

¹⁹ The control strategies for P-HEV and S-HEV are described in [44]. The control strategy for FCHV is described in section 3.2.3.4.

(3) Electrical energy from in-motion charging (only in case the vehicle has such a feature) supplied in two different ways:

- Direct feed of electric energy

For this purpose, generic factors are included in the model as a function of the in-motion charging technology, vehicle group and mission profile, indicating how large the share of the cycle distance is with the corresponding infrastructure.

- Charging of battery during driving

This form of supply is represented in the model by a generic percentage of usable battery capacity that is charged during driving under in-motion charging infrastructure.

Based on this data, the UF can be calculated for each mission profile and payload combination.

The final results for a specific mission and payload combination weighted for charge-depleting and the charge-sustaining mode then are determined as follows:

$$RES_{weighted} = UF \times RES_{CD} + (1-UF) \times RES_{CS}$$

where:

UF utility factor

RES_{CD} result in charge-depleting mode

RES_{CS} result in charge-sustaining mode

The term "result" in this context applies to fuel consumption, CO₂ emissions and electric energy consumption.

The calculations including all proposed generic parameters presented in the stakeholder meetings are documented in Excel `Task3_Masterexcel_OVC_IMC.xlsx` including sample calculations. The new generic parameters introduced in this project that are required for vehicles with in-motion charging are reasoned in section 4.2.2.

Calculation of electric energy consumption at battery terminals for the charge depleting mode

As already mentioned above, the electrical energy consumption in charge depleting mode shall be determined at the location "battery terminals". At this virtual point, all external electrical energy can be balanced, both electrical energy that is temporarily stored in the battery and electrical energy that is directly consumed ("direct feed") in the case of vehicles with in-motion charging capabilities (Figure 96).

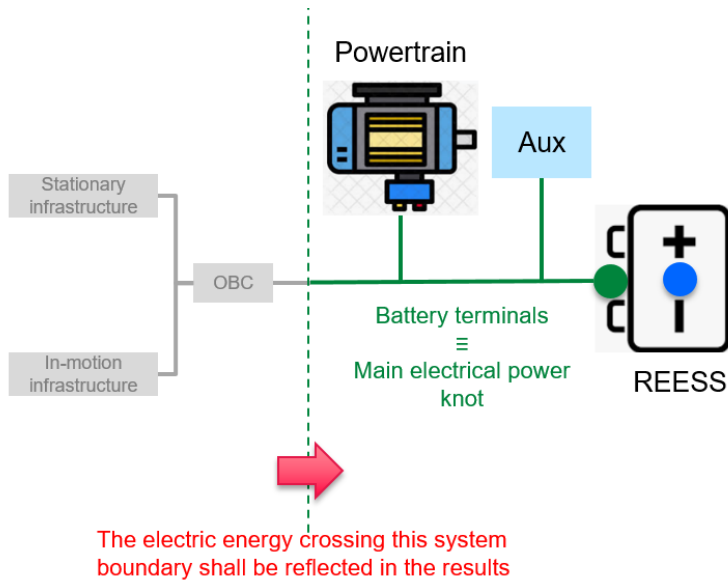

Figure 96: Balancing of electric energies in the charge depleting mode

For this purpose, the electrical energy consumption, e.g. in [kWh/km], determined in the VECTO in-the-loop simulation at SOC level (location blue dot in Figure 96) needs to be converted to "battery terminals" (location green dot in Figure 96) by means of post-processing. Two basic corrections have to be made:

- 1) For the part of the electrical energy from the grid that is actually first charged into the battery, the losses in the battery during external charging are to be added:

$$EC_{el,terminal} = EC_{el,SOC} / \eta_{bat}$$

- 2) For the part of the electrical energy which is actually available from in-motion charging for direct feed of the powertrain and other consumers, the discharge losses of the battery included in the in-the-loop simulation (which do in reality not occur with direct feed) need to be calculated out again:

$$EC_{el,terminal} = EC_{el,SOC} \times \eta_{bat}$$

In order to be able to make these corrections in VECTO in post-processing, it needs to be assumed that in mission profiles with in-motion charging infrastructure, the energy consumption on these sections does not differ from the energy consumption on the rest of the route. In this way, a general formula can be written for calculating the electrical energy consumption at battery terminals in the charge depleting mode:

$$EC_{el,terminal} = EC_{el,SOC} \cdot \left(S_{bat} \cdot \frac{1}{\eta_{bat(1)}} + S_{dir} \cdot \eta_{bat(2)} \right)$$

Where:

S_{bat} Share of electric energy from grid first charged into battery

S_{dir} Share of electric energy from grid used for direct feed

$\eta_{bat(1)}$... Eta_battery, average charging efficiency when charging from external sources

$\eta_{bat(2)}$... Eta_battery, average discharging efficiency during driving

The two battery efficiencies above are calculated by VECTO as follows:

1. Average charging efficiency when charging from external $\eta_{bat(1)}$

The average charging efficiency is determined by taking different charging generic scenarios into account:

a. Overnight charging in depot

Here, the duration of the charging event is assumed to be rather long leading to a lower level of charging power which results in lower charging losses. The charging power level is generically defined by dividing the usable energy content of the battery in kWh by a duration of 6 hours, but applying a minimum power of 10 kW.

b. Stationary charging during mission

Here, the generic level of charging power is taken from tabulated values depending on vehicle group and mission profile which are the same data as used for the determination of the utility factor. These generic power levels are limited with the maximum stationary charging power declared as VECTO input for OVC-HEV.

c. In-motion charging SOC lift

Here, generic levels of charging power are assumed to be 100 kW for heavy lorries and coaches as well as 30 kW for city buses.

Based on these different levels of charging power, the respective charging efficiencies are calculated for each charging scenario. The individual charging efficiencies are then aggregated into one single value of $\eta_{bat(1)}$ by computing a weighted average value based on the individual shares of energy recharged into the battery for each scenario.

2. Average discharging efficiency during driving $\eta_{bat(2)}$

In order to correct for the overestimated discharge losses of the battery in the in-the-loop simulation which do not occur in reality due to the direct feed of propulsion energy, the average discharging efficiency needs to be taken into account as relevant influencing variable. This quantity can be determined from the VECTO results calculated for the VSUM file by computing the ratio of total discharged energy at the battery system terminals over the total discharged energy battery internally (i.e. from the ideal voltage source of the loss free battery) as given by the following equation:

$$\eta_{bat(2)} = E_REESS_T_dischg / E_REESS_int_dischg$$

where:

$E_REESS_T_dischg$ Discharging power at battery system terminals integrated over the complete cycle

$E_REESS_int_dischg$ Battery internal discharging power integrated over the complete cycle

S_{dir} in the formula above is calculated as the ratio of electric energy provided by direct feed over the electric energy required for the daily specific mileage (i.e. total daily driven distance defined generically for each mission profile). S_{bat} is the share of the total electric energy demand to be buffered in the battery, which is defined as follows: $S_{bat} = 1 - S_{dir}$.

Example calculations for this can be found in `Task3_Masterexcel_OVC_IMC.xlsx`.

4.2.1.3 Electric ranges

Task 3 should also investigate the impact of different charging technologies on the electric ranges to be calculated by VECTO. As described in the introduction to this section, the main insight from the work was that the relevant result for the customer is the operating range of the vehicle completely decoupled from any charging, i.e. independent of the charging technology. Where charging technologies and the associated infrastructure availability do have an influence is the "utility factor" calculated internally by VECTO, which is required for the weighting of the results from the CD and CS modes.

All details on the ranges and any dependencies on charging technologies are given in Table 28.

Table 28: Characteristic electric ranges in VECTO

Electric range	Definition and further explanations	Used for	Specific charging technology to be considered in the determination?
Actual charge depleting range (R_{CDA})	<p>The range that can be driven in charge depleting mode based on the usable amount of REESS energy, without any interim charging.</p> <p>as defined by Point 2(1) of Annex IV to Regulation (EU) 2017/2400</p>	<p>MRF, CIF</p> <p>Main relevant information for customer (range from usable battery capacity, w/o additional infrastructure)</p>	No
Equivalent all electric range (EAER)	<p>The part of the actual charge depleting range that can be attributed to the use of electric energy from the REESS, i.e. without any energy provided by the non-electric propulsion energy storage system.</p> <p>as defined by Point 2(2) of Annex IV to Regulation (EU) 2017/2400</p> <p>The EAER is calculated from the R_{CDA} multiplied by the proportion of fuel consumption in the CD mode in relation to the fuel consumption in the CS mode. Thus, the EAER differs from the R_{CDA} only for vehicles that have fuel consumption in addition to electrical energy in charge depleting mode (e.g. may be the case for OVC-HEV).</p>	<p>MRF, CIF</p> <p>Only an interim result for ZCER below.</p>	No

Electric range	Definition and further explanations	Used for	Specific charging technology to be considered in the determination?
Zero CO₂ emissions range (ZCER)	<p>The range that can be attributed to energy provided by propulsion energy storage systems considered with zero CO₂ impact.</p> <p>as defined by Point 2(3) of Annex IV to Regulation (EU) 2017/2400</p> <p>For calculating ZCER, the "hydrogen range" (H₂R) is added to the EAER for vehicles using H₂ (FCHV and H₂ ICE). H₂R is calculated from the usable H₂ storage capacity (value in kg) and the H₂ consumption of the vehicle in CS mode (value in kg/km). Details see section 3.4.</p>	<p>MRF, CIF</p> <p>This value was introduced in Regulation (EU) 2017/2400 and thus VECTO as an indicator for the classification of a vehicle in the CO₂ standard ("operational range").</p>	<p>No.</p> <p>However, it may be important to consider in the CO₂ standards that a vehicle with an in-motion charging feature may well be able to travel further than specified by the ZCER with zero emission impact if the corresponding in-motion charging infrastructure is in place.</p>
Electric range for utility factor calculation	<p>Daily distance which can be driven in charge depleting mode based on the total usable electric energy during the mission which results from the following sources:</p> <ol style="list-style-type: none"> (1) Useable energy in the battery at the start of mission (2) Energy that is recharged into the battery by stationary charging at certain events during the mission (3) Electrical energy from in-motion charging 	<p>Interim result in VECTO to determine the utility factor and to generate a weighted result from CD and CS mode.</p> <p>The details of the calculations are explained in section 4.2.1.2.</p>	<p>Yes</p>

4.2.2 Specific considerations for vehicles with in-motion charging technologies

This section describes the necessary considerations that have to be made apart from the calculation methods already described in the previous section in order to take vehicles with in-motion charging technologies into account. These include:

- Necessary definitions or additions to the Annexes
- Suggestions for generic parameters in the calculations.

The first step is to define "in-motion charging technology". Since no corresponding term is known in the existing regulations, the following definition is proposed:

“Charging technology that enables the vehicle to be connected to an external electrical power supply while in motion during a mission, providing direct power to the vehicle's propulsion and/or auxiliary systems and/or charging the batteries.”

4.2.2.1 Which specific technologies should be covered by the 3rd amendment?

The overview of the different charging systems in Figure 61 on page 101 distinguishes between the three basic in-motion charging technologies: "Overhead", "Wireless Power Transfer" as well as "Ground-Line". The most common technology among them is "Overhead", with the two concrete sub-technologies "pantograph" (as they are currently being built in several European countries as "eHighway" routes) and the "trolley" technology as established for city buses. This results in the following technology differentiation for VECTO, which is to be declared for in-motion charging vehicles in the vehicle input (Table 29):

Table 29: In-motion charging technologies for the 3rd amendment

In-motion charging "technology" in the VECTO input	Relevance			Proposal for definition in Regulation (EU) 2017/2400
	Heavy lorries	Heavy buses	Medium lorries	
Overhead pantograph	Yes	Yes	No	Vehicle equipped with overhead pantograph for connection with overhead catenary infrastructure as regulated by <i>standard tbd</i> ² , and which is not overhead trolley.
Overhead trolley	No	Yes	No	Vehicle equipped with poles for connection with overhead catenary infrastructure as regulated in Annex 12 to UN Regulation 107 revision 8.
Ground-rail	Yes ¹	Yes ¹	Yes ¹	Charging technology that conductively transfers the electrical energy to the vehicle through rails embedded in or on top of the road surface.
Wireless	Yes ¹	Yes ¹	Yes ¹	Charging technology that inductively transfers the electrical energy to the vehicle through devices embedded in or on top of the road surface providing magnetic fields as they are specified IEC 61980.
¹ Potential niche applications are conceivable. See below for limitations in the coverage of VECTO. ² Reference to the standard currently being developed still to be inserted				

A finer differentiation according to additional sub-technologies is not recommended for VECTO, as any technology differentiation in the model only has an effect on the allocation of generic infrastructure availability, for which no detailed data are available anyway (see section 4.2.2.2).

For ground-rail and wireless, it is assumed that only small series of vehicles for very local applications will use this technology. Accordingly, any assumptions about their use are uncertain. Therefore, the following approach is proposed for these two technologies:

- The 3rd amendment should cover PEVs with ground-line and wireless in-motion charging by Article 9 (i.e. specifically simulate electrical energy consumption with VECTO). For PEVs the uncertainty on the electrical energy consumption due to the generic definitions on share of driving with direct feed is very small.²⁰
- The 3rd amendment is recommended to exempt OVC HEVs with ground-line and wireless in-motion charging from Article 9. For these vehicles, the CO₂ emission level depends directly on the necessary assumptions about infrastructure availability, which must be made without any concrete knowledge of the actual application. Since such vehicles will certainly fill at most a small niche, the exemption seems the most obvious option.

4.2.2.2 Generic assumptions on in-motion charging infrastructure availability during mission

The proposed generic shares of the in-motion charging infrastructure in the VECTO mission profiles are discussed below. The values are relevant in the VECTO calculations via the quantity S_{dir} (see section 4.2.1.2). In defining these shares, it is important to bear in mind that the values do not depend primarily on the general availability of infrastructure, but rather on the specific use of the vehicle by the customer. This means that it can be assumed that, for example, a vehicle with a pantograph will only be bought by customers whose preferred routes are on electrified routes.

As already mentioned before, the related generic assumptions have a very low impact on the results for PEV as only slightly different energy flows and possibly a different air drag in “up” position needs to be considered. However, for OVC-HEVs, like the prototype vehicles as currently seen on eHighways, those assumptions are crucial for the final result and final CO₂ via the “utility factor”

Overhead-Pantograph

Table 30 shows the proposed proportions of catenary infrastructure for vehicles with overhead pantograph. The following considerations have been taken into account in the figures:

Medium lorries: Pantograph not a relevant technology

Heavy lorries: It is assumed that 50% of the “motorway” share as defined for the mission profiles²¹ is covered by the catenary line. This 50% includes the following influencing factors:

- For “eHighway” routes, the target is to electrify approx. 80% of the route (information from Siemens and Scania).
- In real operation, access motorways to the eHighways will also be used.
- In some applications / cases, the vehicles will also have to be used on other motorways

²⁰ The “basic consumption” of electrical energy at SOC level is always the same. There is only an influence on the charging losses in the battery during external charging - losses that do not occur in direct feed operation with in-motion charging.

²¹ These motorway shares are: Long haul: 100%, Regional delivery: 67%, Coach: 56%

Heavy buses: In contrast to trolley applications (see below), it is assumed that catenary lines are installed only on sensitive sections to reduce required battery size. Here 30% is assumed. The 30% also matches approx. 50% of motorway sections in the coach cycle, which results in a uniform value for all bus mission profiles.

Table 30: Generic infrastructure availability - Catenary

Vehicle group	Share of distance of total mission where in-motion charging infrastructure is available -									
	Long haul	Regional delivery	Urban delivery	Municipal	Construction	Heavy Urban	Urban	Sub-urban	Inter-urban	Coach
53	---	0.00	0.00	---	---	---	---	---	---	---
54	---	0.00	0.00	---	---	---	---	---	---	---
1s	---	0.34	0.00	---	---	---	---	---	---	---
1	---	0.34	0.00	---	---	---	---	---	---	---
2	0.50	0.34	0.00	---	---	---	---	---	---	---
3	---	0.34	0.00	---	---	---	---	---	---	---
4	0.50	0.34	0.00	0.00	0.00	---	---	---	---	---
5	0.50	0.34	0.00	---	0.00	---	---	---	---	---
9	0.50	0.34	---	0.00	0.00	---	---	---	---	---
10	0.50	0.34	---	---	0.00	---	---	---	---	---
11	0.50	0.34	---	0.00	0.00	---	---	---	---	---
12	0.50	0.34	---	---	0.00	---	---	---	---	---
16	---	---	---	---	0.00	---	---	---	---	---
31	---	---	---	---	---	0.30	0.30	0.30	0.30	---
32	---	---	---	---	---	---	---	---	0.30	0.30
33	---	---	---	---	---	0.30	0.30	0.30	0.30	---
34	---	---	---	---	---	---	---	---	0.30	0.30
35	---	---	---	---	---	0.30	0.30	0.30	0.30	---
36	---	---	---	---	---	---	---	---	0.30	0.30
37	---	---	---	---	---	0.30	0.30	0.30	0.30	---
38	---	---	---	---	---	---	---	---	0.30	0.30
39	---	---	---	---	---	0.30	0.30	0.30	0.30	---
40	---	---	---	---	---	---	---	---	0.30	0.30

Trolley

Table 30 shows the proposed proportions of trolley overhead line infrastructure. The following considerations have been taken into account in the figures:

Medium lorries and heavy lorries: Trolley not a relevant technology

Heavy buses: In the case of urban buses, the traditional overhead line system cover almost 100% of the routes operated by trolley buses are equipped with overhead lines. For newly built infrastructure, solutions are also being implemented that provide approx. 20% to 40% of the route with overhead lines and where the vehicles are equipped with correspondingly large batteries. For VECTO, 80% infrastructure coverage is proposed for urban bus applications.

Trolley technology is usually limited to speeds below 70 km/h. This results in only a low potential for trolley infrastructure for the interurban mission profile, which is assumed to be 20%. For coach applications, trolley infrastructure does not appear to be relevant (0%).

Table 31: Generic infrastructure availability - Trolley

Vehicle group	Share of distance of total mission where in-motion charging infrastructure is available -									
	Long haul	Regional delivery	Urban delivery	Municipal	Construction	Heavy Urban	Urban	Sub-urban	Inter-urban	Coach
53	---	0.00	0.00	---	---	---	---	---	---	---
54	---	0.00	0.00	---	---	---	---	---	---	---
1s	---	0.00	0.00	---	---	---	---	---	---	---
1	---	0.00	0.00	---	---	---	---	---	---	---
2	0.00	0.00	0.00	---	---	---	---	---	---	---
3	---	0.00	0.00	---	---	---	---	---	---	---
4	0.00	0.00	0.00	0.00	0.00	---	---	---	---	---
5	0.00	0.00	0.00	---	0.00	---	---	---	---	---
9	0.00	0.00	---	0.00	0.00	---	---	---	---	---
10	0.00	0.00	---	---	0.00	---	---	---	---	---
11	0.00	0.00	---	0.00	0.00	---	---	---	---	---
12	0.00	0.00	---	---	0.00	---	---	---	---	---
16	---	---	---	---	0.00	---	---	---	---	---
31	---	---	---	---	---	0.80	0.80	0.80	0.20	---
32	---	---	---	---	---	---	---	---	0.20	0.00
33	---	---	---	---	---	0.80	0.80	0.80	0.20	---
34	---	---	---	---	---	---	---	---	0.20	0.00
35	---	---	---	---	---	0.80	0.80	0.80	0.20	---
36	---	---	---	---	---	---	---	---	0.20	0.00
37	---	---	---	---	---	0.80	0.80	0.80	0.20	---
38	---	---	---	---	---	---	---	---	0.20	0.00
39	---	---	---	---	---	0.80	0.80	0.80	0.20	---
40	---	---	---	---	---	---	---	---	0.20	0.00

Ground rail and wireless

With regard to these two technologies in the context of in-motion charging, only very local infrastructures are to be expected. This means that all mission profiles driven over long distances or alternating routes are not suitable. For the remaining mission profiles, an infrastructure coverage of 50% is assumed (Table 32).

Table 32: Generic infrastructure availability - Ground rail and wireless

Vehicle group	Share of distance of total mission where in-motion charging infrastructure is available -									
	Long haul	Regional delivery	Urban delivery	Municipal	Construction	Heavy Urban	Urban	Sub-urban	Inter-urban	Coach
53	---	0.00	0.50	---	---	---	---	---	---	---
54	---	0.00	0.50	---	---	---	---	---	---	---
1s	---	0.00	0.50	---	---	---	---	---	---	---
1	---	0.00	0.50	---	---	---	---	---	---	---
2	0.00	0.00	0.50	---	---	---	---	---	---	---
3	---	0.00	0.50	---	---	---	---	---	---	---
4	0.00	0.00	0.50	0.50	0.00	---	---	---	---	---
5	0.00	0.00	0.50	---	0.00	---	---	---	---	---

Vehicle group	Share of distance of total mission where in-motion charging infrastructure is available -									
	Long haul	Regional delivery	Urban delivery	Municipal	Construction	Heavy Urban	Urban	Sub-urban	Inter-urban	Coach
9	0.00	0.00	---	0.50	0.00	---	---	---	---	---
10	0.00	0.00	---	---	0.00	---	---	---	---	---
11	0.00	0.00	---	0.50	0.00	---	---	---	---	---
12	0.00	0.00	---	---	0.00	---	---	---	---	---
16	---	---	---	---	0.00	---	---	---	---	---
31	---	---	---	---	---	0.50	0.50	0.50	0.00	---
32	---	---	---	---	---	---	---	---	0.00	0.00
33	---	---	---	---	---	0.50	0.50	0.50	0.00	---
34	---	---	---	---	---	---	---	---	0.00	0.00
35	---	---	---	---	---	0.50	0.50	0.50	0.00	---
36	---	---	---	---	---	---	---	---	0.00	0.00
37	---	---	---	---	---	0.50	0.50	0.50	0.00	---
38	---	---	---	---	---	---	---	---	0.00	0.00
39	---	---	---	---	---	0.50	0.50	0.50	0.00	---
40	---	---	---	---	---	---	---	---	0.00	0.00

4.2.2.3 Air drag influences of vehicle components related to in-motion charging

Considerations regarding air drag influence of vehicle components related to in-motion charging need to be carried out on two levels:

- I. Should the influence of in-motion charging components (e.g. pantograph, trolley poles) be considered in the simulation in VECTO, and if so how?
- II. Which additions are necessary in Annex VIII on air drag certification? Additions in Annex VIII are required also in case the answer to I. is no, as:
 - Provisions are required how to handle the moveable devices (e.g. pantograph, trolley poles) during the Constant Speed Test (CST)
 - Provisions for allocation of vehicles with such devices to specific air drag families are required.

Approach for pantographs

Since the pantograph has a significant C_dx_A influence and is in "up" position also at high driving speeds, the effect on the drag and thus on the total energy consumption of the vehicle needs to be taken into account in VECTO. The following approach is proposed:

- Annex VIII – CST:
 - Air drag shall be determined in pantograph position "down" only.²²

²² An separate air drag certification with pantograph in "up" position would be very complex to define, e.g. what exact height should the pantograph have in the CST (in real operation there are different heights due to the course of the catenary) and how to consider crosswind in the measurement. Thus this approach is assessed to be disproportional, as also the share of travel time in the up position in real operation is not known exactly.

- It is free to the manufacturer if a vehicle configuration with pantograph is put into a separate air drag family or not taking into account all provisions already defined for the air drag family concept.
- VECTO simulation:
 - A generic ΔC_{dxA} is defined for pantograph position „up“, which is defined with +0.6m².
 - In the simulations this generic ΔC_{dxA} is added to the certified C_{dxA} in the sections identified as “motorway” taking into account the catenary infrastructure availability share (e.g. 0.5 in the long haul cycle).

The value of 0.6 m² for the above mentioned ΔC_{dxA} was derived by TUG from [81].

Approach for trolley poles

As mentioned above, trolley poles are only used on buses and in mission profiles in the lower and medium speed range (< 60 km/h). Trolley poles are furthermore considered to have much lower ΔC_{dxA} influence than a pantograph. Thus the following approach is proposed:

- The air drag influence of trolley poles is not considered by VECTO.
- For heavy buses subject to air drag measurement (only the groups operating on interurban and coach cycle) it is to be specified that trolley poles and the related equipment shall not be considered in CST.

Approach for ground-rail and wireless technologies

The influence of devices related to ground-rail and wireless in-motion charging on the drag coefficient is only slight, as the infrastructure is located under the vehicle. Furthermore, these technologies are only relevant for applications with low driving speeds. Therefore, the influence in VECTO can be neglected.

Resulting required modifications in Annex VIII

The approaches described here result in the following Amendments to Annex VIII:

Appendix 5: Family concepts

Addition a new sub-point 4.4 for vehicles with in-motion charging technologies:

- For vehicles equipped with pantographs, these shall be represented in the configuration with pantograph in the "down" position.
- For vehicles with trolley poles or devices related to ground-rail and wireless in-motion charging, the vehicle may be represented without the corresponding attachments²³.

Point 3.3 in main part of Annex VIII: Installation requirements

If vehicles with in-motion charging technologies are measured (for provisions see point 4.4 of Appendix 5), they must be fixed in the retracted or "down" position.

²³ If the vehicle is only available in this version, it should of course also be allowed to be tested and represented in this configuration.

4.2.3 Proposed extensions in the 3rd Amendment with regard to stationary charging technologies

With the decision to place the 'balancing point' for electrical energy consumption at the battery terminals (and thus to disregard the electrical losses in the on-board and off-board charging), there is only a limited need to expand the corresponding points in Annex III for the drafting of the 3rd Amendment. The recommended extensions are related to Parameter P401 ("Max. charging power"):

- It shall be clarified that this value shall refer to a power level which can be maintained for a time of at least 20 minutes
- It shall be clarified that this values shall only refer to the stationary charging and that if several stationary charging technologies are present on the vehicle that the overall maximum power shall be declared
- This input value needs to be provided for PEV as well (not only OVC-HEV as currently the case), so that the battery losses during external charging can also be calculated for these vehicles.

What could yet be discussed is whether also for stationary charging the basic technology (e.g. 'Plug-in via cable', 'Conductive with automated connection device' and 'Wireless') should also be entered in VECTO. Although the input would currently have no effect on the VECTO result, it would make it possible in the future to collect data on the charging technologies in monitoring and reporting and possibly make corresponding additions to VECTO (e.g. applying other usage patterns for the utility factor for plug-in hybrids) in later amendments.

4.3 VECTO Implementation

The methods described in section 4.2 are implemented in a prototype version of VECTO. According to the developed methodology, the new functions practically only concern the modelling of in-motion charging features.²⁴ The implementation is designed as follows:

Engineering mode (ENG)

The implementation shall give the expert user the possibility to test all possible technologies and scenarios (e.g. for infrastructure availability).

For this purpose, the following parameters are read in at vehicle level via GUI or json file for all OVC xEV architectures:

- In-motion charging feature [yes/no]
- Share of in-motion charging infrastructure availability on total mission distance [-]
- Delta CdxA with active in-motion charging feature [m²]
- In-motion charging infrastructure only available on motorway sections [yes/no]²⁵

²⁴ With regard to the extension of the VECTO methodology regarding stationary charging technologies, only minimal changes result, i.e. the consideration of the maximum charging power in the calculation of battery losses during external charging as well as the passing through of information on the available charging technologies in the XML-driven Declaration mode, see section 4.2.3.

²⁵ For pantographs on lorries and coaches – contrary to city buses – the associated infrastructure is only considered on motorways. Accordingly, in the simulation, the delta CdxA is only added to these sections marked "motorway" in the cycle,

In the "in-the-loop" simulation, the CdxA value is modified accordingly (either in the entire cycle or only in the motorway part considering the infrastructure availability factor).

Declaration mode (DECL)

In the prototype for the Declaration mode, an existing in-motion charging feature is read in via the GUI or json files according to the technologies defined in section 4.2.2 (Overhead pantograph, Overhead trolley, Ground-rail, Wireless). In the calculations, this technology is then linked to the corresponding generically defined parameters and the in-the-loop simulation and all post-processing calculations documented in `Task3_Masterexcel_OVC_IMC.xlsx` are carried out. For the simulations in the Charge Sustaining mode, it should be noted that the $\Delta CdxA$ defined for pantograph position „up” is not added to the vehicles air drag, as in this operation mode per definition the pantograph is in “down” position. The prototype implementation could only be carried out for heavy lorries, as there is no json-driven Declaration mode for heavy buses.

multiplied by the availability factor: “Share of in-motion charging infrastructure availability on total mission distance” / “share motorway on total cycle distance”.

5 Task 4: Platooning - Automated/Connected vehicles

Platooning is based on the operation of several heavy vehicles driving one after the other, which are virtually connected and guided by a guide vehicle in longitudinal and lateral direction. Task 4 assessed not only platooning, but also other currently available technological solutions for connected vehicles and their potential impact on CO₂ emissions, energy and fuel consumption for heavy-duty vehicles (HGVs), and identified options for their future consideration in VECTO.

Task 4 is divided into four subtasks:

- Subtask 4.1: Review the state of the art of the technologies and influence of vehicle operation
- Subtask 4.2: Environmental, economic, and social impacts
- Subtask 4.3: Feasibility assessment
- Subtask 4.4: Options for implementation in VECTO

Task 4 was being elaborated by TUG in close cooperation with IDIADA.

5.1 Subtask 4.1: Review the state of the art of the technologies and influence of vehicle operation

This section is structured as follows:

- Overview of European research projects relevant to the topic (section 5.1.1)
- Overview of thematically relevant European regulations and discussion groups (section 5.1.2)
- List of technologies with a description of how they work and how they affect vehicle operation (section 5.1.3).

5.1.1 European projects

SARTRE and **COMPANION** were the first projects launched by the European Commission exploring the platooning concept. SARTRE project main objective was to validate the technology. Once it was validated, COMPANION projects aimed to prove the creation, coordination, and operation of such platoons.

ENSEMBLE project intended to pave the way for the adoption of multi-brand truck platooning in order to improve fuel economy, traffic safety and platoon performance.

Another project was **AEROFLEX**, from the H2020 EU Research and Innovative program. AEROFLEX project developed new concepts and architectures for trucks, looking for CO₂ reduction, comfort, safety and energy efficiency improvement.

Furthermore all other relevant projects are mentioned in this chapter as **HFAUTO**, **ROADART**, **Connecting Austria**, **EDDI** and **Helm UK**.

In this section the respective project settings are described, the next section (5.2) deals with the results relevant for this work.

5.1.1.1 SARTRE [82]

The acronym for SARTRE is Safe Road Trains for the Environment; developing strategies and technologies to allow vehicle platoons to operate on normal public highways with significant environmental, safety and comfort benefits. The project objectives are listed below:

- Objective 1: Define a set of acceptable platooning strategies that will allow road trains to operate on public motorways without changes to the road and roadside infrastructure.
- Objective 2: Develop and integrate technologies for a prototype platooning system to evaluate the defined strategies in real-world scenarios.
- Objective 3: Show how platoons can lead to environmental, safety and congestion improvements.
- Objective 4: Illustrate how a new business model can be used to encourage the use of platoons with benefits to both lead vehicle operators and to platoon subscribers.

From this broad project scope, the actions or deliverables specifically relevant to VECTO are the following:

- Deliverable 2.2. describes the analysis of platooning concepts. A platooning concept is a set of combined use cases and procedures which describe the complete concept of the platoon including how to join, maintain and dissolve platoons.
- WP4 was the phase of the project where all the final testing activities took place. All the sub-systems, developed by each partner, had previously been tested individually and integrated during WP3.
- Project Final Report: Fuel Consumption chapter contains the results obtained from the work done in the Computational Fluid Dynamics (CFD) aerodynamic simulation and the fuel consumption tests at the track. All of these involved the fully functional platoon.

5.1.1.2 COMPANION [83]

The aim of COMPANION project was to develop co-operative mobility technologies for supervised vehicle platooning, to improve fuel efficiency and safety for goods transport. The objectives were as follows:

- Objective 1: Development and Validation of a fault tolerant, scalable off-board decision-making system to determine the optimal coordination of platoons, under current infrastructure state, to improve the energy effectiveness and safety of road transportation systems.
- Objective 2: Development and Validation of a fault tolerant, scalable on-board system for coordinated heavy-duty platooning.
- Objective 3: Development and Validation of multimodal, in-vehicle and coordination centre user interfaces to safely and effectively inform and interact with platooning drivers and transport planners.
- Objective 4: Identification of standardization and legislative gaps and the proposal of legal solutions and new technological standards to advance the large-scale adoption of platooning technologies.
- Objective 5: The demonstration of platooning operations on European roads in multiple countries.

Within the objectives described above, the most relevant ones for VECTO are objectives 4 and 5, since they can provide valuable input information for the development of the present project.

5.1.1.3 ENSEMBLE [84]

The main goal of the ENSEMBLE project was to pave the way for the adoption of multi-brand truck platooning in Europe to improve fuel economy, traffic safety and throughput. This was demonstrated by driving six differently branded trucks in one (or more) platoon(s) under real world traffic conditions across national borders (Figure 97). The specific ENSEMBLE objectives were as follows:

- Objective 1: Achieve safe platooning for trucks of different brands. Relevant authorities will be approached to jointly define road approval requirements including V2I communication.
- Objective 2: Work towards the standardization of different aspects of platooning: manoeuvres for forming and dissolving of platoons, operational conditions, communication protocols, message sets, and safety mechanisms.
- Objective 3: Real-life platooning: The intended practical tests on test tracks and in real life.



Figure 97. Multi-brand truck platoon driving on public road.

5.1.1.4 AEROFLEX [85]

AEROFLEX was a European project whose framework is the area of automated and connected vehicles. The aim of the AEROFLEX project was to develop and demonstrate new technologies, concepts, and architectures for complete vehicles with optimized aerodynamics, powertrains, and safety systems as well as flexible and adaptable loading units with advanced interconnectedness contributing to the vision of a “physical internet”. There were four main objectives, as stated below:

- Objective 1: Characterize the European freight transport market (map, quantify and predict), the drivers, the constraints, the trends, and the mode and vehicle choice criteria.
- Objective 2: Develop new concepts and technologies for trucks with reduced drag, which are safer, comfortable, configurable, and cost effective and ensure satisfaction of intermodal customer needs under varying transport tasks and conditions.
- Objective 3: Demonstrate potential truck aerodynamics and energy management improvements with associated impact assessments of the new vehicle concepts, technologies and features developed in the AEROFLEX project.

- Objective 4: Drafting of coherent recommendations for revising standards and legislative frameworks to allow the new aerodynamic and flexible vehicle concepts on the road.

Conclusions relevant to VECTO can be drawn from the work on objectives 2, 3 and 4.

5.1.1.5 HFAUTO (Human Factors of Automated Driving) [86]

For autonomous driving to play an important role on European roads in the coming years, safety factors need to be considered and developed before implementation: human-machine interfaces (HMI), the evaluation of the driver's condition and the control of traffic flows are aspects to consider.

Some of these factors were addressed in this project. Different scenarios of driving automation were proposed. First, adaptive cruise control (ACC) was considered, where the driver is provided with support in longitudinal control (acceleration and braking). In the next step, an SAE level 2 automation scenario was analysed. This means that the driver receives support in both longitudinal control (acceleration and braking by ACC) and lateral control (steering by automated lane keeping system). Finally, an SAE level 3 automation scenario was analysed. In this scenario, the driver is allowed to take his eyes off the road, since his interaction with the vehicle is only necessary in emergency situations.

To investigate human interaction (HMI) in the automation scenarios described above, not only tests were carried out in driving simulators but also tests on the open road. In addition, these study focused on different types of vehicles, including the circulation of heavy-duty vehicles in platoon mode.

5.1.1.6 ROADART (Research On Alternative Diversity Aspects for Trucks) [87]

The ROADART project was based on the research and application of different communication systems with the aim of ensuring and improving road safety on European roads. During the development of the project, the integration of Intelligent Transportation Systems (ITS) communication systems was investigated, aimed at improving the traffic safety of heavy-duty vehicles in platoon mode. For this, different tests were carried out considering critical situations in realistic traffic environments. Aspects such as the circulation of platoons in tunnels, high traffic densities and so on were successfully tested, not only at a technical level but also in terms of greenhouse gas emissions.

5.1.1.7 CONNECTING AUSTRIA – First Results of C-ITS Focused Level 1 Truck Platooning Deployment [88]

This project assessed the potential of platooning in terms of traffic efficiency. By implementing platooning strategies, it is expected to improve traffic efficiency and to reduce the number of traffic congestions. Platooning improves traffic efficiency by reducing distances between trucks at constant speed. Since more vehicles can pass a traffic lane per hour, the traffic density is increased.

On the other hand, a cooperative system that manages platoons has been evaluated. Three key areas have been identified: sensor, data exchange and infrastructure-based control strategies for use cases in the interurban and urban area. It aims to manage the traffic flow including platoons dynamically.

Finally, traffic safety regarding platoons has been evaluated. There could be some situations in which platooning may lead to extra risks with respect to safety such as overtaking distances, overtaking durations or crossing of platoons. It should be considered that in case of danger zones, a temporally dissolution of the

platoon (partial or global) would benefit traffic safety. On this topic, environmental issues could be affected negatively since fuel consumption would increase. Anyway, from a social point of view, traffic safety is increased under this situation.

5.1.1.8 EDDI - Electronic Drawbar - Digital Innovation [89]

The EDDI (Elektronische Deichsel - Digitale Innovation) project ran from mid-2017 to mid-2019 and was funded by the German Federal Ministry of Digital Affairs and Transport. As part of the EDDI project, digitally networked truck convoys were developed and tested in real road and logistics traffic over an extended period of time. The practical suitability and system security of this so-called platooning technology were the focus of the world's first practical test for the logistics company DB Schenker and the manufacturer MAN Truck & Bus. On the BAB 9 motorway between Munich and Nuremberg, everyday road freight transport was carried out in platoons with a vehicle distance of between 15 and 21 metres over a period of three months in order to gain insights for regular use. The effects on the professional drivers were investigated by the scientific partner, Fresenius University of Applied Sciences, both psychosocially in open interviews and neurophysiologically with mobile EEG and eye-tracking measurements.

5.1.1.9 HELM UK [90]

HelmUK was the first UK trial of a truck platooning technology, specifically the Cooperative Adaptive Cruise Control (CACC) system, which ran between 2017 and 2022. The project analysed operational aspects, safety and potential fuel savings. The project also made recommendations for the development and deployment of platooning for the National Highways the UK government and the freight industry.

5.1.2 Regulations and discussion groups

Many advancements are being made at the heavy-duty vehicles' industry. From electrification of vehicles to the progress being made with autonomous and automated technologies, all these breakthroughs are being developed with the aim of, among others, increasing vehicle safety, improving performance, and reducing emissions.

With all these innovations coming at a fast pace, the regulatory bodies are working continuously to adapt all the regulations to include all current and forthcoming technologies. This section aims at summarizing the work that is being developed within the discussion groups at a United Nations and European level.

5.1.2.1 UNECE (WP.29)

The UNECE World Forum for Harmonization of Vehicle Regulations (WP.29) [91] is the worldwide regulatory forum within the institutional framework of the UNECE Inland Transport Committee (ITC). Its Contracting parties (member countries) can attend the WP.29 triannual sessions where they discuss and establish the regulatory instruments concerning motor vehicles and motor vehicle equipment.

As it is stated in its own description: Overall, the regulatory framework developed by the World Forum WP.29 allows the market introduction of innovative vehicle technologies, while continuously improving global vehicle safety. The framework enables decreasing environmental pollution and energy consumption, as well as the improvement of anti-theft capabilities. [91]

To deal with the different topics regarding motor vehicles, WP.29 established six permanent Working Parties (GRs) - subsidiary bodies - that consider specialized tasks, consisting of people with a specific expertise. This subsidiary bodies were rearranged in 2018 to include these new technologies that are arising quickly, so currently the working groups are:

- Noise and Tyres (GRBP)
- Lighting and Light-Signalling (GRE)
- Pollution and Energy (GRPE)
- Automated and Connected Vehicles (GRVA)
- General Safety Provisions (GRSG)
- Passive Safety (GRSP).

Additionally, WP.29 also establishes different Informal Working Groups (IWGs) that are aimed at dealing with certain technical issues during a limited time mandate and which report either to the WP.29 directly or to one of the GRs.

The GRVA is the Working Party dedicated to the activities related to automated, autonomous, and connected vehicles. There are eight different Informal Working Groups reporting nowadays to the GRVA that deal with the following topics

- Functional Requirements for Automated and Autonomous Vehicles (FRAV)
- Validation Method for Automated Driving (VMAD)
- Cyber Security and (OTA) software updates (CS/OTA)
- Data Storage System for Automated Vehicle and Event Data Recorder (DSSAD/EDR)
- Automatically Commanded Steering Function (ACSF)
- Automatic Emergency Braking and Lane Departure Warning Systems (AEBS/LDWS)
- Modular Vehicle Combinations (MVC)

These informal groups of GRVA work with the purpose of developing the new regulations and cover systems that are not already legislated.

5.1.2.2 Functional Requirements for Automated and Autonomous Vehicles (FRAV)

This IWG was created in 2019 with the aim of developing functional (performance) and safety requirements for automated and autonomous vehicles. It would focus on the combination of the different functions for driving: longitudinal control (acceleration, braking and road speed), lateral control (lane discipline), environment monitoring (headway, side, rear), minimum risk manoeuvre, transition demand, Human Machine Interface (HMI, internal and external) and driver monitoring.

5.1.2.3 New Validation Method for Automated Driving (VMAD)

With the rapid evolution of new technologies performing driving tasks, some countries started developing guidelines for the introduction of automated driving systems including future-proof validation methods. The VMAD IWG was created to create appropriate and harmonized methods to assess the driving performance of automated driving systems. To achieve this, a clear objective was set; to assess the safety of driving

performance of automated driving systems including safe responses to the environment as well as safe behaviour towards other road users.

5.1.2.4 Cybersecurity & Software Updates

This IWG was initially created as a Task Force that was a subgroup of the Informal Working Group on Intelligent Transport Systems / Automated Driving (IWG on ITS/AD) of WP.29. Its main goal is to address Cyber Security and data protection issues and software updates relevant for the automotive industry. To this end, the IWG is developing relevant recommendations, provisions and documentation regarding the topics mentioned.

5.1.2.5 Automatically Commanded Steering Functions (ACSF)

The ACSF informal group was created to review the requirements and limitations associated with Automatically Commanded Steering Function technology (ACSF) as defined in Regulation No. 79. Its main goal has been to prepare a draft regulatory proposal regarding advances in control system technology. Upon its creation, the informal group was meant to address the following issues:

- Review the speed limitation (10 km/h) with the purpose of permitting ACSF functionality during [urban] and [interurban] journeys.
- Define requirements for communicating to the driver a malfunction of ACSF.
- Define requirements to enable the evaluation of ACSF during periodic technical inspection.

5.1.2.6 General Safety Regulation (EC)

In December 2019, a new version of the General Safety Regulation (GRS) was published in the Official Journal of the European Union. According to clause 25, one of the functions that shall be regulated on the upcoming years is platooning:

“(25) Vehicle platooning has the potential to bring about safer, cleaner and more efficient transport in the future. In anticipation of the introduction of platooning technology and the relevant standards, a regulatory framework with harmonized rules and procedures will be needed.”

The connectivity and automation of vehicles increase the possibility for unauthorized remote access to in-vehicle data and the illegal modification of software over the air. In order to take into account such risks, UN Regulations or other regulatory acts on cyber security should be applied on a mandatory basis as soon as possible after their entry into force.

Some of the specific requirements relating to automated vehicles and fully automated vehicles are:

- Systems to replace the driver’s control of the vehicle, including signalling, steering, accelerating, and braking (implemented by Regulation (EU) 2022/1426).
- Systems to provide the vehicle with real-time information on the state of the vehicle and the surrounding area (implemented by Regulation (EU) 2022/1426).
- Driver availability monitoring systems (implemented by Regulation (EU) 2022/1426).
- Event data recorders for automated vehicles (implemented by Regulation (EU) 2022/1426).
- Harmonized format for the exchange of data for instance for multi-brand vehicle platooning (no implementing act published yet).

- Systems to provide safety information to other road users (implemented by Regulation (EU) 2022/1426).

As can be seen from the above list, the provisions specific to platooning have not yet been included in any implementing act.

5.1.3 Vehicle technology descriptions

The following section describes the vehicle technologies that have been identified as potentially relevant in the context of Task 4.

5.1.3.1 Adaptive Cruise Control (ACC)

Adaptive Cruise Control (ACC) is a semi-automated driving function that has already a significant market share in recent years. ACC allows the driver to set a fixed, time-based distance to the vehicle, and then automatically maintains this distance. Thus in a certain way, this system can be considered a pre-stage of platooning technology. However, the driver is still fully responsible for driving the vehicle and represents the necessary fall-back in case the system fails.

For driving with ACC, the same minimum distances to the vehicle in front (50 metres for vehicle speeds greater than 50 km/h) apply as for conventional vehicles. Thus, no fuel consumption advantages can be expected from ACC for the slipstream effect characteristic of platooning.

Furthermore, the use of ACC overlaps with the fuel-saving effects of PCC. For the latter, vehicles need to drive vehicle and payload specific speed profiles in hilly road sections. This is not possible when using ACC.²⁶

With regard to ACC, it is assessed that this technology is not a feature of the vehicle that should be assigned a savings effect in VECTO.

5.1.3.2 Platooning

Basic mode of operation

Operation of vehicles in platoon mode is made up of three types of vehicles: 1 Leader Vehicle (LV), 1 or more Following Vehicles in an intermediate position (FV1) and 1 Following Vehicle that closes the convoy (FV2).

The basic mode of operation takes place as follows: several heavy-duty vehicles drive in a consecutive basis virtually connected. They are commanded under the instructions of the Leader Vehicle (LV) in terms of acceleration, deceleration, direction and so on. Depending on the gap between the heavy-duty vehicles involved in the platoon (LV, FV1 and FV2), an aerodynamic gain will be obtained mainly in the FV1 and FV2 vehicles, thus reducing fuel consumption and CO₂ emissions of the convoy.

As previously mentioned, the basic mode of operation of the circulation of heavy-duty vehicles in platoon mode is based on the connectivity and exchange of information between vehicles. From the point of view of operations, SARTRE project identified the 4 basic functions that shall be considered and developed to guarantee the correct functioning of platooning which are:

²⁶ As also mentioned below, the effect of PCC in such driving conditions - i.e. at higher traffic densities - is limited anyway. This limitation is currently not taken into account in VECTO.

- Creating
- Joining
- Maintaining, and
- Dissolving of platoons.

During ENSEMBLE project, several manoeuvres have been performed in a test track such as joining the platoon, dividing the platoon, reducing, and increasing speed, emergency braking or increasing the gap between vehicles.

On the other hand, as previously stated, the aerodynamic gain of the following vehicles (FV1 and FV2) depends fundamentally on the gap between vehicles. In accordance with previous European projects, this aspect can be approached in two ways. On the one hand, there is the *Distance-based Gap*. This concept was the one used in the COMPANION project. The *Distance-based Gap* consists of maintaining a constant distance between vehicles in any condition. The main advantage is that it is possible to maintain a relatively constant aerodynamic reduction. However, depending on the vehicle speed, the distance may not be sufficient in terms of traffic safety. In the case of COMPANION, the tests were carried out at a fixed distance of 10, 12, 15 and 20 meters at two different speeds (70 and 80 km/h). On the other hand, there is the *Time-based Gap*. This concept was the one used in EMSEMBLE project. The *Time-based Gap* consists of maintaining a constant time between vehicles in any condition. In this case, depending on the speed of circulation, the distance between vehicles will be greater or less. This concept resembles the operation of adaptive cruise control (ACC). This configuration has the main advantage of ensuring traffic safety. However, from an energetic point of view, the aerodynamic improvement is reduced from *Distance-base Gap* configuration, as speed increases due to a greater distance between vehicles. In the case of EMSEMBLE, the tests were carried out taking a constant time between vehicles of 1.4 seconds.

Technical requirements

The circulation of heavy-duty vehicles in platoon mode requires the development of communication systems between vehicles. It is essential to develop appropriate systems that allow the exchange of information between the different units that make up the platoon to allow the different operations: creating, joining, maintaining, and dissolving platoons.

In that sense, a system capable of managing the different operations that can take place when circulating in platoon mode must be considered. In the COMPANION project, a qualitative layered platoon control system to plan and control the hierarchy of the platoon was proposed. It is based on 3 different level layers. First level is related to the *Tactical Layer*. This level contents the strategic plan by optimizing the road segment and orchestrating the platoon, by considering the vehicles that are going to take part in the platoon. The following level is the *Operational Layer* that controls the platoon operative and the vehicles by considering several factors such as environmental models, vehicle properties, speed control and so on. Finally, the *Human-Machine Interface Layer* is essential to keep drivers in the loop by increasing the awareness situation and assisting them with platooning operations.

To implement the above information exchange and management system, it is necessary to develop an adequate communication system between vehicles. In this regard, great progress has been made within the framework of the ENSEMBLE project. In this project, based on Europe-wide deployment of platooning, multi-brand truck platooning solutions were tested both on open road and close road. During the development of the project, the mainly target was focused on working on the most appropriate communication protocol to facilitate the exchange of information between vehicles effectively. The solution proposed by the different brands that participated in the project is based on the V2V communication protocol. Several manoeuvres have been

performed in a test track by using this communication protocol. The manoeuvres results using this system were assessed by using Key Performance Indicators (KPI) with satisfactory results.

On the other hand, the protection and security of these new information exchange systems must be considered. Data protection requirements must be established and fulfilled to guarantee the cybersecurity of those systems. This means that platooning and automated systems framework must be considered from a regulatory point of view by considering its cybersecurity. In this way there are different working groups that shall consider these new systems to perform new regulation requirements. On the one hand, there is the GRVA. This is the Working Party dedicated to the activities related to automated, autonomous, and connected vehicles. These informal groups of GRVA work with the purpose of developing the new regulations and cover systems that are not already legislated. On the other hand, there is the FRAV. This is Functional Requirements for Automated and Autonomous Vehicles. It aims to develop functional and safety requirements related for automated vehicles focusing on the different functions for driving such as longitudinal and lateral control, environmental and driver monitoring and so on. From a regulatory point of view, these requirements will impact road users whose safety will be guaranteed. Finally, the VMAD (New Validation Method for Automated Driving) aims to create appropriate and harmonized methods to assess the driving performance of automated driving systems by assessing the safety of driving performance of automated driving systems. All these working groups will play a fundamental role in the coming years. The main objective will be to develop adequate regulatory frameworks that establish the necessary technical requirements to ensure the cybersecurity of the different communication systems aimed at autonomous driving, such as platooning, and its related communication system based on V2V communication protocol.

General requirements on the infrastructure

In previous sections, the technical requirements necessary at the vehicle level for the implementation of platooning on European roads have been raised. However, in addition to the requirements at the vehicle level, it is essential to establish improvements and adaptations in the infrastructure to future autonomous driving interact with new communications technologies such as platooning.

Next generation of roads will require high levels of adaptation, automation, and resilience. On the one hand, adaptable road should be focused on ways to allow road operators to respond in a flexible manner to changes in road users demands and constraints. On the other hand, automated road should be focused on the full integration of intelligent communication technology applications between the user, the vehicle, traffic management services and the road operations. At the end, resilient road should be focused on ensuring that service levels are maintained not only under extreme weather conditions but also under extreme traffic conditions.

The circulation of heavy-duty vehicles in platoon mode should be considered as a first step to reach autonomous driving in European roads. Regarding platooning introduction in the infrastructure, two relevant layers should be developed to allow these configurations in the roads. On the one hand, it is the *service layer*. It shall describe for which roads platooning is allowed and which restrictions are relevant. On the other hand, it is the *strategic layer*. This layer shall provide platoon match candidates based on logistical or operational data based on matching concepts. In this sense, in recent years work has been carried out within the framework of European projects on different concepts of infrastructure improvement. One of the most relevant is the Intelligent Access Policy (IAP). IAP aims to ensure equitable access of vehicles to the infrastructure by digitalization. The emphasis is to establish a form of a road traffic management system that connects HDV with infrastructure from truck drivers, other road users and traffic point of view. The system aims to regulate access to specific urban areas and locations, categorized into several access levels. Thus, it will improve the efficiency in the transport process. Vehicle operators may gain by using new vehicles, new technologies, and optimized routing. This optimization of the transport process will reduce the associated costs. Besides of that,

an optimized routing will reduce the fuel consumption and CO₂ emissions of freight vehicles. On the other hand, regarding the infrastructure monitoring, by using IAP road authorities could continuously monitor the loading state of vehicles and enforce the infrastructure is not overloaded by road freight vehicles. This is a relevant point, since overloaded infrastructures have negative impacts not only on society, but also on economy (stress, accidents, infrastructure reparations...)

At the end, IAP aims to get a better usage of infrastructure. This will benefit by reduced emissions from the road freight by reducing the congestions, which is beneficial in multiple dimensions. Road traffic congestions are a serious inconvenience in European cities. They have a direct impact on fuel consumption and CO₂ emissions. By reducing these congestions, not only this issue could be improved, but also the waste of time of road users.

Platoon strategies

In this section, the different strategies that exist for the implementation of platooning on European roads are presented. Basically, the strategies are classified according to the degree of driving automation. According to the European project ENSEMBLE, there are two fundamental strategies: *Platooning Support Function* and *Platooning Automated Function*. In Table 33, the main differences between both strategies are presented:

Table 33: Platooning strategies

Platooning Support Function (PSF)	Platooning Automated Function (PAF)
SAE L1 Automation Level	SAE L4 Automation Level
Only the longitudinal control (acceleration, deceleration) is automated for the following vehicles (FV1 and FV2)	Both longitudinal and lateral control of the following vehicles (FV1 and FV2) are automated
Drivers must be present in all the vehicles (LV, FV1 and FV2)	Driver is mandatory in the leader vehicle (LV). Drivers in the following vehicles (FV1 and FV2) are not necessary
Drivers in the following trucks are responsible for DDT (Dynamic Driving Task) and they are the fallback	The autonomous system is responsible for DDT (Dynamic Driving Task) and the system is the fallback
Gap: Basically a minimum of 1.4s must be maintained between the vehicles. Some systems, like CACC, work also with smaller gaps (0.8 to 1.2s under certain boundary conditions for payload and road conditions) .	Time-based Gap: Gap may be much lower than 1.4s (down to min. 10m)

As can be seen in Table 1, the *Platooning Support Function* strategy has several limitations with respect to the *Platooning Automated Function* strategy. Since only longitudinal controls are automated and driving responsibility lies with the driver, the gap between vehicles needs to be greater for safety reasons. This means less gain in aerodynamic terms and, therefore, in fuel consumption and CO₂ emissions. However, as the ENSEMBLE project has shown, this strategy is currently highly developed at vehicle level. This will allow it to be considered as a real option to be implemented in the short term. Future efforts might also focus on the

development of the *Platooning Automated Function* strategy, with the aim of achieving a greater reduction in fuel consumption and CO₂ emissions terms. For this, it will not only be enough to develop and improve automated systems at the vehicle level, but efforts must be concentrated on improving infrastructures as explained in previous section.

General limitations of platooning

This section examines the main general limitations of platooning and the various improvements that need to be made in the future.

On the one hand, it must be considered that the technology, both at the vehicle level and at the infrastructure level, only allows heavy-duty vehicles to circulate in platoon mode under certain traffic conditions. Specifically, platooning is a feasible technology if traffic takes place on highways and motorways, that is, high-capacity roads. Its implementation on urban, interurban, or secondary roads is not contemplated since traffic conditions make this technology unfeasible. Nevertheless, this issue is not a great disadvantage, since the aerodynamic improvement when driving at low speeds is minimal.

A certain limitation of platooning also arises from weather conditions. In environmental conditions with poor road grip (rain, snow), the vehicle distance must be increased for safety reasons.

Furthermore, as explained in previous sections, the circulation of heavy-duty vehicles in platoon mode is based on connectivity and the exchange of information between vehicles. Part of the communication system bases its operating principle on GPS signals. This has a great advantage from the point of view of the accuracy of the communication system. However, it can be a problem in certain driving conditions, such as driving in tunnels since a loss of GPS signal from one or more vehicles can cause the peloton to break up. During the public demonstration of the European project ENSEMBLE, this aspect was marked as a point for improvement in the future.

Another point of improvement identified in the ENSEMBLE project that could cause the platoon to break up is the slope of the road. On certain occasions where the slope of the road is too high, the difference in power between the vehicles that make up the platoon can cause some imbalance in the operation of the platoon. For example, if the lead vehicle has greater power than its followers, the situation could arise that on a steep slope the following vehicles would have difficulty maintaining the established gap, potentially causing a disengagement from the peloton. Or, conversely, if the lead vehicle is less powerful than the following vehicles, the situation could arise where these vehicles are forced to drive with significantly lower speeds, which could lead to the driver's intention to leave the platoon for driving time reasons. If such effects result in significantly lower average speeds in the case of driving in a platoon (and the ENSEMBLE results indicate this, see task 4.2), this could also be a potentially critical aspect for fleet operators due to the extended trip times.

Another limitation of platooning is that the effect of the ADAS function predictive cruise control (PCC) is largely lost due to the aforementioned combination of vehicles with different masses and driving resistances. In order to make optimal use of PCC, vehicles would have to drive with individual, mass-dependent speed profiles when driving over crests or through dips. This is impossible with the simultaneous use of platooning.²⁷

Although the limitations listed above represent important points for either improvement of technology or especially limitations in the general applicability and/or acceptance, they are currently not seen a principle threat to the implementation of platooning on European roads. However, the general restrictions in applicability are very much a significant factor that must be taken into account in a potential implementation in Regulation

²⁷ The effect of PCC is also limited in trips with high traffic densities. This is currently neglected in VECTO. PCC has a reduction effect of approx. 2% in the updated long haul cycle.

(EU) 2017/2400, as the savings potentials assigned there are intended to reflect the conditions in real operations. This is discussed in more detail in subtasks 4.3 and 4.4.

5.2 Subtask 4.2: Environmental, economic, and social impacts

This subtask describes the environmental, economic, and social impacts of platooning. The description in this subtask concentrates on summarising the published results from the cited projects. The derivation of potential effects for typical use in road traffic as they could be depicted in VECTO is described in section 4.4.

5.2.1 Environmental

From an environmental point of view, platooning has potential in terms of reducing greenhouse gas emissions. Minimizing the distance between vehicles reduces the aerodynamic drag, thereby also reducing fuel consumption and CO₂ emissions. As described below, there may also be other related impacts that have an effect on CO₂ and fuel consumption, especially changes in driving speed profiles.

5.2.1.1 COMPANION

The tests carried out in COMPANION were based on the *Distance-Based GAP* strategy. The tests took place in a closed road where 3 heavy-duty vehicles circulated in platoon mode as follows: a leader vehicle (LV), a following vehicle 1 (FV1) - representative of any vehicle circulating in a platoon in intermediate position - and a following vehicle 2 (FV2) - representative of any vehicle closing a platoon. In this configuration, constant speed tests were carried out at 70 and 80 km/h at different gaps between vehicles: 20, 15, 12 and 10 m. The 10m gap was only carried out at 70 km/h for safety reasons. Additionally, tests were also carried out at the same speeds in *solo* configuration with the aim of characterizing the FV1 and FV2 vehicles in terms of fuel consumption. Regarding the type of vehicle, tractor articulated trucks with a standard closed box semi-trailer were used. All tests were carried out empty with the aim of minimizing the impact of mass in terms of fuel consumption. The approximate mass of each vehicle was 16.600kg.

Table 34 and Table 35 show the fuel consumption results obtained in these tests for both vehicles (FV1 and FV2). It should be noticed that the tests took place on a circular track. Fuel consumption measurements were made on the north and south straights. At this point, it should be considered that the northern road had a negative slope of 0.3%, while the slope of the southern road had the same value but was positive. Therefore, for the results to be representative, the arithmetic mean of both measured fuel consumptions will be considered.

From an environmental point of view, the fuel consumption results obtained in these tests confirm the approximations made in other projects using fluid dynamic simulation (as presented in point 5.2.1.4 related to SARTRE project results). Fuel consumption is minimized as the gap is reduced due to lower air drag force. In this way, the maximum fuel consumption is obtained when the vehicle circulates in *solo* configuration at maximum speed (80 km/h), while the minimum fuel consumption is obtained at the minimum gap (10 m) at 70 km/h. It is important to note that the vehicle that circulates in the intermediate position (FV1) is the one that has the greatest aerodynamic benefit, while the vehicle that closes the platoon (FV2) obtains a smaller reduction in terms of fuel consumption. This phenomenon can be explained by the fact that the vehicle in the middle benefits from both the suction of the vehicle in front and the overpressure field of the vehicle behind.

For the last vehicle in the platoon only the suction effect applies, for the first vehicle in the platoon only the overpressure effect (which has a much smaller impact than the suction).²⁸

The improvement in terms of energy consumption as measured under these ideal conditions is notable, managing to reduce energy consumption by approximately 5% to 10% when vehicles circulate in platoon mode.

Table 34: Fuel consumption test track results for Following Vehicle 1 in COMPANION project [92]

FV1							
13/08/2015							
FC North road	Speed North	FC South road	Speed South	Average FC	Average Speed	Gap	Reduction
l/100km	km/h	l/100km	km/h	l/100km	km/h	m	%
15,42	70,20	22,89	70,10	19,26	70,15	Solo	
14,21	70,59	21,12	70,52	17,67	70,55	20	8,3%
13,85	70,59	20,79	70,52	17,32	70,56	15	10,1%
13,58	69,94	20,08	69,90	16,83	69,92	12	12,6%
13,30	70,00	20,65	69,86	16,97	69,93	10	11,9%

14/08/2015							
FC North road	Speed North	FC South road	Speed South	Average FC	Average Speed	Gap	Reduction
l/100km	km/h	l/100km	km/h	l/100km	km/h	m	%
18,08	79,80	23,92	79,68	21,00	79,74	Solo	
15,70	80,60	22,52	80,40	19,11	80,50	20	9,0%
14,71	80,04	23,41	79,90	19,06	79,97	15	9,2%
14,37	80,04	23,49	79,90	18,93	79,97	12	9,9%

Table 35: Fuel consumption test track results for Following Vehicle 2 in COMPANION project [92]

FV2							
13/08/2015							
FC North road	Speed North	FC South road	Speed South	Average FC	Average Speed	Gap	Reduction
l/100km	km/h	l/100km	km/h	l/100km	km/h	m	%
14,13	69,89	21,27	70,01	17,70	69,95	Solo	
13,03	70,60	19,97	70,52	16,50	70,56	20	6,8%
13,20	70,61	20,06	70,56	16,63	70,58	15	6,1%
14,20	70,00	20,10	69,90	17,15	69,95	12	3,1%
12,91	70,77	20,11	70,61	16,51	70,69	10	6,7%

14/08/2015							
FC North road	Speed North	FC South road	Speed South	Average FC	Average Speed	Gap	Reduction
l/100km	km/h	l/100km	km/h	l/100km	km/h	m	%
16,89	79,20	22,87	79,01	19,88	79,11	Solo	
15,14	80,60	21,74	80,40	18,44	80,50	20	7,2%
15,60	80,04	22,64	79,90	19,12	79,97	15	3,8%
14,32	79,98	23,43	80,00	18,87	79,99	12	5,0%

5.2.1.2 ENSEMBLE

The European project ENSEMBLE developed and tested the circulation of heavy-duty vehicles in multi-brand platoon mode. The main objective of this project from an environmental point of view was to identify and understand the dependencies in terms of fuel consumption and pollutant emissions of multi-brand platooning.

²⁸ The consumption saving effect on the leader vehicle (LV) was determined as not significant in COMPANION.

In this project, two types of tests were carried out: on the one hand in a circuit under controlled conditions and on the other hand on an open road. To be able to make a comparison, as in COMPANION, fuel consumption measurements were made of the vehicles involved in solo configuration and in platooning configuration. For the case of circulation in platoon mode, the *Time-Based Gap* method was used. The gap that was established to perform the tests was 1.4s. As explained in the project documentation, this figure is justified from the time to collision (TTC). According to several studies, the TTC is established in approximately 4.4 seconds. During this period, the driver's reaction time (approximately 3 seconds) is considered, including the time that elapses from the perception of the stimuli by the human brain until the decision is made. Therefore, for security reasons, a minimum gap of 1.4 seconds was established, which is considered as the needed time to avoid a collision. This time is approximately 30 m at a constant driving speed of 80 km/h. It should be considered that the currently developed multi-brand platoon mode is the *Platooning Support Function*. This implies that driving is not completely autonomous, so the driver must be always alert and is responsible for controlling the vehicle longitudinally and laterally in the event of a system failure. In the future, with the development and implementation of the *Platooning Automated Function*, it is expected that the gap between vehicles can be reduced below 1 second, since driver intervention will not be necessary and, therefore, it will not be necessary to consider human reaction times.

The circuit tests under controlled conditions took place in the same circuit in which the COMPANION tests were carried out. The conclusions in terms of fuel consumption using the *Platooning Support Function* at 1.4 seconds between vehicles are very similar to those obtained for the COMPANION project. It is concluded that for the leader vehicle (LV) there is no significant improvement in terms of fuel consumption. However, for vehicles in intermediate position (FV1), a reduction in fuel consumption of approximately 7% is obtained. These results are in line with those obtained in previous projects. The reduction in fuel consumption is lower than that obtained in COMPANION (10%), but it should be considered that the gap between vehicles in this project is slightly higher.

On the other hand, the open road tests took place in the northeast of Spain. A highway route was selected to test the circulation of multi-brand vehicles in platoon mode. The selected route was approximately 100 km of distance. The accumulated slope of the route was 500 m, with a maximum altitude difference of 100 m. Also, the tests were performed in solo configuration and in platooning configuration, just to compare the final fuel consumption results. Like the track tests, the platooning tests were performed using the *Platooning Support Function* at a gap between vehicles of 1.4s.

Figure 98 shows the average fuel consumption result obtained for vehicles in solo configuration and in platoon configuration (average of positions within the platoon, i.e. vehicles in the middle and at the end) for the ENSEMBLE open road tests. Like the results obtained in the track tests, lower fuel consumption and CO₂ emissions are obtained for vehicles that circulate in platoon mode. However, as will be explained below, for the open road tests this reduction in fuel consumption cannot be attributed only to the slip-stream effects.

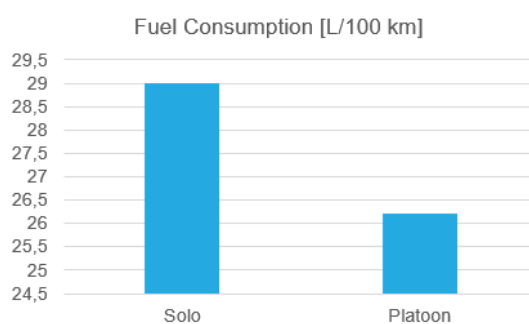

Figure 98: Fuel consumption open road test results in ENSEMBLE project [93]

Figure 99 shows the vehicle speed distributions of six vehicles over a selected motorway part of an open road trip for the case where vehicles were ordered to drive solo and for the case where vehicles were ordered to drive in a platoon. For the platooning case the driving happened at a lower average speed and with more speed variations. The average speed difference between both configurations is approximately 10 km/h. This speed difference has a direct impact on fuel consumption. For this reason, it cannot be concluded that the reduction in fuel consumption of vehicles circulating in platoon configuration is only attributable to the slipstream effect, since the effect of speed fluctuations is significantly. According to the internal analyses of the ENSEMBLE project, this speed fluctuations are mainly associated with changes in the slope of the road. Since the platoon is made up of multi-brand vehicles, with each vehicle having different rated engine power and thus a different power to mass ratio (PMR).²⁹ This implies that when the road slope varies, the vehicles have different capacities to maintain a constant speed, which concludes in variations in the speed of the platoon to maintain the established gap of 1.4 seconds. In conclusion, the multi-brand platoon reaches stability when the speed is uniform but becomes unstable when the speed varies between the vehicles. In this case, this speed variation is directly attributable to variations in the slope of the road due to the PMR effect.

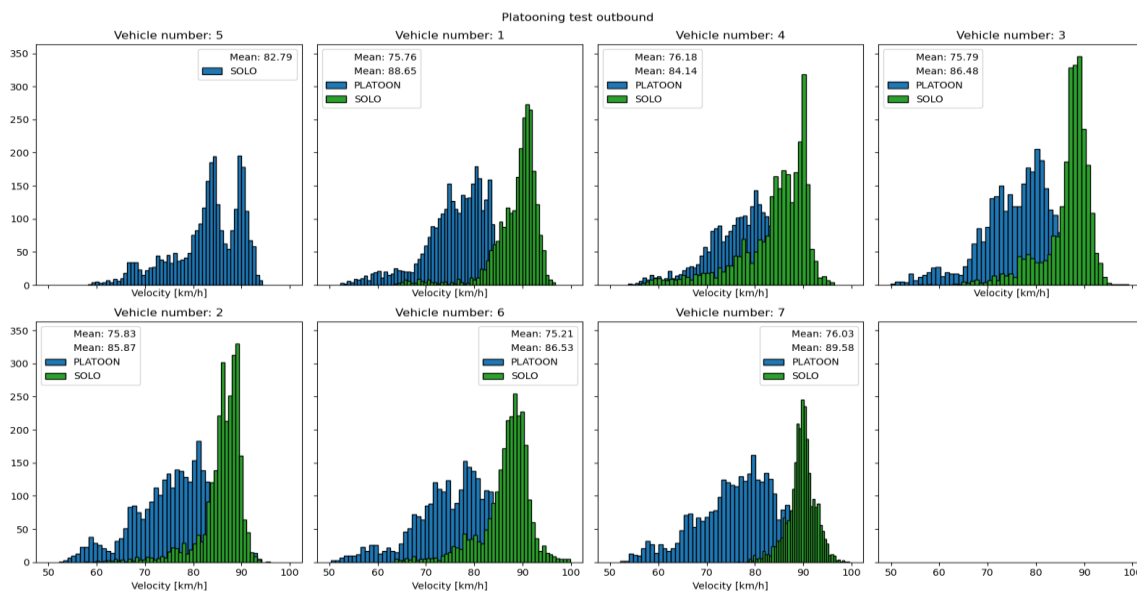

Figure 99: Speed variance comparison between solo and platoon configuration in ENSEMBLE project [93]

The differences in speed distributions between solo and platoon in the ENSEMBLE measurements shown above are so significant that they alone are sufficient to explain the approximate fuel saving effect.³⁰ For the evaluation of platooning, this raises the question, which is much more difficult to answer than for slipstream impacts, of how much platooning changes the driving speed profiles in reality compared to solo operation and what other implications this has (e.g. acceptance by drivers and fleet operators).

²⁹ The payload of the test vehicles was identical at about 19 tonnes.

³⁰ For an average Group 5 vehicle, the fuel saving at 75 km/h cruising speed instead of 85 km/h is about 8 percent.

5.2.1.3 EDDI

In the EDDI project, savings in fuel consumption through platooning in the range of 3 to 4 percent (following vehicles) and 1.5 percent in the lead vehicle were determined. The tests took place in real driving operation on the motorway between Munich and Nuremberg. For this test series, special permission were granted by the authorities. The platooning operation mode was at automation level 2, with a distance between the vehicles of 15 metres (23 metres in wet conditions) and a fixed set speed of 80 km/h. The reference vehicle in solo mode was equipped with PCC (a system that cannot be used in platoon mode, as described above).

Around 50% of the route could be travelled in platooning mode. The reasons that platooning was not allowed are e.g. 500 m before slip roads and exits from motorway intersections, at construction sites, steep inclines / declines, at accident sites or in traffic jams. Also in weather conditions with very poor grip conditions, platooning could not be used.

5.2.1.4 HELM UK

In the HELM UK project, the performance of the platooning technology “Cooperative Adaptive Cruise Control” (CACC) was compared with that of conventional vehicles with ACC. CACC is a function on SAE level 1 (PSF) but using additional control functions³¹ which allows the PSF typical safety distance of 1.4s to be reduced to 0.8s to 1.2s under certain conditions (payload, road, weather). A visual representation of the road trials and vehicle operation is shown in Figure 100. When interpreting the results, it should be noted that the platoon was organised in such a way that only lightly loaded or completely unloaded vehicles were positioned at the rear.

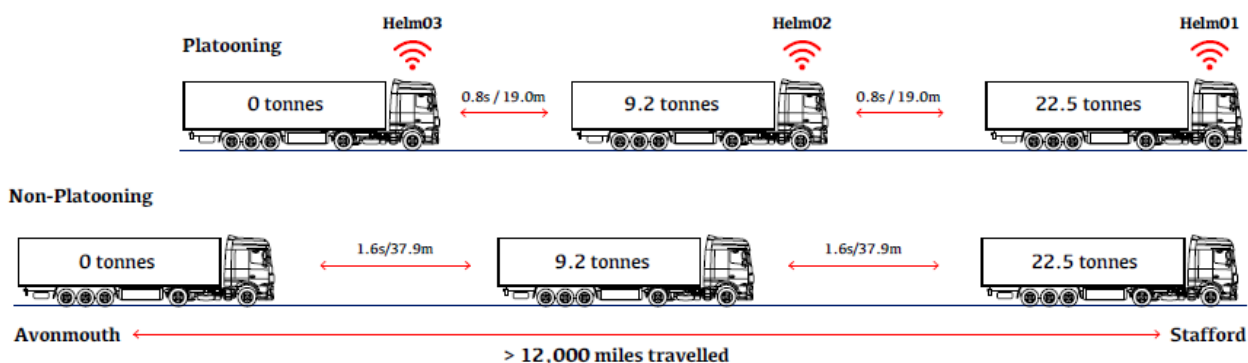

Figure 100: HelmUK trial formation, payloads and vehicle spacing for platooning and non-platooning operation.

Real-world fuel savings

HelmUK found that the measured fuel savings across three vehicles were 0.5% in the HelmUK trial. Statistical modelling showed no evidence that fuel consumption was significantly different to trucks using ACC. Analysis confirmed that the number of junctions which could not be safely platooned through was the main reason for the low fuel savings. The vehicles could spend only 53.5% of their driving time in a platoon.

³¹ Like the “Brake Performance Estimator” which adjusts the distance between the vehicles based on vehicle weight to ensure safety no matter the load or order of the trucks) and the “Cooperative Collision Avoidance” which ensures coordinated automatic emergency braking.

Optimised fuel savings

To further explore the potential of platooning, two optimised scenarios were created from the HelmUK data to represent possible future scenarios for platooning deployment. The first looked at a route where all junctions were suitable for platooning, and the second looked at areas of the route where a high degree of platooning occurred. The measured fuel savings across three vehicles for these two scenarios rose to 1.7% (at 74.7% of time in platoon) and 1.8% (at 85.7% of time in platoon), respectively. Further statistical modelling performed on these two scenarios, which accounted for other variables on fuel consumption (such as traffic flow, journey direction, platooning states, weather, etc.), showed that the fuel savings of platooning alone were marginally greater than the fuel savings directly measured at 2.5% and 2.6%, respectively.

Perfect fuel savings

Finally, it was investigated what platooning could achieve in perfect conditions, where there was completely uninterrupted platooning. In this scenario, fuel measurements from HelmUK showed that platooning could produce fuel savings of 4.1% across three vehicles.

5.2.1.5 SARTRE

The SARTRE project aimed to develop strategies and technologies to allow vehicle platoons to operate on public roads with significant environmental benefits. In this project, tests were carried out by fluid dynamic simulation (CFD) of the circulation of vehicles in platoon mode. It should be noted that in this project, not only platoons exclusively of HDV were considered, but the tests were carried out in a mixed way. That means, a configuration of 2 HDV and 3 LDV closing the platoon was tested as shown in Figure 101.



Figure 101: Platoon configuration used for CFD tests in SARTRE project [94]

In these virtual tests, different gaps between vehicles were simulated: 3, 4, 6, 8, 10 and 15 meters. Figure 102 shows the drag reduction obtained for each vehicle as a function of gap. In general, the results show that for distances less than 4m there is too much instability in aerodynamic terms. The most stable solutions are obtained from 6m between vehicles, where the reduction of aerodynamic resistance begins to be relevant. CFD simulations have shown that driving in platoon mode makes it possible to reduce the resistance of each vehicle, even for the leading vehicle. The following HDV may have drag benefits of around 40%-50%, and for the rest of the following LDV, the air drag (C_x) reductions go up to 60%-75% (Figure 102).

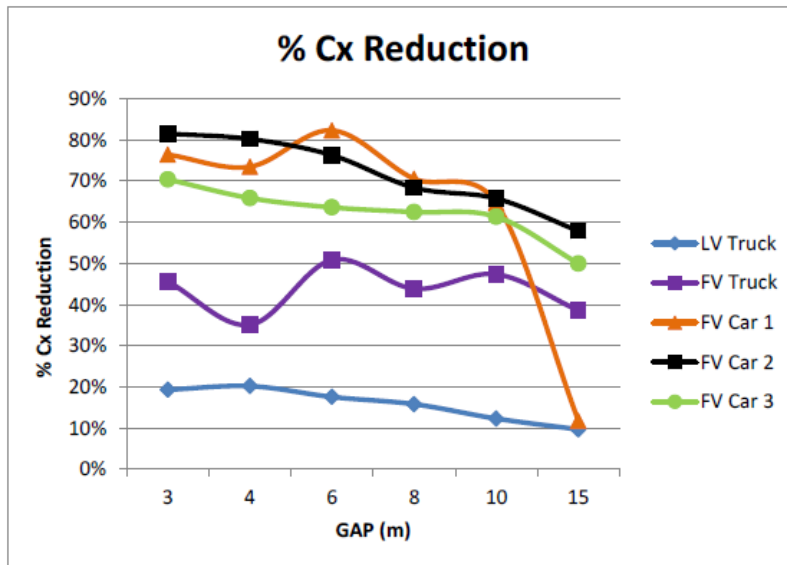

Figure 102: Cx Reduction from CFD simulations in SARTRE project [94]

Note that these results imply the assumption that all vehicles are perfectly aligned in the x-direction. However, in real traffic conditions there is no perfect lateral alignment between vehicles. As was shown in later projects in which real road tests were carried out (COMPANION and ENSEMBLE), the real reduction in aerodynamic drag and fuel consumption terms is lower than the reductions obtained by CFD simulations. The path to improving circulation in platoon mode in terms of lateral alignment goes through driving automation. In this sense, the Platooning Automated Function (PAF) will play a fundamental role in the future.

5.2.2 Economic and social

This section addresses the operation of heavy-duty vehicles in platoon mode from the economic and social points of view.

From the economic point of view, two main impacts have been identified that must be considered: the infrastructure and the regulatory framework.

On the one hand, as discussed in previous chapters, it is necessary to carry out improvements in the infrastructure. The development and implementation of platooning at the vehicle level must be accompanied by economic investments aimed at modernizing and improving European roads. The main objective should be oriented towards a better use of the infrastructure, thus improving its efficiency. In this sense, the development of communication networks that allow infrastructure monitoring will be necessary. In this way, road authorities could continuously monitor the traffic status of the road by vehicle type and ensure that the infrastructure is not overloaded by road freight vehicles. This is a relevant point, since overloaded infrastructures have negative impacts not only on society, but also on the economy (stress, accidents, infrastructure repair and so on). On the other hand, it would be interesting to approach this monitoring system from the point of view of data exchange between infrastructure and vehicles. In this way, it would be easily identifiable on which roads the platoon is allowed and what traffic restrictions exist. In addition, this data exchange could improve efficiency as it would allow candidate vehicles to be grouped together in platoon mode according to matching criteria based on logistical or operational data.

On the other hand, platooning should also begin to be considered from a regulatory point of view, with the economic impact that this implies. As stated in the previous section, the tests carried out in COMPANION and ENSEMBLE were carried out using a gap between vehicles of 10 to 30 m. However, it must be considered that the current regulations of European countries do not allow a circulation distance between vehicles of less than 50 m. In this sense, investments must be made at a European level to adapt and establish new regulations that allow the distance between vehicles to be reduced when they circulate in platoon mode (*Support or Automated Functions*). Finally, all regulations related to the cybersecurity of communication systems at the vehicle and infrastructure level should also be considered. Work must be done to ensure security in the exchange of data to avoid failures induced in these systems that put the security, not only of the systems but also of road users, at risk.

From the social point of view, two potential impacts have been identified that must be considered in relation to the circulation of heavy-duty vehicles in platoon mode: the acceptance of road users of this type of vehicle operation and the interaction between users and communication systems.

The acceptance of platooning by road users must be considered. In the first place, the drivers of heavy-duty vehicles that circulate in a platoon are directly impacted. As concluded from the results of ENSEMBLE, driving in platoon mode can lead to a reduction in average driving speed of up to 10 km/h.³² This aspect is relevant because it can lead to a rejection either by drivers or fleet operators. But the acceptance of platooning by other road users must also be considered. The entrances and exits of highways or overtaking a platoon are factors that can also cause rejection by these road users. Therefore, this type of social analysis should be deepened, especially in the path towards the automation of driving, where the role of drivers will still play an important role.

Finally, the human machine interface (HMI) between the road drivers and the communication systems that allow driving in platoon mode must also be considered. Especially in non-automated platoon traffic, that is, where the driver must still be present and alert to the traffic situation, human interaction with this type of system must be considered. The objective must be oriented towards the development of a user-friendly technology, which allows easy interaction and causes a good acceptance by the drivers.

5.3 Subtask 4.3: Feasibility assessment

This task considers a feasibility assessment in two different dimensions:

- Feasibility of platooning in different automation levels as a technology that is used in normal road traffic (section 5.3.1)
- The relevance of platooning with regards to consideration in Regulation (EU) 2017/2400 and VECTO (section 5.3.2)

5.3.1 Feasibility of platooning as a technology used in normal road traffic

The implementation of an operation of heavy-duty vehicles in platoon mode must be approached gradually with short, medium, and long-term objectives. Next, a roadmap proposal (Figure 103) is presented that reflects a possible implementation of the platoon progressively.

³² This problem is a fundamental one for platooning on road sections with significant longitudinal gradients. It could only be solved if the platooning infrastructure takes the power-to-mass ratio into account when grouping vehicles.

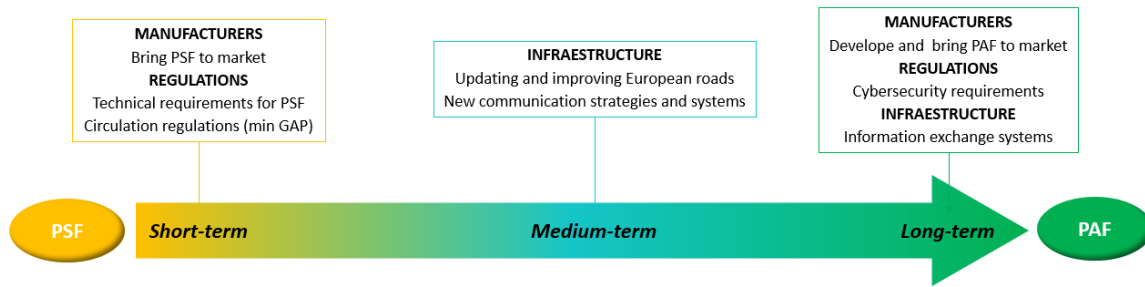

Figure 103: Roadmap proposal for platooning implementation in European roads

From a short-term point of view, efforts should be mainly focused on the vehicle level. As a result of the latest European projects developed, Platoon Support Function (PSF) technology is mature enough to consider an implementation in the coming years. From the point of view of vehicle manufacturers, they should focus their efforts on the final development of this technology, as well as its implementation in vehicles that will be launched on the market soon, in such a way as to allow road users to circulate in platoon mode in European highways. On the other hand, for the PSF to become a reality, work needs to be done in parallel in the regulatory field. Currently there is no regulation that establishes technical requirements for this technology. In this sense, the European authorities should focus their efforts on drafting new regulations governing this type of system. Technical requirements must be established to standardize this technology, in such a way as to guarantee the safety of all road users when circulating in platoon mode using PSF. Additionally, it will be necessary to review the road traffic regulations of the countries of the European Union. Currently in most countries, the traffic codes establish a minimum gap of 50m between vehicles on highways. The regulations need to be reviewed establishing the necessary exemptions that allow reducing the distance between vehicles when driving in platoon mode using the previously approved PSF technology.

The medium-term objectives will be marked by the prelude to driving automation. The pillars that allow the transition from Platoon Support Function (PSF) technology to Platoon Automated Function (PAF) technology needs to be established. In this sense, updating and improving European infrastructures will play a fundamental role. The main objective will be to achieve greater integration of the circulation of HDV in platoon mode on European roads. To do this, a more aggressive investment needs to be made to fully integrate the platoon with all road users and environment. For this, it will be necessary to develop and implement new communication strategies and systems at the infrastructure-vehicle level. This will allow road users to know in real time which roads are allowed to circulate in platoon mode, possible restrictions, and circulation alternatives. On the other hand, it must be considered that the main objective of PAF technology is to minimize the gap between vehicles, so all this must be accompanied by the improvement of road safety that allows all road users to safely circulate under these conditions. All these medium-term goals have two fundamental objectives. On the one hand, exponentially increasing the number of European roads on which HDV can circulate in platoon mode. On the other hand, these infrastructure improvements will significantly improve the efficiency of the European road network and, therefore, the efficiency of transport.

Finally, the long-term objectives should focus on the complete automation of platoon circulation. PAF technology, with a SAE 4 automation level, will play a key role. In this sense, in the coming years, manufacturers will have to work on the development of this new technology oriented towards autonomous driving. New communication and information exchange systems must be developed and implemented both at the level of vehicles and at the level of infrastructures that allow the implementation of autonomous circulation in platoon mode of HDV. At this point, cybersecurity will play a fundamental role. At the regulatory level, work should be done on new regulations that establish firm requirements on cybersecurity in relation to the

exchange of information. The integrity of this type of system against cyber-attacks must be guaranteed, as well as the software of these new communication systems being periodically updated.

5.3.2 Relevance of platooning for Regulation (EU) 2017/2400 and VECTO

Platooning should be considered as a relevant technology for Regulation (EU) 2017/2400 and VECTO in case:

1. vehicles equipped with such a system can be licensed to road traffic in the application period of the envisaged amendment (third amendment in the case of the current project), and
2. the effect on fuel consumption and CO₂ emissions is assessed to be of significance and can be either simulated in VECTO based on existing evidence or the technology is assessed to be "eligible", so that the VECTO implementation could be based on assumptions for the time being.³³

The presumed application period for the third amendment of Regulation (EU) 2017/2400 is in the years 2025/26 to approx. 2027/28. For these years it is estimated with regard to point 1. that first vehicles with PSF could be registered for road traffic. Vehicles equipped with PAF that operate in normal road traffic, on the other hand, are not considered realistic for this period.

Regarding point 2., it is clear that platooning can potentially have a certain impact on fuel consumption and CO₂ emissions. Two different ways in which such could be reflected by VECTO are detailed in subtask 4.4. However, it will not be possible to clarify representative operating conditions for platooning in the duration of the current project. These relevant operation conditions are:

- (1) Representative shares of kilometres driven on the motorway in which a vehicle equipped with the technology is actually in the platoon (with the limiting factors: other vehicles with such technology on the road, infrastructure available and road sections suitable, suitable traffic intensity or organisation of a platoon e.g. on a company level, acceptance by drivers and fleet operators, ...)
- (2) Platoon-related change in motorway driving speed compared to driving w/o platoon (e.g. due to power-to-mass effects or other legal framework conditions)
- (3) Driving shares in the platoon according to position (leader, intermediate, closing)
- (4) Average distance to the vehicle in front in the platoon

The order of the parameters as listed above corresponds to the importance of the parameter on the overall effect. The potential bandwidth of the overall effect on fuel consumption and CO₂ emissions in the VECTO longhaul Cycle ranges from "almost negligible" (few vehicles or low acceptance in use, no change in average speed) to approx. 5% (100% use, thereby approx. 10% fuel savings on approx. 50% of the motorway sections).

The following options are currently proposed by the project team for a treatment of platooning for the third amendment:

- 1) No consideration. Review of the topic at a later point in time, as soon as robust data for the technology in real driving operation is available. By then the methods as drafted in subtask 4.4 could be taken up and implemented based on actual operational data.
- 2) In case there are ambitions from the Commission and stakeholders to provide a bonus to this technology from the beginning: Implementation of platooning in the "simple" option outlined in subtask 4.4, with

³³ This approach was in the 2nd amendment of Regulation (EU) 2017/2400 pursued in the implementation of plug-in hybrids in VECTO, for which in particular the recharging profiles and thus the shares of electric driving are not known.

assumptions kept as simple as possible. The example parameterisation proposed in subtask 4 would result in a reduction of fuel consumption and CO₂ emissions of approx. 0.5% in the VECTO long haul cycle.

5.4 Subtask 4.4: Options for implementation in VECTO

In the following, two approaches are discussed on how modelling of platooning could technically be implemented in VECTO:

Option A) Simple

Option B) Advanced

Both options could be applied separately for different platooning technologies e.g. PSF and PAF, each parameterised with different operation conditions.

5.4.1 Option A) Simple

Option A) can only be applied under the conditions that platooning does not significantly change vehicle speeds driven compared to vehicles without this technology.

For the implementation, the following parameters are to be defined for each platooning technology:

- i. CdxA change in the platoon for the three possible positions (leader, intermediate, closing) based on the applied technology (mainly average distance dependent)
- ii. Share of kilometres driven on the motorway in the three positions

Table 36 below shows an example of such a parameter set for PSF. With regard to potential driving shares with platooning on motorways, these were assumed here as an example with a total of 30% (approx. 50% would be the maximum value in terms of infrastructure, a little more than half of these can actually be used). A platoon with 3 vehicles was assumed.

Table 36: Example parameters set option A for PSF

	Vehicle position			
	"Leader"	"Intermediate" (FV1)	"Closing" (FV2)	Outside of a platoon
$\Delta CdxA$	-2%	-10%	-8%	0%
share on km driven on motorways	5%	10%	5%	80%

This matrix could be used in the VECTO for the pre-processing of the CdxA value for the simulation of the motorway section. Based on these exemplary figures, a motorway average reduction of the CdxA value by 2% would result (sum product of the two lines). For a typical group 5 vehicle, this would result in fuel and CO₂ savings of around 0,5% in the long haul cycle.

Whether driving shares with platooning can also be assumed for regional delivery would have to be discussed separately.³⁴

³⁴ For regional delivery, about two thirds of the routes are also driven on motorways. The total trip lengths are relatively short at around 50 to 150 kilometres (long haul > 300 km).

This approach as proposed by option A would only be a very minor intervention in the VECTO simulation logic and would not require the separate creation of a driving cycle for vehicles with platooning. The inaccuracy effect of the simplified approach (given that the boundary condition with no speed changes vs. conventional vehicles applies) is certainly much smaller than the uncertainty regarding parameterisation of operational patterns. The overlap of platooning with PCC can also be neglected as long as a conservative parameterisation for platooning (i.e. sum of driving shares significantly below 50%) is defined. However, in the case of paper parameterisations for shares "in the platoon" from approx. 50% and above, the interaction of the two technologies would have to be investigated. For all vehicles that are not the leader vehicle, PCC is deactivated and the vehicle speed is controlled purely by the distance control to the vehicle in front.

5.4.2 Option B) Advanced

Option B is the simplest method identified if separate vehicle speeds are to be considered in the cycle for platooning. These would have to be explicitly implemented in the target speed trace of the VECTO mission profile. The representative driving share in the platoon needs also to be explicitly taken into account (precisely this part of the original cycle would have to be replaced by "platooning target speeds").

In the platooning part of the cycle VECTO would then have to apply the corresponding CdxA change in the simulation³⁵ and PCC would have to be deactivated in the simulation for this part.

Option B would be a much larger intervention in the VECTO simulation system and is only recommended for implementation if really robust data for the points (1) to (4) listed in section 5.3.2 are available.

³⁵ In Option B, the driving shares according to the positions "leader", "intermediate" and "closing" in the CdxA calculation would need to add up to 100%, as the platooning CdxA value is only used for the part of the cycle explicitly assigned to platooning and not for the entire motorway section, as is the case in option A.

6 Task 5: Open VECTO to user-defined control algorithms

The objective of this task was to investigate the feasibility of an updated VECTO version, capable of handling software and hardware in-the-loop (SIL & HIL) simulations.

As part of this task the contractor should:

1. Perform a feasibility study and analysis for introducing external control algorithms in future VECTO versions;
2. Identify necessary next steps towards VECTO software adaptation, external software certification and standardisation;

In the event that the feasibility analysis would give a positive result, further elements to be developed have been proposed in the ToR, most notably the development of a technical prototype that allows the use of user-defined control algorithms in VECTO.

6.1 Overview on the work performed

The feasibility analysis was already started in the first month of the project. Particular subject of the analysis was, whether the control algorithms as actually used in vehicles on the road could be coupled to the VECTO software in the context of the official application following Regulation (EU) 2017/2400. The conclusion of the analysis was that such a coupling is neither feasible nor even desirable for many reasons. This analysis is documented in section 6.2 of this report. The results were presented in a first step to the Commission (DG CLIMA and JRC) and afterwards to stakeholders on 8 June 2021. ACEA, in their feedback, as presented in the follow-up stakeholder meeting on 5 October 2021, agreed to this view. No official feedback has been received from other stakeholders.³⁶

In the follow-up to the feasibility analysis, further considerations were made on alternative approaches other than a 1-to-1 integration with which controller features can be taken into account in Regulation (EU) 2017/2400. These options are listed in section 6.3. These approaches are solutions that are already - at least partially - applied in Regulation (EU) 2017/2400. All options require a separate development and implementation effort, depending on the vehicle component or control technology under consideration.

In parallel to the activities described above, work on the development of a technical demonstrator for linking the official VECTO version with "external" control algorithms was performed. In this work, two strategies implemented in Matlab/Simulink (Case 1: An AMT gear shift strategy previously used in VECTO, Case 2: A highly simplified hybrid control strategy provided by ACEA as an example) were coupled with VECTO using the FMI/FMU methods. The technical methods developed and the conclusions drawn from this work are described in section 6.4. The methods and conclusions were presented to the DG JRC on 3 December 2021 and the developed software was handed over.

³⁶ However, as part of the feasibility analysis, the issue was also discussed bilaterally with some suppliers, who all came to the same conclusion.

6.2 Feasibility analysis on coupling of real controllers with VECTO

As already mentioned above, the subject of the feasibility analysis was to assess whether it is possible, to couple control algorithms as actually used in vehicles on the road to the VECTO software during generation of official results in the context of Regulation (EU) 2017/2400. In order for this to make sense, the following framework conditions were assumed as necessary premises:

1. It shall be the 1-to-1 controllers which are connected, and not re-worked derivatives of those
2. The process shall be precisely standardized in Regulation (EU) 2017/2400 and executable in a robust and transparent way by OEMs under the supervision of type approval authorities and the Commission

Point 1. is an issue because - if no adaptations are permitted to any algorithms - the procedure to be used (technical annexes and VECTO) must be universally applicable for all possible systems, software and architectures. As described further down below, this is considered as an impossible feature. Looked at from the other side, the admissibility of adaptations to the actual control algorithms would make no sense, because those would then – like the current generic VECTO controllers - not be the real controllers that were taken into account in the official results. Furthermore, it would be a questionable circumstance if vehicle manufacturers had to create a separate set of algorithms just for use in official VECTO.

Point 2 is a necessary prerequisite for all methods of generating official values with VECTO. In practical application, this removes all individually flexibility usually applied in complex engineering tasks required if models from different sources (here real controllers and VECTO) are to be integrated with each other to form a functioning overall system.

Based on these two points, in the development and application of VECTO a strict distinction must be made between "research and development" environment and methods to be applied in an official context. Below the identified reasons are listed, for which the any SIL or HIL applications in the process of Regulation (EU) 2017/2400 are assessed to be not feasible:

Reason #1: Principle limitations in possible system coverage

For realistic simulation results with an actual control algorithm, also the component models in the official VECTO version and the correlated component test procedures would need to cover the very specific design. Examples:

- Controls for "integrated complex" xEV architectures as the Scania GEM hybrid system³⁷: Covering those would additionally require OEM specific test procedures described in the technical annexes and a set of OEM specific physical model representations in VECTO.
- Controls of micro- and mild hybrids: This would require related time based modelling of the auxiliaries in VECTO and possibly in further consequence a certification for different auxiliary systems currently covered by the simplified generic VECTO approach (alternators, consumers like ventilation system, kitchen in a coach etc.)
- Advanced Driver Assistance System: Each OEM system uses specific map data (e.g. incl. curvature), information of traffic status, interaction with vehicle safety systems and other operational checks. Either specific representations of those would need to be elaborated for VECTO or the OEMs would need to be obliged to stick to the generic methods as provided by VECTO. The latter would of course

³⁷ The Scania GEM system is mentioned here because for this system a simplified generic representation in VECTO was developed ("IHPC Type 1").

be the worst case, as it would limit the quality of the systems on the road and freeze any further development.

Conclusions:

- ➔ all systems to be covered by the official VECTO SIL would additionally need OEM specific test procedures plus an OEM specific VECTO powertrain model and possibly additional sub-models
- ➔ none of the real vehicle controls would work in VECTO without major further extensions and modifications, most of them OEM specific

Reason #2: Handling of specific degrees of freedoms

Complex vehicle control systems also require extensive parameterisation. For certain systems, e.g. ADAS, some of the settings can also be influenced by the driver. Especially for new systems that are not yet generically defined in VECTO (e.g. the ADAS feature “pulse and glide”), those parameters for the simulation would have to be agreed individually between the OEM and the type approval authority. This may work for some cases (e.g. demonstration that the parameters correspond to the factory or key-off/key-on settings), but in some cases may lead to unpredictable uncertainties in the results. For example, in the case of pulse and glide in combination with predictive cruise control (PCC), it would be necessary to investigate how the control parameters are to be set so that the comparability of the results with other manufacturers who use the generic representation of PCC in VECTO is still given.

For entirely new technologies, all model parameters and boundary conditions in the simulation would have to be negotiated entirely between the type-approval authority and the OEMs. This will lead to non-comparable results for similar technologies at different OEMs. This is completely contrary to the basic principles of a functioning and transparent Regulation (EU) 2017/2400, in which all technology assessments should be coordinated at EU level between the Commission and stakeholders. The latter, however, would be in fundamental contradiction to the VECTO SIL/HIL system under investigation here, as many of the algorithms and the individually calculated savings potentials would be subject to confidentiality.

Reason #3: Principle limitations regarding verification possibilities

In Regulation (EU) 2017/2400, there are currently two levels of verification:

- a) It must be demonstrable that a particular component, feature or technology is actually present in the vehicle as declared.
- b) The CO₂ or energy consumption level shall be verifiable in a VTP.

Regarding a), it would have to be investigated whether this could be done purely at the software level (e.g. via a hash of the compiled software). In any case, separate methods would have to be developed for this purpose. Difficulties will arise due to the necessary family concepts for the software, since it cannot be assumed that each individual vehicle is simulated with its concrete software in the official certification (see reason #7 on simulation time). Verification via a comparison of on-road tests – via a comparison of system behaviour in the measurement and in the simulation - is considered to be impossible because

1. The boundary conditions in the official VECTO simulations can never be reproduced 1:1 in an on-road measurement.
2. because of the limitations from reason #1, the simulation model in VECTO is also subject to fundamental limitations

Thus a direct match of comparison of signals from an on-road test and a VECTO simulation can never occur and concluding from that the in a) desired verification that the correct software is on board is not assessed to be feasible.

This consideration leads directly to the VTP test b), in which, the CO₂ emissions are to be verified. For this purpose, VECTO uses a specially developed VTP mode in which the measurement is recalculated in an explicit backward simulation approach³⁸ in order to enable a direct comparison of measured and simulated CO₂. The inclusion of SIL/HIL in such a VTP mode seems difficult or even impossible from the point of view of the authors. In any case, a VECTO VTP SIL/HIL mode would be a separate development project.

Reason #4: Principle limitations regarding “accuracy” or “resolution” for an official certification procedure

At a certain point increasing the complexity in a standardized model is assessed to be not appropriate from a scientific point of view. Any resulting fine differentiation between vehicle configurations will mainly result from the general assumptions made in some details in the model or from some debatable boundary conditions of a test procedure. For this reason, artefacts would be unavoidable in highly complex VECTO if a certain detail is added to one side of the model without being able to make adjustments to other subsystems that are standardised. From the authors' point of view, the upper limit of a reasonable complexity of VECTO has already been reached for some vehicle configurations (example: modelling of combinations of hybrid electric vehicles and bus auxiliaries taking into account that the factor method has to be applied). Thus adding even more complex sub-models, as it would be unavoidable for SIL/HIL applications, does not seem advisable from a scientific point of view.

Reason #5: Technical feasibility restrictions – set of required signals

In order to couple a real vehicle control system to VECTO, a vast number of signals i.e. model quantities not part of the standard VECTO model would need to be provided and standardized. The elaboration of such a cross-OEM standard is assessed to be a big challenge and would need to be - if at all successful – a permanent ongoing task.

Such a standardization could theoretically be simplified if much freedom would be given to the manufacturers to provide missing signals by own interfaces (the so-called “rest-bus”). Such a rest-bus can significantly influence the results. As for several of the above mentioned reasons this however puts in question the entire approach as:

- The basic idea to have the “real vehicle controls” reflected in the official results would be undermined
- The VECTO result would to an unknown extend depend on the logics developed by the OEMs specifically for the “rest-bus”

As a further countermeasure, one could define stricter verification provisions. But such is also not assessed to work out, see reason #2).

Reason #6: Technical feasibility restrictions – Software and model architecture issues

A simulation tool which shall be compatible to real controllers is assessed to be of “forward architecture”. Thus a complete new development of the VECTO core would be needed.

A pure forward architecture is assessed to have many disadvantages in a certification context compared to the tailor-made VECTO architecture, which combines the advantages of “forward” and “backward” architecture. Thus for example VECTO avoids fundamental comparability problems of forward models in the amount of a least few tenths percent CO₂ due to the different behaviour of a standardised forward driver controller for various vehicle configurations. It would also need to be considered how, in the case of such a new VECTO

³⁸ In contrast, VECTO's simulation approach in the Declaration mode is a nested approach with forward and backward elements.

development, vehicles to be calculated without SIL/HIL application are to be handled. Should these then also be simulated by the VECTO forward tool? In the case of "yes", this would unavoidably trigger an adjustment procedure for the CO₂ standards. In the case of "no", two different VECTO tools would have to be operated in parallel with support and maintenance.

It is furthermore very questionable whether any single model architecture and component structure can be compatible to any possible real vehicle controller (e.g. a 10Hz version required for certain controllers, e.g. driving dynamics and up to 10 kHz version for others, e.g. including ICE controllers).

As a further issue identified, full compatibility with the de facto industry standard Matlab/Simulink would be required. This is a special issue for VECTO, because no commercial licences may be used. This means that an open source solution would have to be targeted. Such libraries are available in principle (e.g. GNU Octave), but it is questionable whether complete compatibility with the Matlab/Simulink versions used by vehicle manufacturers can actually be achieved.

Reason #7: Technical feasibility restrictions – Simulation time issues

Current VECTO versions have a "speed-up" factor³⁹ of up to 6000 (for conventional vehicles) and some 150 (for HEV), considering the VECTO features enabling multi-threaded execution on a single computer. Thus, the calculation time of the current VECTO approach in the official application for a single vehicle is in the range of approx. 30 seconds (group 5 – long haul vehicle) to approx. 30 minutes (heavy bus, factor method, PHEV).

Contrary, if in a typical case a SIL environment is operated in real-time, simulation times for a single vehicle would be in the range of 20 hours (group 5 – long haul vehicle) to 4 days (heavy bus, factor method, PHEV). Worst case SIL simulation systems do even operate slower than real time.

Reason #8: Operating, support, maintenance and expansion costs at official institutions

For any such complex simulation environment significantly enhanced resources for operating the system including support, maintenance and further development costs are expected.

Those costs would not only affect the tool (CLIMA) but also legislation support (GROW) and especially type approval authorities, which would need to accompany OEMs applying SIL/HIL and guaranteeing a correct application.

Reason #9: Costs at manufacturers

Assuming that all the previous problems could be solved, the implementation of the methods would cause high costs for the manufacturers. It is estimated that own teams would have to be deployed for this. This would also result in a considerable disadvantage for small manufacturers who would then not be able to take this option for cost reasons. Their CO₂ values from VECTO would be worse in this case, but this would not necessarily be related to the performance of the vehicle.

Conclusions

From the above arguments, it is concluded that the generation of official CO₂ values with VECTO, taking into account the specific software used in the vehicle, is neither technically feasible nor even desirable. The latter is mainly due to the fundamental lack of transparency associated with this, the high costs for the Commission and manufacturers and the associated systematic discrimination against small manufacturers.

³⁹ This is the ratio of real time to simulation time

6.3 Alternative approaches for controller consideration

Based on the negative result of the feasibility analysis for the 1-to-1 integration approach as originally aimed at, alternative ways were explored as to how the influence of smart control algorithms for components or the complete vehicle could nevertheless be taken into account in VECTO. Those options are described below. All identified approaches are solutions that are already - at least partially - applied in Regulation (EU) 2017/2400 and require a separate development and implementation effort, depending on the vehicle component or control technology under consideration.

Option A: Implicit consideration of controls via component test procedures and component input data.

This "back box" approach is already used in VECTO for the modelling of the extremely complex transient behaviour of internal combustion engines. For this purpose, using the certified engine dyno data recorded both stationary and transient, correction factors are determined by the engine pre-processing tool, which are then assigned to the mission profiles in VECTO using sets of weighting factors.

In the future, in case required necessary, such an approach could be used in the modelling of "complex" e-powertrains (e.g. for IEPCs) To do this, one would have to expand the currently only stationary energy consumption measurement to include transient cycles as well.

Option B: Via control technology definitions and generic modelling in VECTO

This option is already being used in VECTO, for example for smart auxiliaries and for a variety of different ADAS systems (e.g. predictive cruise control).

In the future, this approach could be used, for example, for other smart controllers, provided that their function can also be proven in the vehicle, at least theoretically, with a reasonable amount of effort. A conceivable example of this would be "predictive SOC control", in which a hybrid controller takes the topography into account and drains the battery up to the top of a climb in order to be able to store more energy via recuperation when driving downhill. Such an approach would be easy to demonstrate in a vehicle and could also be implemented into the generic VECTO hybrid controller.

Option C: Declaration of high level control parameters in the VECTO input, which are then considered by the generic VECTO control strategies

This option is also already used in VECTO. Examples are the gear dependent torque limits ("Top torque") and the boosting limitations as can be declared for parallel hybrids. As with option B, care must be taken to ensure that the parameters to be declared can at least theoretically be verified in a vehicle measurement.⁴⁰ Option C was furthermore considered in principle when developing the methods for ADAS (e.g. OEM specific declaration of values for speed hysteresis, preview distance etc⁴¹). This declaration option was however discarded at a certain point, as the definitions of the parameters and necessary simplifications compared to the actual controllers as well as the safeguarding through control on the vehicle were considered too complex.

⁴⁰ For the gearbox torque limitations, such provisions are already part of the VTP. For the boosting limits, such provisions would have to be worked out in the development of a VTP for xEV. For such the feasibility was assessed to be given once the declaration approach has been decided on.

⁴¹ Details see **Fehler! Verweisquelle konnte nicht gefunden werden..**

6.4 Development of a technical demonstrator

Using an external software module or hardware component in a simulation environment is called model-in-the-loop (MiL), software-in-the-loop (SiL), or hardware-in-the-loop (HiL), depending on the type and granularity of the external component. The main aspect in all cases is that one simulation instance is the master, and the other component is called by the master. As the VECTO simulation tool controls the whole simulation flow, it is mandatory that VECTO acts as the master instance.

There exist different tools for MiL, SiL, HiL simulations. As VECTO is published under the EUPL, the used in-the-loop simulation approach has to be compatible with the VECTO license. Many OEMs use Matlab/Simulink for the development of their controllers and develop their own simulation tools in Matlab/Simulink. Matlab/Simulink allows to connect with other simulation tools and exchange data in different technical means (TCP/IP connection, RPC, IPC, RESTful webservices, ...). Using this approach would imply that all OEMs need to develop their controller in Matlab/Simulink or port their existing controllers from some other software to Matlab/Simulink. Moreover, the license compatibility with the EUPL is unclear.

Therefore, we decided to use a more general approach for connecting external control software to VECTO and use the Functional Mockup Interface (FMI) standard. FMI describes an interface standard for simulation tools and provides functions to communicate with models, setting the inputs, and reading the outputs. With this standard, multiple models can be simulated and an algorithm can exchange the data between those models.

The Functional Mockup Unit (FMU) is in a simplistic way a wrapper over a shared library (DLL), which is a single model in the FMI standard. A FMU is still a shared library, but with additional code of the FMI standard to define the inputs, outputs, parameters, and functions to run the model. An FMU can be used in different target environments, such as Windows, Linux, or macOS as no specific header files are used. This allows to exchange the FMU cross-platform.

A FMU consist of a single ZIP archive which contains the following data:

- XML file: information about the model, its inputs and outputs, parameters and FMI specific settings
- Binary files (DLLs)
- Source code (optional)
- Additional files

A Functional Mockup Unit can be created with various tools as long as it complies to the FMI standard or programmed manually in C code with tools such as “FMU SDK” by Synopsys [95] or the “FMU SDK” by Qtronic [96]. There exist tools to verify the validity of an FMU. Even for Matlab/Simulink multiple commercial and free tools exist to export models into Functional Mockup Units (e.g., Modelon FMI Toolbox for Matlab/Simulink [97], Easy FMI Add-On for Matlab/Simulink [98], FMIKit-Simulink [99])

For this technical demonstrator “FMIKit-Simulink” has been used as it is a free solution and actively maintained on Github. One drawback is that not all Matlab/Simulink functions can be used when the model is exported as FMI/FMU. But with every major Matlab/Simulink version more functions become available.

To demonstrate the technical feasibility two different strategies have been implemented in Matlab/Simulink and exported to FMI/FMU as described later on in sections 6.4.2 and 6.4.3.

A ZIP archive containing both demonstrators (VECTO source code, Matlab/Simulink source code, documentation) has been uploaded to the CodeEU platform⁴². The branches of the source code are available

⁴² <https://code.europa.eu/vecto/vecto/-/packages/1419>

on the CodeEU platform as well. The VECTO source code for the FMI shift strategy can be found here⁴³, and the source code for the FMI hybrid strategy demonstrator can be found here⁴⁴.

6.4.1 VECTO and FMI

In the current implementation, strategies in VECTO (e.g. driver strategy, gearshift strategy, hybrid strategy) are rather closely connected to the other components in the simulation model. For example, the gearshift strategy may issue so-called “dry-run requests” to the powertrain in order to assess an operating point in a different gear and then decide whether a gearshift is necessary and possible. And the strategies can obtain information about all other components in the powertrain via the so-called “DataBus”. This “two-way communication”, i.e., that a strategy calls certain methods of other components is no longer possible when a strategy from an FMU is used. This means, that all necessary information from other components on the DataBus need to be passed to the FMU in every simulation step.

Another limitation when using a strategy in an FMU is that only a single method can be called. In VECTO, a strategy has at least two public methods defined in its interface, namely to initialize the model and to handle the requests, but some strategies expose additional public methods in their interface. As there is only a single method in the FMU, there is also only a single return value (which can be an array to return multiple values). But this needs to be considered when overcoming the limitation that only a single method is exposed by the FMU. As there is only one method in the FMU to be called, the different public methods of a strategy need to multiplexed into a single method call. This means that the first parameter of the method identifies which method of the strategy interface was called. And depending on the called method, the return value needs to be read from a different position in the returned array.

VECTO is implemented in C# on the Microsoft .net platform. This means, that the code is compiled into an intermediate language (IL). At run time, a just-in-time compiler (JIT) compiles the intermediate language into native code for the local machine. The FMU, on the other hand, is directly compiled into native code. This means that the FMU code cannot be called directly. The function headers of the DLL need to be re-defined in C# and a wrapper is needed to call the C DLL in the correct way. Fortunately, such a wrapper to call an FMU from C# is already available under a public license. The “FmiWrapper” [100] has already all the interface calls to the C DLL and provides easy-to-use functions in C# to call the FMU.

Further necessary adaptations in VECTO are to implement a stub component for the strategy that shall be replaced by the FMU. This stub implements the interface required in VECTO so that it can substitute the original VECTO strategy. The different methods defined in the interface are then multiplexed into a single call to the FMU. Moreover, the stub implementation aggregates all necessary information from the DataBus and passes this over to the FMI wrapper and finally to the FMU. The stub implementation then calls the FmiWrapper which passes over the method call from C# to C. The C counterpart of the FmiWrapper finally calls the method in the FMU. The return values from the FMU eventually end up at the stub implementation which uses the correct entries from the array of returned values.

Figure 104 depicts how a strategy is connected to a powertrain component in VECTO if the strategy is part of VECTO. The orange arrow indicates that the communication between the powertrain component and its strategy can be bi-directional, i. e., the strategy can call functions from the powertrain component or access other powertrain components via the DataBus.

⁴³ https://code.europa.eu/vecto/vecto/-/tags/Project_VECTO_FD_IL%2FFMI%2FAMTShiftStrategy

⁴⁴ https://code.europa.eu/vecto/vecto/-/tags/Project_VECTO_FD_IL%2FFMI%2FAMTShiftStrategy

Figure 105 shows how a strategy implemented as FMU is connected to a VECTO powertrain component. The stub implementation still has bi-directional access to the other VECTO components, but any other calls towards the FMU via the different wrapper instances are then unidirectional, i. e., the FMU is not able to access other VECTO powertrain components or the DataBus.

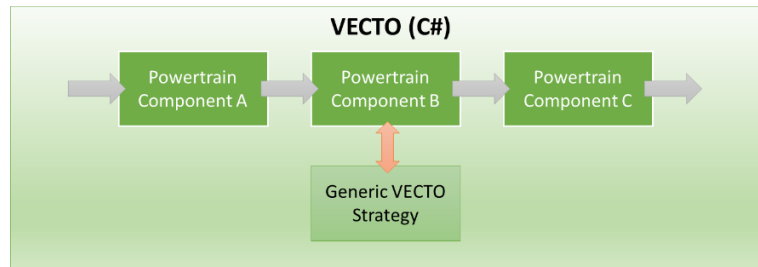

Figure 104: Strategies in VECTO without FMU

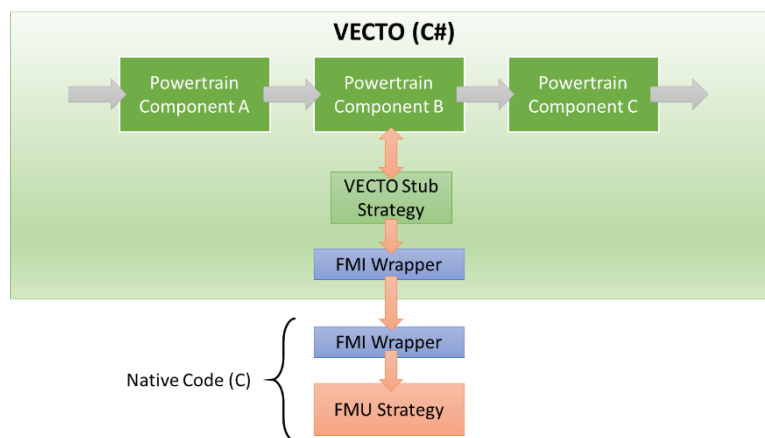

Figure 105: VECTO with FMU strategy

6.4.2 Case 1: Implement the generic VECTO shift strategy as FMU

The first demonstrator to analyse the technical feasibility to connect a strategy implemented as FMU to VECTO is the AMT shift strategy. The generic AMT shift strategy is part of the VECTO implementation, based on rather simple rules, and well understood. Therefore, this is a good first candidate to investigate on the technical feasibility.

The generic AMT shift strategy is based on gearshift lines (upshift line, downshift line) for each gear. If the current ICE operating point is “above” the upshift line, an upshift is triggered; if the ICE operating point is below the downshift line, a downshift is triggered. As the AMT shift strategy is allowed to skip one or two gears during a gearshift, the strategy evaluates the ICE operating point in potential next gear and chooses the best gear depending on several rules. Moreover, the AMT shift strategy may trigger an early upshift (i. e. the current ICE operating point is within the upshift/downshift lines) if the ICE operating point in a higher gear is valid and provides sufficient torque reserve. To assess the ICE operating point in different gears, the strategy issues several “dry-run requests” to the VECTO powertrain components. More details on the AMT shift strategy are provided in the VECTO User Manual of versions before 3.3.11.

The first step was to model the generic VECTO AMT shift strategy in Matlab/Simulink. While the generic VECTO shift strategy calculates the shift lines for every gear depending on certain vehicle parameters (dynamic tire radius, axle gear ratio, engine full-load curve, gear ratios, etc.) the FMU implementation is typically specific for certain vehicle configurations. Therefore, it is assumed that these parameters are in a practical application hardcoded into the FMU. However, as we tested the FMU shift strategy with different vehicle configurations, our approach was to read the necessary parameters (e.g., shift lines) from a configuration file during the initialization.

To assess the ICE operating point in different gears it was necessary to implement certain powertrain components in the FMU shift strategy in a simplified form. These were essentially the gearbox and the combustion engine. For the gearbox the transmission ratios and loss-maps of all gears are necessary, for the combustion engine the inertia and full-load curve are relevant. These model parameters are read from the same configuration file.

Figure 106 shows the graphical representation of the shift strategy model in Matlab/Simulink. Most parts were implemented as S-function as this simplified porting the code from VECTO to Simulink.

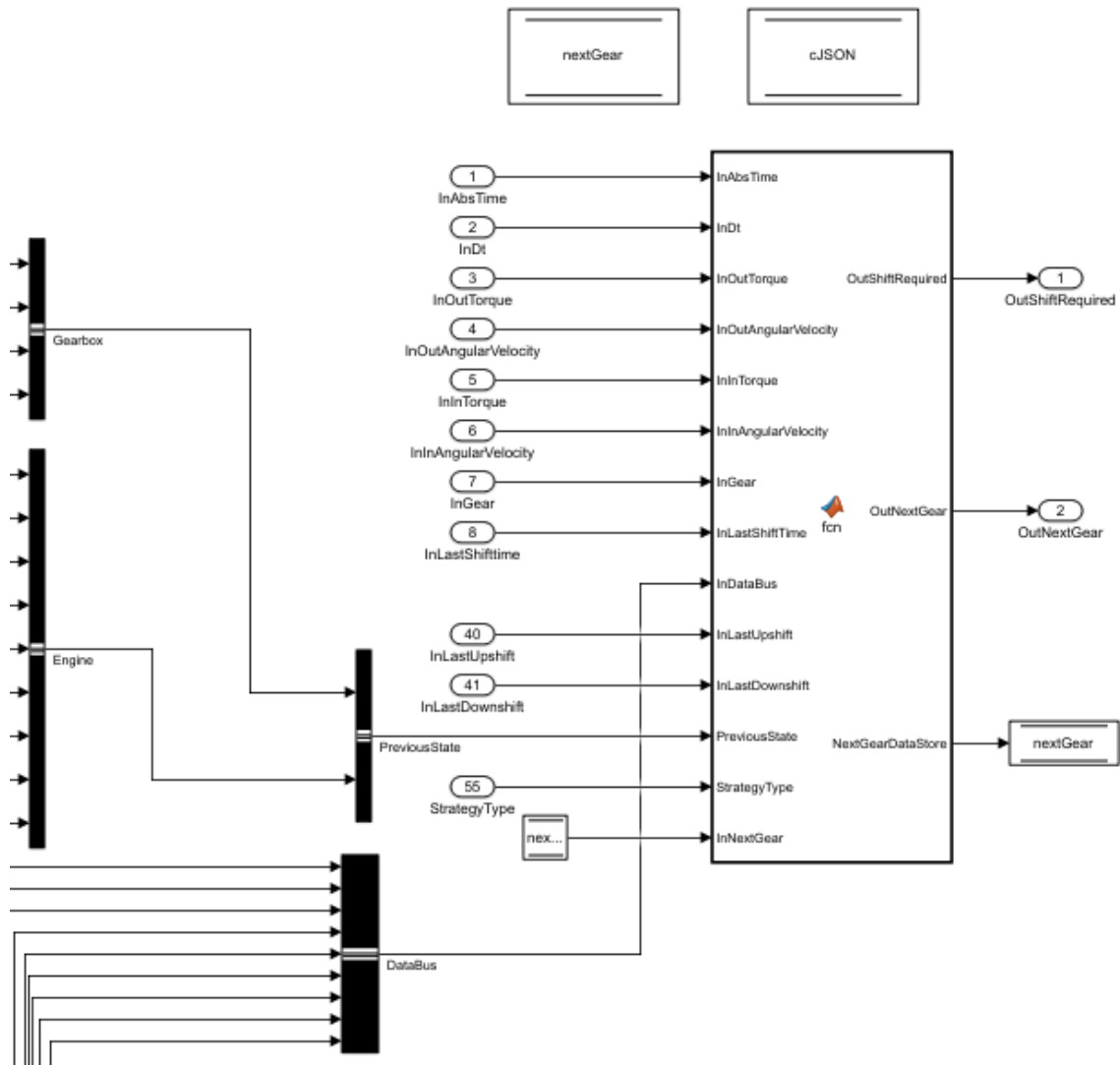

Figure 106: Graphical representation of the shift strategy model in Matlab/Simulink

The implementation of the FMU shift strategy was compared to the generic VECTO AMT shift strategy by extracting several driving situations from a VECTO implementation. The FMU shift strategy shall make the same decisions whether to trigger a gearshift or not.

In a next step the signals required by the shift strategy were identified. This includes the internal state of the gearbox, the internal state of the combustion engine, and certain signals from the DataBus. All these signals have to be added to the Matlab/Simulink model so that the generated FMU accepts the correct input parameters. A shift strategy stub was implemented in VECTO to gather all the required signals and pass them on to the FMU. The return values from the FMU (shift required and the next gear to use) is used in the shift strategy stub and provided to the other powertrain components as defined in the public interface.

6.4.3 Case 2: Connect ACEA HEV control strategy to VECTO

The second demonstrator shows that also a more complex strategy, namely the control strategy for a parallel hybrid vehicle can be implemented as an FMU. In this demonstrator a completely different control strategy

than used in VECTO was implemented. A model of a simple hybrid control strategy provided by ACEA already as Matlab/Simulink model was compiled into an FMU and used in VECTO. Figure 107 shows an overview of the ACEA hybrid control strategy. The basic idea of this strategy is to maintain a constant SoC, recuperate whenever possible, and only use recuperated electric energy for propulsion. The output of the hybrid strategy is how much torque the electric motor and how much torque the combustion engine provide to propel the vehicle.

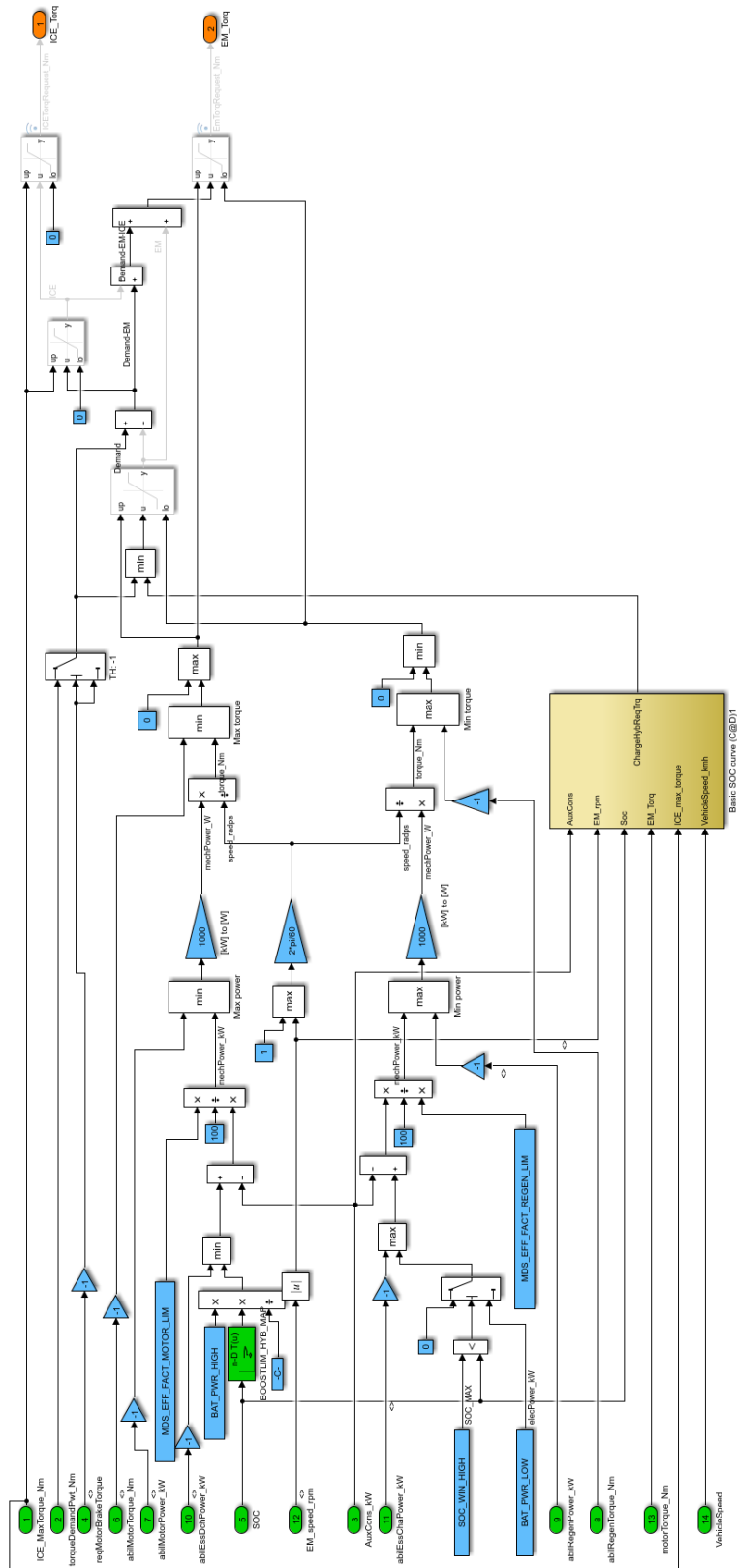

Figure 107: Matlab/Simulink model of the ACEA hybrid strategy

The generic hybrid strategy implemented in VECTO is based on the ECMS approach. It evaluates different combinations of torque-split between electric motor and combustion engine for different gears. Out of these combinations, the one with the best score is selected. This means that the hybrid strategy provides both, the gear selection and the torque provided by the electric motor.

Hence, the hybrid strategy interface contains methods for both signals, the gearshift and electric motor control. As the ACEA hybrid strategy does not contain the logics for gear selection, we extended this model by the shift strategy implemented in case 1, with some extensions to handle certain situations in the hybrid powertrain.

The ACEA hybrid strategy is designed for a forward-calculating model. VECTO, however, is implemented as backward-calculating simulator. Therefore, several tweaks were necessary to use the forward-calculating hybrid strategy in VECTO.

Moreover, not all signals required by the ACEA hybrid strategy are directly available in VECTO and certain signals used a different convention than VECTO or different units of measure (rpm vs. 1/s, kW vs. W, ...). For the technical demonstrator the conversion of certain signals so that it fits the required inputs of the ACEA hybrid strategy was done in the stub implementation. The stub implementation in this case is a little bit more complex than in the first demonstration as the hybrid strategy on the one hand controls the electric motor and on the other hand decides on the gear shifting.

The two demonstrators described (cases 1 and 2) were developed functionally as part of the work, demonstrated to DG JRC in a workshop and handed over. Quantitative results of the simulations are basically not relevant in this context, as it was only a matter of analysing the feasibility of the technical methods for model coupling. In any case, it was demonstrated for Case 1 that the reconstruction of the old AMT gear shifting strategy from VECTO in Matlab and the coupling via FMU achieves the same results as the original VECTO implementation.

6.4.4 Conclusions

The two demonstration cases show that it is at least in principle technically feasible to use strategies implemented in an external module. The FMI standard can be used to connect this external module typically available in native code to the VECTO simulator implemented C# on the .net platform. FMI is a general open standard for simulation models and different tools can be used to generate a functional mockup unit (FMU), Matlab/Simulink is among those.

The overhead in terms of simulation time when calling an external strategy is negligible. What has more influence in the overall simulation time is the actual implementation of the FMU. For example, if the generated code uses dynamic memory allocation instead of static memory allocation the simulation time increases. And the more complex the decision-making process of a strategy is, the longer the simulation time will be.

The two use cases described in the sections above show the technical feasibility in two concrete examples where the strategies to be implemented as FMU were known to the VECTO developers, the controller algorithm and the VECTO architecture are compatible, and the models and source code were available. Hence, the necessary wrapper classes, signal conversions, calling semantics are tailor-made for these specific use cases.

However, no generally valid technical feasibility can be derived from this work. The purely technical limitations already described in the previous section (Reason #5 - set of required signals, #6 - software and model architecture issues and #7 - simulation time issues) still apply without restrictions.

In addition, the other reasons for exclusion described in section 6.2 speak against the application of the method analysed in this particular section on the purely technical level within the framework of the calculation of the official CO₂ values.

7 Task 6: Technical support

The scope of Task 6 was to:

1. Be responsible throughout the duration of the contract for addressing issues and fixing bugs occurring from the changes performed in VECTO as part of the activities stipulated in this contract.
2. Ensure a smooth functioning of the VECTO tool and adjacent software throughout the period of this contract. While VECTO will be downloadable software that shall be run independently by each HDV manufacturer, bugs or inaccuracies shall be corrected.
3. Reserve 50 working days, during the duration of the whole contract, for further technical support in order to update or develop certain modules of the tool for certification purposes, if needed.

The entire work process related to Task 6 was organised via the ticket system in CITnet JIRA and - from spring '23 after the migration of the IT system on the commission side - GitLab / code.europa.eu. In terms of technical content, the above points 1. and 2. are directly assigned to the method development as to be carried out under Task 1, Task 2 and Task 3 and were carried out accordingly. Point 3. is clearly separate from this, as the related content is general, i.e. covers maintenance and support needs regarding elements not developed in this contract as well as the implementation of additional technical content not yet known at the beginning of the project. As agreed with DG CLIMA, resource accounting did not start at the beginning of the project, but only from 1 July 2022, after the working days quota of the predecessor project was closed on 30 June,

The resources allocated to point 3. (a total of 50 person days) were monitored using exports scripts from CITnet JIRA and GitLab / code.europa.eu. A detailed list of all tickets and the resources required for them can be found in document `Task6_ListTickets.xlsx`. In the following, the types of activities and the timing of the work are analysed.

Figure 108 shows the breakdown of work - by number of days worked and by count of tickets processed - by type of activity. Most of the working time (approx. 45%) was spent on the on-demand implementation of new content or improvements. Bug fixes in existing features follow with just under 30% of the working time. With regard to the figures for Article 10(2) notifications⁴⁵, it is important to note that the value only includes the time for processing tickets, running jobs and analysing what needs to be done. If necessary, fixing bugs has been assigned to the "bug fixes" category. The user support category includes the most tickets with 35 requests, but with relatively small amount of working time.

⁴⁵ This is a process in which vehicle data that does not pass through the official calculation of CO₂ values in the tool is reported via JIRA. Based on the notification, a classification is made, e.g. whether it is an error in the tool or in the input data, and the next steps are organised,

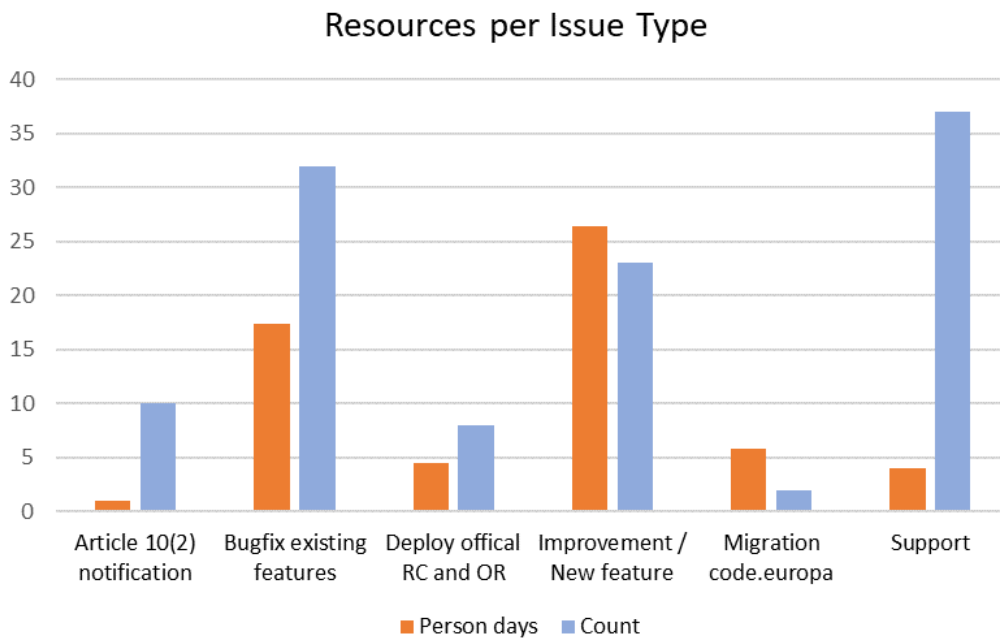

Figure 108: Task 6 item 3: Resource consumption per issue type

Figure 109 shows the breakdown of work by tool. VECTO (the vehicle simulation tool) itself accounted for over 80% of the work. The category "general" mainly includes the migration to code.europa.eu.

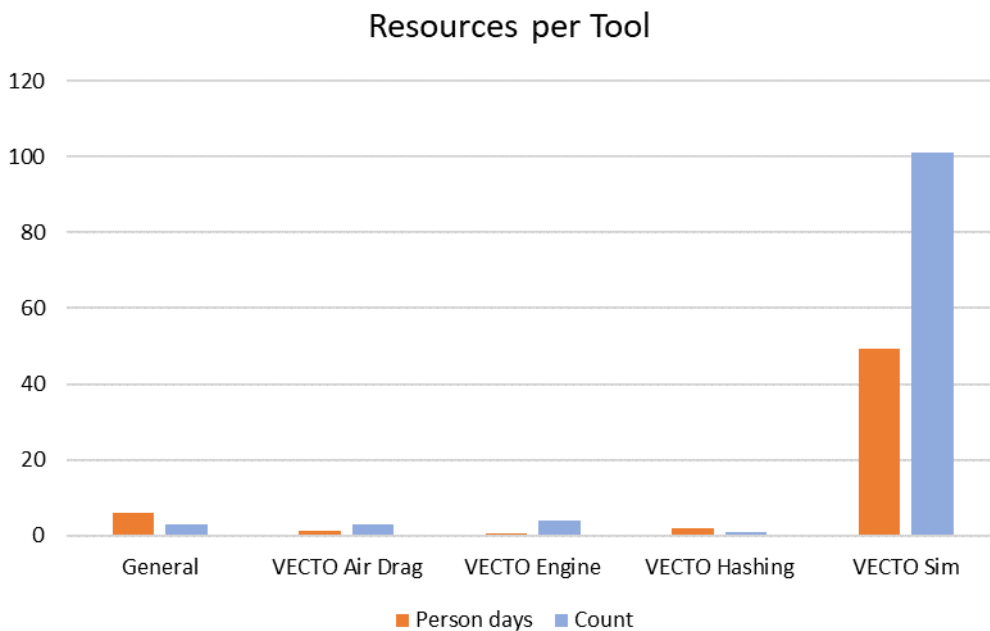

Figure 109: Task 6 item 3: Resource consumption per tool

Finally, Figure 110 shows the chronological history of the work done in Task 6 item 3. Towards the end of the contract period, an increase in the required resources can be seen due to:

- The approach of the application period of the 2nd amendment methods and the associated increase in general enquiries and bug reports for all methods used in VECTO.
- Necessary follow-up work on the 2nd Amendment VECTO tool versions in areas not covered by specific contracts, e.g. XML, official reports and hashing.

In this context, it is expected that support and maintenance efforts for the official VECTO will further increase in autumn/winter 2023/24.

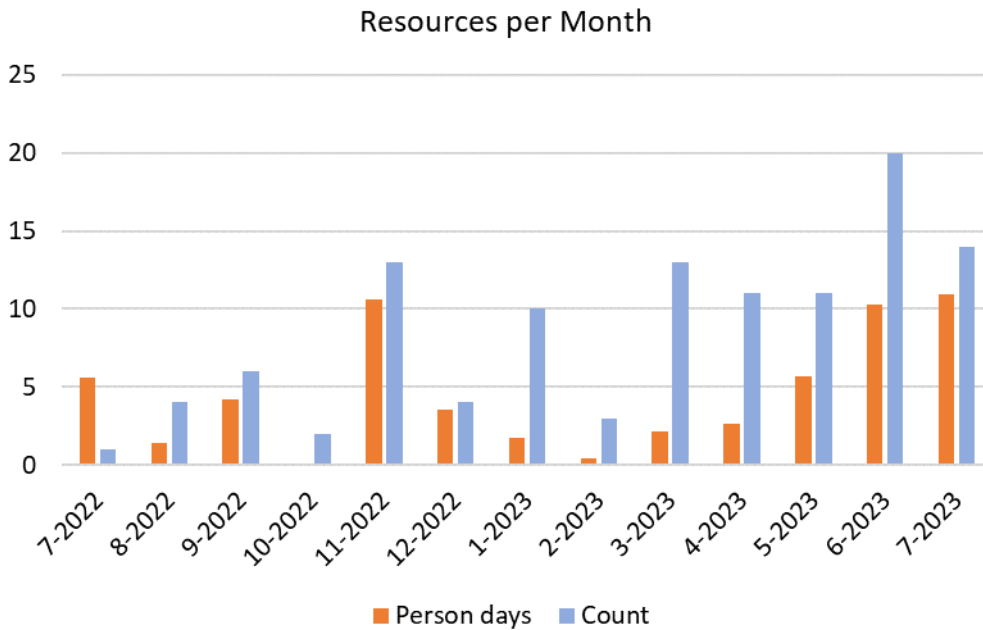

Figure 110: Task 6 item 3: chronological resource consumption

8 Meetings

Table 37 lists the main meetings held with the Commission and stakeholders during the project duration.

Table 37: Meetings held during the project

Date	Location	Participants	Topic
2020-12-11	Audioweb	DG CLIMA, DG JRC, TUG, Emisia, HyCentA, Idiada, Tecnalia	Inception Meeting
2021-02-02	Audioweb	ACEA, Emisia, TUG	Task 1
2021-04-21	Audioweb	DG CLIMA, DG JRC, DG GROW, ACEA, CLEPA, CLCCR, ETRMA, TUG, Emisia, HyCentA, Idiada, Tecnalia	Introduction of the project to the VECTO board
2021-05-31	Audioweb	DG CLIMA, DG JRC, TUG, Emisia, HyCentA, Idiada, Tecnalia	Pre-meeting with COM on content to be presented in upcoming stakeholder meeting
2021-06-08	Audioweb	DG CLIMA, DG JRC, DG GROW, ACEA, CLEPA, CLCCR, ETRMA, TUG, Emisia, HyCentA, Idiada, Tecnalia	Dedicated stakeholder meeting for Tasks 1 to 5
2021-07-09	Audioweb	HyCentA, TUG, DG CLIMA, DG JRC and stakeholder members of the TF-FCS	Task Force Fuel Cell Systems (TF-FCS) #1
2021-09-24	Audioweb	TF-FCS members	TF-FCS #2
2021-10-01	Audioweb	DG CLIMA, DG JRC, TUG, Emisia, HyCentA, Idiada	Pre-meeting with COM on content to be presented in upcoming stakeholder meeting
2021-10-05	Audioweb	DG CLIMA, DG JRC, ACEA, CLEPA, CLCCR, ETRMA, TUG, Emisia, HyCentA, Idiada	Dedicated stakeholder meeting for Tasks 1 to 5
2021-10-22	Audioweb	TF-FCS members	TF-FCS #3
2021-11-09	Audioweb	DG CLIMA, DG JRC, TUG	Preliminary discussions on Task 1.4 (Adjustment procedure)
2021-10-22	Audioweb	TF-FCS members	TF-FCS #4
2021-12-01	Audioweb	DG CLIMA, DG JRC, ACEA, CLEPA, CLCCR, ETRMA, TUG, Emisia, HyCentA, Idiada	Dedicated stakeholder meeting for Tasks 1 and 3

Date	Location	Participants	Topic
2021-12-03	Audioweb	DG JRC, TUG	Task 5 – VECTO FMI
2021-12-10	Audioweb	TF-FCS members	TF-FCS #5
2022-01-11	Audioweb	DG CLIMA, DG JRC, ACEA, CLEPA, CLCCR, ETRMA, TUG, HyCentA, Idiada	VECTO xEV Workshop #9 (Task 3, how to handle in-motion charging vehicles)
2022-01-26	Audioweb	DG CLIMA, DG JRC, ACEA, CLEPA, CLCCR, ETRMA, TUG, Emisia, HyCentA, Idiada	Dedicated stakeholder meeting for Tasks 1 (Long haul update) and all other aspects of the related major VECTO 2022 update
2022-01-28	Audioweb	TF-FCS members	TF-FCS #6
2022-02-11	Audioweb	TF-FCS members	TF-FCS #7
2022-02-16	Audioweb	DG CLIMA, DG JRC, ACEA, CLEPA, CLCCR, ETRMA, TUG, Idiada	VECTO xEV Workshop #10 (Task 3, how to handle in-motion charging vehicles)
2022-03-16	Audioweb	DG CLIMA, DG JRC, ACEA, CLEPA, CLCCR, ETRMA, TUG, Emisia, HyCentA, Idiada	Dedicated stakeholder meeting for Tasks 1 (Long haul update) and all other aspects of the related major VECTO 2022 update
2022-04-06	Audioweb	DG CLIMA, DG JRC, ACEA, CLEPA, CLCCR, ETRMA, TUG, Idiada	VECTO xEV Workshop #11 (Task 3, how to handle in-motion charging vehicles)
2022-04-29	Audioweb	TF-FCS members	TF-FCS #8
2022-06-07	Audioweb	DG CLIMA, DG JRC, ACEA, CLEPA, CLCCR, TUG, Idiada	Dedicated stakeholder meeting for Tasks 3 (in-motion charging vehicles)
2022-06-10	Audioweb	TF-FCS members	TF-FCS #9
2022-06-22	Audioweb	DG CLIMA, DG JRC, ACEA, CLEPA, EUWA, TUG, Idiada	Dedicated stakeholder meeting for Tasks 4 (Platooning)
2022-07-01	Audioweb	TF-FCS members	TF-FCS #10
2022-07-21	Audioweb	DG JRC, TUG,	Baseline Adjustment

Date	Location	Participants	Topic
2022-09-16	Audioweb	TF-FCS members	TF-FCS #11
2022-09-27	Audioweb	DG CLIMA, DG JRC, ACEA, CLEPA, CLCCR, TUG, Idiada	Dedicated stakeholder meeting for Tasks 3 (in-motion charging vehicles)
2022-10-21	Audioweb	TF-FCS members	TF-FCS #12
2022-10-25	Audioweb	VECTO board members	VECTO board
2022-11-11	Audioweb	DG CLIMA, DG JRC, ACEA, TUG,	Baseline Adjustment
2022-11-25	Audioweb	TF-FCS members	TF-FCS #13
2022-12-13	Audioweb	TF-FCS members	TF-FCS #14 + general H2 topics
2022-12-16	Audioweb	DG CLIMA, DG JRC, Vehicle OEM TUG, Idiada	Platooning
2023-01-13	Audioweb	TF-FCS members	TF-FCS #15 + general H2 topics
2023-01-20	Audioweb	TF-FCS members	TF-FCS #16
2023-03-03	Audioweb	TF-FCS members	TF-FCS #17 + general H2 topics
2023-03-17	Audioweb	TF-FCS members	TF-FCS #18
2023-04-21	Audioweb	TF-FCS members	TF-FCS #19 + general H2 topics
2023-05-26	Audioweb	TF-FCS members	TF-FCS #20 + general H2 topics
2023-06-13	Audioweb	TF-FCS members	TF-FCS #21
2023-07-06	Audioweb	TF-FCS members	TF-FCS #22 + general H2 topics

9 References

- [1] M. Rexeis, M. Röck, M. Quaritsch, S. Hausberger und G. Silberholz, „Further development of VECTO”. Final report for Specific contract No 340201/2018/776882/SER/CLIMA.C.4. By order of EUROPEAN COMMISSION DG CLIMA Report No. I 16/19/Rex EM-I 17/24 5670 from 29.11.2019“.
- [2] M. Rexeis, M. Quaritsch, S. Hausberger und et.al, „VECTO tool development: Completion of methodology to simulate Heavy Duty Vehicles' fuel consumption and CO2 emissions: Upgrades to the existing version of VECTO and completion of certification methodology.“.
- [3] H. Kienzler, M. Drewitz und S. Rikus, „Analysis of a representative driving cycle in European road freight transport,“ Basel, March 2014.
- [4] Hydrogen council, „Hydrogen scaling up,“ Hydrogen council, 2017.
- [5] H. E. A. T. M. Klell, „Wasserstoff in der Fahrzeugtechnik,“ Springer Verlag, 2018.
- [6] M. B. T. Z. A. M. a. J. R. Y. Ruf, „Fuel Cells Hydrogen Trucks, Heavy-Duty's High Performance Green Solution,“ Brussels, 2020.
- [7] California Environmental Protection Agency, „Draft technology assessment: medium- and heavy-duty fuel cell electric vehicles,“ 2015.
- [8] J. Marcinkoski, „Technical Targets for Hydrogen-Fueled Long-Haul Tractor-Trailer Trucks,“ 12 December 2019. [Online]. Available: https://www.hydrogen.energy.gov/pdfs/19006_hydrogen_class8_long_haul_truck_targets.pdf. [Zugriff am 12 June 2021].
- [9] GreenCarCongress, „Stellantis developing hydrogen fuel cell light commercial vehicle; partnership with Faurecia and Symbio,“ 6 April 2021. [Online]. Available: <https://www.greencarcongress.com/2021/04/20210406-stellantis.html>. [Zugriff am 23 June 2021].
- [10] Plug Power, Inc., „HYVIA: Renault Group and Plug Power's Joint Venture Leads the Way to a Complete Ecosystem of Fuel Cell Powered LCVs, Green Hydrogen and Refueling Stations Across Europe,“ 6 March 2021. [Online]. Available: <https://www.ir.plugpower.com/Press-Releases/Press-Release-Details/2021/HYVIA-Renault-Group-and-Plug-Powers-Joint-Venture--Leads-the-Way-to-a-Complete-Ecosystem-of-Fuel-Cell-Powered-LCVs-Green->. [Zugriff am 23 June 2021].
- [11] Opel, „Opel Vivaro-e HYDROGEN: Plug-In Fuel Cell Electric Vehicle Offers Zero Emissions and Quick Refuelling,“ 17 May 2021. [Online]. Available: <https://int-media.opel.com/en/05-17-opel-vivaro-e-hydrogen#prettyPhoto>. [Zugriff am 23 June 2021].
- [12] Renault, „RENAULT RUNS ON HYDROGEN WITH MASTER Z.E. HYDROGEN AND KANGOO Z.E. HYDROGEN,“ 2019. [Online]. Available: <https://en.media.groupe.renault.com/assets/2019-press-kit-groupe-renault-introduces-hydrogen-into-its-light-commercial-vehicles-range-press-kit-e043-989c5.html?dl=1>. [Zugriff am 23 June 2021].
- [13] Moditech, „Hyundai FC truck added,“ [Online]. Available: <https://www.moditech.com/news/hyundai-brings-xcient-fuel-cell-truck-to-european-truck-market/>. [Zugriff am 23 June 2021].

- [14] Daimler Truck, „World Premiere: The Mercedes-Benz GenH2 Truck with Sven Ennerst,“ 16 September 2020. [Online]. Available: <https://media.daimlertruck.com/marsMediaSite/en/instance/ko/Videos.xhtml?oid=47382840#prevId=47465634>. [Zugriff am 23 June 2021].
- [15] Bosch Mobility Solutions, „eDistanceTruck,“ 2020. [Online]. Available: https://www.bosch-mobility.com/media/global/products-and-services/commercial-vehicles/powertrain-solutions/edistancetruck-electric-drive-solutions/summary_edistance_truck_en_rgb_150dpi_20201112.pdf. [Zugriff am 23 June 2021].
- [16] FlixBus, „FlixBus Plans First European Long-Distance Buses with Fuel Cell Power,“ 2 September 2019. [Online]. Available: <https://corporate.flixbus.com/flixbus-plans-first-european-long-distance-buses-with-fuel-cell-power/>. [Zugriff am 7 June 2021].
- [17] Freudenberg Sealing Technologies, „Fuel Cells for Long-Distance Bus Transport,“ 2 September 2019. [Online]. Available: <https://www.fst.com/corporate/newsroom/press-releases/2019/freudenberg-flixbus-press/>. [Zugriff am 7 June 2021].
- [18] Solaris, „Solaris Customer Magazine,“ Solaris, Spring 2019.
- [19] GreenCarCongress, „DOE: 1 fuel cell bus in US has exceeded the DOE/DOT target of 25,000 hours; more getting close,“ 6 April 2021. [Online]. Available: <https://www.greencarcongress.com/2019/01/20190125-fceb.html>. [Zugriff am 23 June 2021].
- [20] K. Lee, „Hyundai Motor begins to export hydrogen electric vehicles to Saudi Arabia,“ The Korea Post, 5 October 2020. [Online]. Available: <http://www.koreapost.com/news/articleView.html?idxno=21572>. [Zugriff am 23 June 2021].
- [21] CORDIS Europa, „Joint Initiative for hydrogen Vehicles across Europe 2,“ 26 January 2021. [Online]. Available: <https://cordis.europa.eu/project/id/779563>. [Zugriff am 23 June 2021].
- [22] Sustainable-Bus, „Wrightbus unveiled the first fuel cell double decker in the world,“ 19 November 2018. [Online]. Available: <https://www.sustainable-bus.com/fuel-cell-bus/streetdeck-fcev-wrightbus-first-fuel-cell-double-decker-bus-in-the-world/>. [Zugriff am 23 June 2021].
- [23] T. Malkow, A. Saturnio, A. Pilenga, G. d. Marco, M. Honselaar und G. Tsotridis, „Assessment of PEFC performance by applying harmonized testing procedure.,“ *International Journal of Energy Research*, Bd. 35, Nr. 12, p. 1075–1089, 2011.
- [24] F. R. Hussein Basma, „Fuel cell electric tractor-trailers,“ 2022.
- [25] S. C. S. T. D.-D. E. B. M. W. ., S. & H. O. Pardhi, „A Review of Fuel Cell Powertrains for Long-Haul Heavy-Duty Vehicles: Technology, Hydrogen, Energy and Thermal Management Solutions,“ *Recent Power Electronics and Control Systems For (Plug-In) Electric (Hybrid) Vehicles (Volume II)*, pp. Volume 15, Issue 24, 16 December 2022.
- [26] E. Barsoukov und J. (. Macdonald, *Impedance Spectroscopy: Theory, Experiment, and Applications*, 2nd Edition, Wiley, 2005.
- [27] R. e. a. Carter, „Membrane electrode assemblies (MEAs) degradation mechanisms studies by current distribution measurements,“ *Handbook of Fuel Cells - Fundamentals, Technology and Applications*, p. pp. 829, 2009.

- [28] P. Kurzweil, Brennstoffzellentechnik 2. Auflage, Wiesbaden: Vieweg Verlag, 2012.
- [29] J. e. a. Zhang, „FC Catalyst Degradation Review,“ *Encyclopedia of Electrochemical Power Sources (Ed.: J. Garche) vol. 2*, p. pp. 626, 2009.
- [30] J. e. a. Zhang, „Recoverable Performance Loss Due to Membrane Chemical Degradation in PEM Fuel Cells,“ *J. Electrochem. Soc. vol. 159*, pp. F287-F293, 2012.
- [31] D. Bezmalinovic, B. Simic und F. Barbir, „Characterization of PEM fuel cell degradation by polarization change curves,“ *Journal of Power Sources, Volume 294*, pp. 82-87, 2015.
- [32] A. R. E. L. S. G. J. B. A.-M. N. P. T. M. J. Hua T, „Status of hydrogen fuel cell electric buses worldwide,“ *Journal of Power Sources vol. 296*, pp. 975-993, 2014.
- [33] J. D. T. M. Camacho M, „Hydrogen fuel cell heavy-duty trucks: Review of main research topics,“ *Int. Journal of Hydrogen Energy vol. 47*, pp. 29505-29525, 2022.
- [34] W. T. R. M. O. A. Baroutaji A, „Comprehensive investigation on hydrogen and fuel cell technology in the aviation and aerospace sectors,“ *Renewable and Sustainable Energy Reviews vol. 106*, pp. 31-40, 2019.
- [35] C. H. G. H. Y. F. L. J. Song WJ, „Research progress of proton exchange membrane fuel cells utilizing in high altitude environments,“ *International Journal of Hydrogen Energy vol. 47 issue 59*, pp. 24945-24962, 2022.
- [36] P. P. T. A. Wallnöfer-Ogris E, „Quasi-stationary UI-characteristic model of a PEM fuel cell–Evaluating the option of self-humidifying operation,“ *International Journal of Hydrogen Energy vol. 45 issue 56*, pp. 32464-32477, 2020.
- [37] G. M. Y. A. V. H. J. Pourrahmani H, „Optimization and dynamic responses of an integrated fuel cell and battery system for an 800 kW ferry: A case study,“ *Energy Reports vol. 8*, pp. 9757-9776, 2022.
- [38] F. P. R. K. M.-G. M. A. T. Eva Wallnöfer-Ogris, „Main degradation mechanisms of polymer electrolyte membrane fuel cell stacks – Mechanisms, influencing factors, consequences, and mitigation strategies,“ *International Journal of Hydrogen Energy*, p. Online, 2023.
- [39] E. H. T. A. Klell M, *Hydrogen in Automotive Engineering: Production, Storage, Application*, Wiesbaden: Springer, 2022.
- [40] e. Jason Marcinkoski, „DOE Advanced Truck Technologies Subsection of the Electrified Powertrain Roadmap Technical Targets for Hydrogen-Fueled Long-Haul Tractor-Trailer Trucks,“ 2019. [Online]. Available: https://www.hydrogen.energy.gov/pdfs/19006_hydrogen_class8_long_haul_truck_targets.pdf. [Zugriff am 12 June 2021].
- [41] H. Dale und L. Nic, „Estimating the infrastructure needs and costs for the launch of zero-emission trucks,“ ICCT (The International Commission on Clean Transportation), 2019.
- [42] M. F. Far, M. Paakinen und P. Cremers, „A Framework for Charging Standardisation of Electric Buses in Europe,“ in *IEEE Vehicle Power and Propulsion Conference (VPPC)*, Gijon, Spain, 2020.
- [43] „eHighway – Solutions for electrified road freight transport,“ Siemens, 08 November 2017. [Online]. Available: <https://press.siemens.com/global/en/feature/ehighway-solutions-electrified-road-freight-transport>. [Zugriff am 07 04 2022].

- [44] I. Mareev und D. U. Sauer, „Energy Consumption and Life Cycle Costs of Overhead Catenary Heavy-Duty Trucks for Long-Haul Transportation,“ *Energies MDPI*, Bde. %1 von %211(12), 3446, 2018.
- [45] WAVE IPT, „A Future of Electric Vehicles with Unlimited Range - Wave,“ 22 June 2020. [Online]. Available: <https://waveipt.com/wave-provides-a-glimpse-into-a-visionary-future-of-electric-vehicles-with-unlimited-range/>.
- [46] „European Alternative Fuel Observatory,“ European commission Mobility and Transport, [Online]. Available: <https://www.eafo.eu/alternative-fuels/electricity/charging-infra-stats>. [Zugriff am 9 March 2021].
- [47] „Proposal for an Electric Vehicle Regulatory Reference Guide (ECE /TRANS/WP.29/2014/81),“ UNECE, 2014.
- [48] „IEC - TC 69 Dashboard> Scope,“ International Electrotechnical Commission, [Online]. Available: https://www.iec.ch/dyn/www/f?p=103:7:0:::FSP_ORG_ID,FSP_LANG_ID:1255,25. [Zugriff am 10 05 2021].
- [49] „IEC - TC 9 Dashboard> Scope,“ International Electrotechnical Commission, [Online]. Available: https://www.iec.ch/dyn/www/f?p=103:7:7741098544602:::FSP_ORG_ID,FSP_LANG_ID:1248,25. [Zugriff am 10 05 2021].
- [50] „IEC 62486:2017 | IEC Webstore,“ International Electrotechnical Commission, [Online]. Available: <https://webstore.iec.ch/publication/32091>. [Zugriff am 10 05 2021].
- [51] „Electric Vehicle Power Transfer System Using Conductive Automated Connection Devices,“ SAE, 20 01 2020. [Online]. Available: https://www.sae.org/standards/content/j3105_202001/.
- [52] J. Shuttleworth, „SAE news,“ SAE, [Online]. Available: <https://www.sae.org/news/2020/02/sae-j3105-promotes-safe-charging-for-buses-and-heavy-duty-vehicles>. [Zugriff am 09 March 2021].
- [53] „V2G-Clarity,“ 25 Feb 2019. [Online]. Available: <https://v2g-clarity.com/knowledgebase/what-is-iso-15118/>. [Zugriff am 10 May 2021].
- [54] „Agreement for future standard collaboration signed,“ CHAdeMO Association, 28 08 2018. [Online]. Available: <https://www.chademo.com/chademo-association-and-the-china-electricity-council-agreement-for-future-standard-collaboration-signed/>. [Zugriff am 11 03 2021].
- [55] N. Feng und T. IMAZU, „ChaoJi - A Unified Future-Oriented Charging Programme,“ State Grid Corporation of China and CHAdeMO association, 2020.
- [56] „Alstom presents SRS ground based recharging systems for electric buses,“ [Online]. Available: www.alstom.com/press_release_news/2019/9/alstom-presents-srs-ground-based-recharging-system-electric-buses.
- [57] „Schunk Smart Charging Underbody charger,“ [Online]. Available: <https://www.schunk-carbontechnology.com/nl/products/prosukte-detail/schunk-smart-charging-underbody-charger>.
- [58] M. Gustavsson, F. Hacker und H. Helms, „Overview of ERS concepts and complementary technologies,“ RISE Research Institutes of Sweden, 2019.
- [59] Siemens Mobility, [Online]. Available: <https://press.siemens.com/global/en/feature/ehighway-solutions-electrified-road-freight-transport>. [Zugriff am 25 04 2022].

- [60] „The world’s first electric highway,“ Sandviken, [Online]. Available: <https://sandvikenpurepower.com/english/electric-highway.html>. [Zugriff am 25 04 2022].
- [61] p. EMOBICITY, „Project ELISA – electrified, innovative heavy traffic on highways,“ 18 02 2020. [Online]. Available: <https://ehighway.eu.hessen.de/>. [Zugriff am 12 04 2022].
- [62] S. A. Dr. Michael Lehmann, „Construction of a 1 Mile Catenary System and Develop & Demonstrate Catenary Electric Trucks,“ SCAQMD Contract 14062, SIEMENS AG, Carson, CA and Erlangen, Germany, 2018.
- [63] „FESH – eHighway field test on the A1 motorway in Schleswig-Holstein,“ [Online]. Available: <https://www.ehighway-sh.de/>. [Zugriff am 12 04 2022].
- [64] „Was ist eWayBW?,“ [Online]. Available: <https://ewaybw.de/en/ewaybw/>. [Zugriff am 12 04 2022].
- [65] V. S. ICT, „Slide-in Electric Road System, Conductive project report,“ Volvo GTT, Gothenburg, 2013.
- [66] „ELONROAD,“ Elonroad, [Online]. Available: <https://elonroad.com/story/#story>.
- [67] U. T. Committee, „HOW TO BUILD AND OPERATE AN EFFICIENT TROLLEYBUS SYSTEM,“ International Association of Public Transport, 2015, 2015.
- [68] S. Ahn, N. P. Suh und D.-h. Cho, „Charging up the road,“ *IEEE Spectrum*, pp. 49-54, April 2013.
- [69] „Fabric-project,“ [Online]. Available: <http://www.fabric-project.eu/www.fabric-project.eu/index.html>. [Zugriff am 16 03 2021].
- [70] „WAVE IPT,“ Wireless Advanced Vehicle Electrification, Inc. , [Online]. Available: <https://waveipt.com/>. [Zugriff am 16 03 2021].
- [71] „Electreon,“ Electreon, [Online]. Available: <https://www.electreon.com/>. [Zugriff am 16 03 2021].
- [72] D. Dujčić, „Electric Vehicles Charging - An ultrafast overview,“ PCIM Europe, 2018.
- [73] M. Kosowski, „Transit Bus Fleet Size,“ Electric Power Research Institute, New York, 2019.
- [74] „ABB factsheet - TOSA – Enabling a new generation of electric buses,“ [Online]. Available: https://library.e.abb.com/public/ba41f281771a41e3a1da537b42842729/ABB_factsheetA4_TOSA_technology_EN.pdf. [Zugriff am 06 05 2022].
- [75] T. Bohn, „Multi-port, 1+MW Charging System for Medium- and Heavy-Duty EVs: What We Know and What Is on the Horizon?,“ Argonne National Laboratory, 2020.
- [76] R. Kocher, „High Power Commercial Vehicle Charging Standardization Task Force update,“ CharIN, 2019.
- [77] R. M. Q. M. P. S. Silberholz G., „VECTO: Extension to hybrids and further technical support,“ Graz, 2022.
- [78] T. L. (TRL), „ELECTRIC ROAD SYSTEMS: A SOLUTION FOR THE FUTURE,“ World Road Association (PIARC), 2018.

- [79] S. AG, „ENUBA 2 - Elektromobilität bei schweren Nutzfahrzeugen zur Umweltentlastung von Ballungsräumen,“ Bundesministeriums für Umwelt, Naturschutz, Bau und Reaktorsicherheit (BMUB), 2016.
- [80] „Trolleybus fact and fiction,“ Transport Action British Columbia , [Online]. Available: http://bc.transportaction.ca/wp-content/uploads/learning/etb/trolley_alert.html. [Zugriff am 2021].
- [81] SIEMENS, „Vehicle – Pantograph Evaluation of Aerodynamics White Paper,“ 2021.
- [82] SARTRE, „SARTRE,“ [Online]. Available: <https://cordis.europa.eu/project/id/233683/reporting>.
- [83] COMPANION, „COMPANION,“ [Online]. Available: <https://cordis.europa.eu/project/id/610990/reporting>.
- [84] ENSEMBLE, „<https://platooningensemble.eu/>,“ [Online].
- [85] „AEROFLEX,“ [Online]. Available: <https://aeroflex-project.eu/>.
- [86] „HFAUTO,“ [Online]. Available: <https://cordis.europa.eu/project/id/605817/reporting>.
- [87] „ROADART,“ [Online]. Available: <http://www.roadart.eu/>.
- [88] „Connecting Austria,“ [Online]. Available: <http://www.connecting-austria.at>.
- [89] H. C. S. W. e. a. Tran C., „EDDI - Electronic Drawbar - Digital Innovation,“ MAN Truck & Bus SE, München, 2019.
- [90] TRL, „Helm UK - Final Report,“ United Kingdom, 2022.
- [91] „UNECE WP29,“ [Online]. Available: <https://unece.org/wp29-introduction>. [Zugriff am September. 2021].
- [92] J. P. Sergi Urpi, „D7.4 – Consolidated validation results of the COMPANION,“ Applus+ IDIADA, 2016.
- [93] E.-M. A. François Combes, „Analysis of market needs, business models and life-cycle,“ ENSEMBLE Project, Univ Gustave Eiffel, France, 2022.
- [94] M. P. S. Jootel, „SAfe Road TRains for the Environment - Project Final Report,“ 2012.
- [95] Synopsys, „<https://www.synopsys.com/verification/virtual-prototyping/virtual-ecu/fmu-sdk.html>,“ [Online].
- [96] Qtronic, „<https://github.com/qtronic/fmusdk>,“ [Online].
- [97] Modelon, „<https://www.modelon.com/products-services/modelon-deployment-suite/fmi-toolbox/>,“ [Online].
- [98] powersys-solution, „<https://powersys-solutions.com/product/?software=Easy%20FMI%20Add-On%20for%20MATLAB/Simulink>,“ [Online].
- [99] C. Systems, „<https://github.com/CATIA-Systems/FMIKit-Simulink>,“ [Online].
- [10] FmiWrapper, „<https://github.com/Tuebel/FmiWrapper/>,“ [Online].
- [10] M. A. C. N. H. S. F. B. M. K. William Resende, „Fuel cells for commercial vehicles - Challenges and solutions,“ in *Sustainable Mobility, Transport and Power Generation*, Graz (Austria), 2021.

- [10 R. Luz, M. Rexeis, L. Schulte, J. Hammer, H. Steven, Verbeek und et.al, „Development and validation
2] of a methodology for monitoring and certification of greenhouse gas emissions from heavy duty vehicles through vehicle simulation, Final report; Service contract CLIMA.C.2/SER/2012/0004; Report No. I 07/14/Rex EM-I 2012/08 699 f“.
- [10 H2 Mobility, „Overview Hydrogen Refuelling For Heavy Duty Vehicles,“ H2 MOBILITY Deutschland
3] GmbH & Co. KG, Berlin, Germany, 2021.